

## MINIMUM SECURITY DOUBLE DEFLECTION SUPPLY GRILLES AND REGISTERS

- LATTICE FACE
- LOUVERED BLADES

### Models:

**SG-61DV and DH Steel**  
**SG-51DV and DH Aluminum**

- Suffix '-O' adds an opposed blade damper

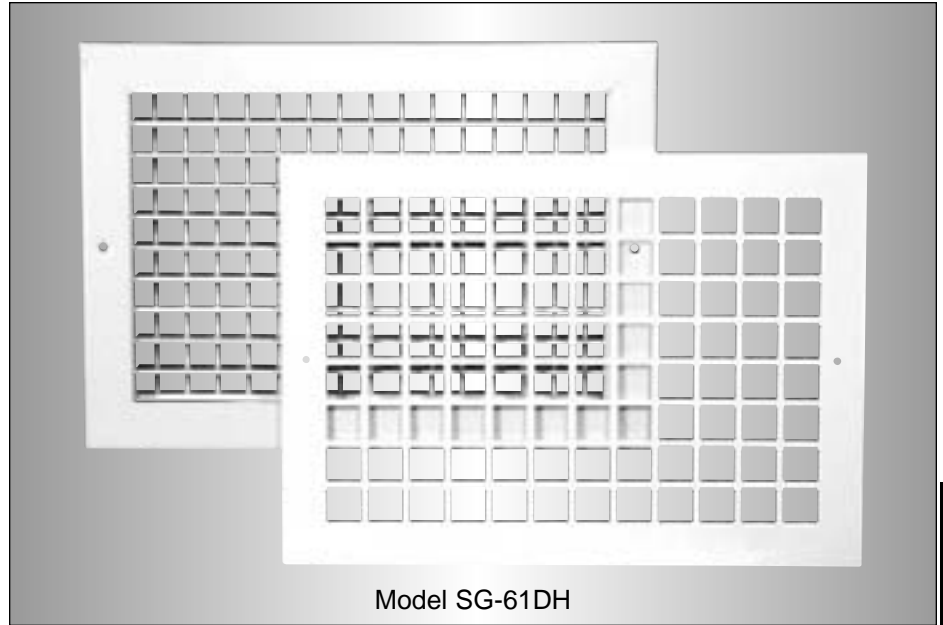

These models are suitable for minimum security applications where the location is either hard to reach, such as high walls or ceilings in day rooms, or where there is constant supervision. The actual size of the unit may have a bearing on its application if the grille size selected is small enough that physical removal and/or bodily entry would not be contemplated. These models are essentially the same as the corresponding **Nailor 6100** and **5100 Series** range of grilles with the addition of a lattice face for additional security.

### FEATURES:

- Lattice Face: 12 gauge steel or aluminum with 13/16" (21) square holes on 1" (25) centers. 3/16" (5) fret bars. Other lattice configurations are available.
- Grille or register is same as corresponding **6100** or **5100 Series**.
- Blades on 3/4" (19) centers are individually adjustable.
- Front blades are vertical (V) or horizontal (H) with the rear blades having the opposite orientation.
- Standard finish is AW Appliance White. Other finishes are available.
- Screw holes provided in face plate. Tamper proof/security screws by others to suit local requirements.
- Performance Data: See the appropriate base model and add the pressure drop of lattice face from table on page H22.
- Available in sizes 6" x 4" (152 x 102) through 48" x 24" (1219 x 610) in one piece construction.

### Options:

- Opposed blade damper (steel or aluminum) has a screwdriver slot operator accessible through face of register.

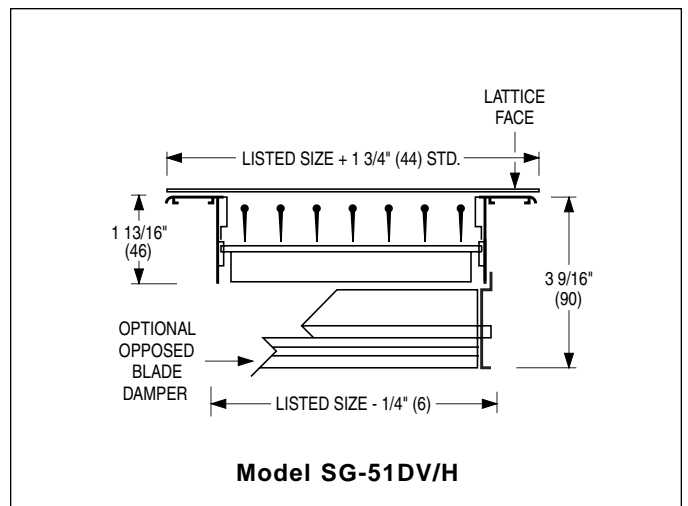
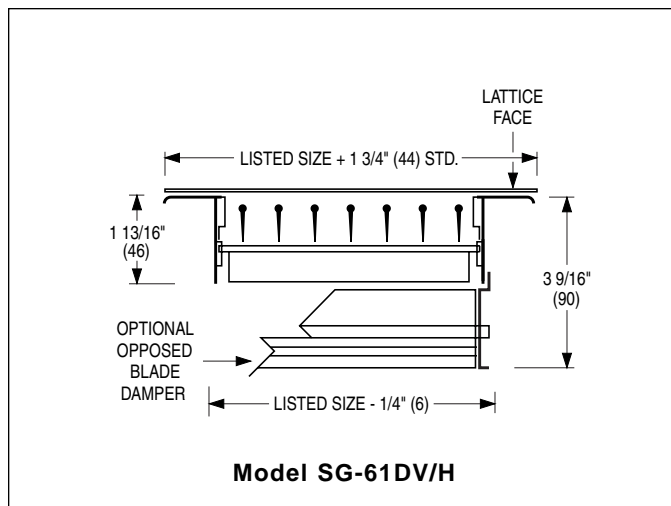

## MINIMUM SECURITY SINGLE DEFLECTION SUPPLY GRILLES AND REGISTERS

- LATTICE FACE
- LOUVERED BLADES

### Models:

**SG-61SV and SH Steel**  
**SG-51SV and SH Aluminum**

- Suffix '-O' adds an opposed blade damper

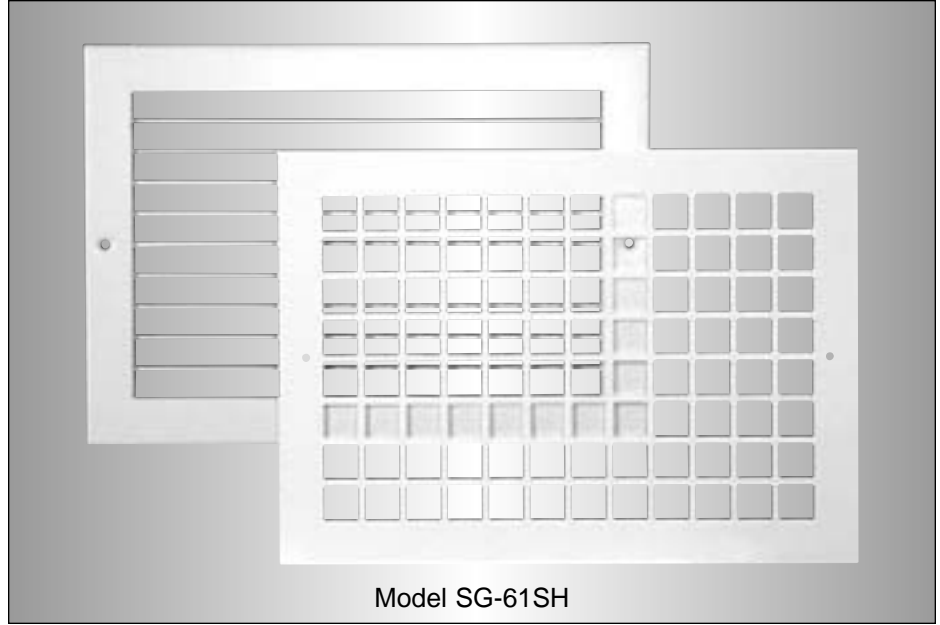

These models are suitable for minimum security applications where the location is either hard to reach, such as high walls or ceilings in day rooms, or where there is constant supervision. The actual size of the unit may have a bearing on its application if the grille size selected is small enough that physical removal and/or bodily entry would not be contemplated. These models are essentially the same as the corresponding **Nailor 6100** and **5100 Series** range of grilles with the addition of a lattice face for additional security.

### FEATURES:

- Lattice Face: 12 gauge steel or aluminum with 13/16" (21) square holes on 1" (25) centers. 3/16" (5) fret bars. Other lattice configurations are available.
- Grille or register is same as corresponding **6100** or **5100 Series**.
- Blades on 3/4" (19) centers are individually adjustable.
- Available with vertical (V) or horizontal (H) blades.
- Standard finish is AW Appliance White. Other finishes are available.
- Screw holes provided in face plate. Tamper proof/security screws by others to suit local requirements.
- Performance Data: See the appropriate base model and add the pressure drop of lattice face from table on page H22.
- Available in sizes 6" x 4" (152 x 102) through 48" x 24" (1219 x 610) in one piece construction.

### Options:

- Opposed blade damper (steel or aluminum) has a screwdriver slot operator accessible through face of register.

