

LINEAR SLOT DIFFUSERS

- ALUMINUM CONSTRUCTION
- 'ICE TONG' PATTERN CONTROLLERS

Supply Models:

- 5050 1/2" (13) Slot
- 5075 3/4" (19) Slot
- 5010 1" (25) Slot

Return Models:

- 5050R 1/2" (13) Slot
- 5075R 3/4" (19) Slot
- 5010R 1" (25) Slot

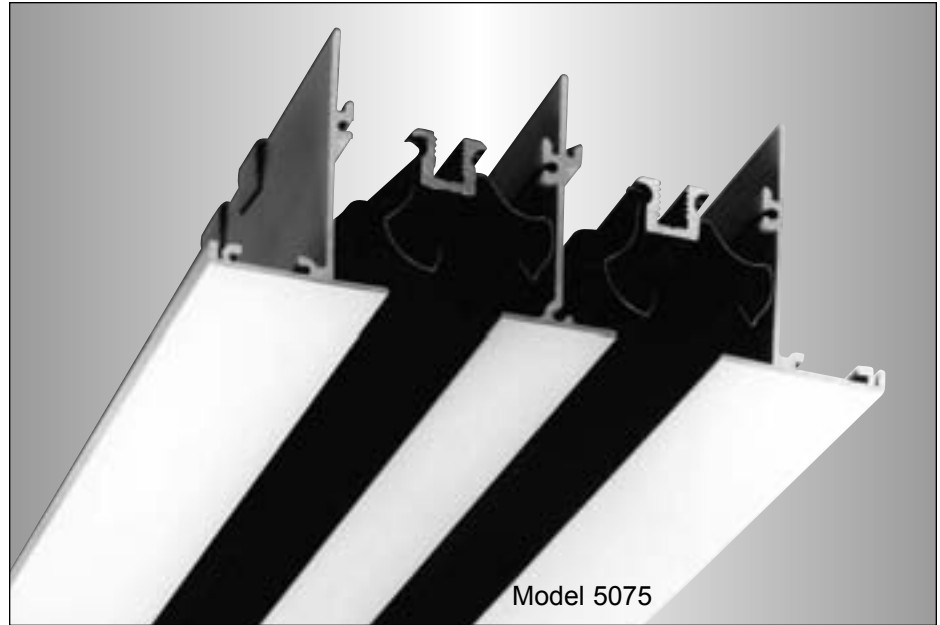

The **Series 5000 Linear Slot Ceiling Diffuser** has been specially designed to provide both the unobtrusive appearance required for architectural excellence, and the full 180° pattern controller adjustment at minimum NC levels required for high engineering performance.

The **Series 5000 Diffuser** provides stable diffusion under large amounts of air with both constant and changing load conditions. This is particularly suitable for variable air volume systems.

The **Series 5000 Diffusers** are available to suit many applications with several choices of mounting frames. Standard finish is a high quality, hard baked enamel for long life and easy cleaning.

The diffusers are available with mitered corner end caps and feature die-formed components to provide consistent quality and performance.

FEATURES:

- The volume and direction of the discharge air can be adjusted by moving the pattern controllers.
- Available with 1 to 10 slots.
- Choice of three slot widths to suit capacity requirements.
- The maximum length of the pattern controller is 36" (914). Diffusers longer than 36" (914) are provided with multiple pattern controller sections.
- Selection of frames and mounting sub-frames for various types of installations.
- Diffusers are supplied in lengths of up to 6 feet (1829) in a single section.
- Ideal for continuous length applications.
- Multiple sections are provided with alignment strips on the frames and sub-frames to provide superior, positive field alignment.
- **Model 5000R** returns and the **Model 5000** supply diffusers are identical except for the omission of pattern controllers.
- Mounting sub-frames are cut to length and assembled in the field.

Material: Extruded aluminum frame with corrosion-resistant steel pattern controllers.

Finish: AW Appliance White baked enamel frame with black pattern controllers is standard. Other finishes are available.

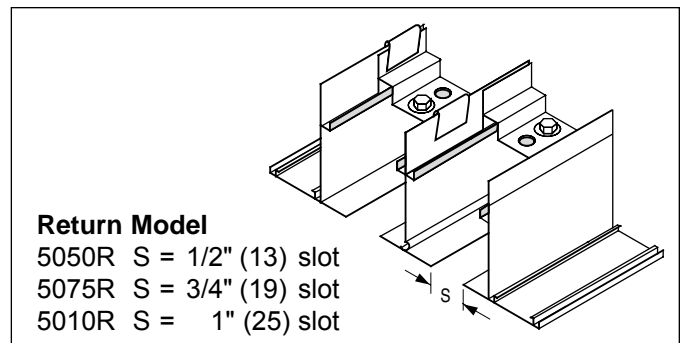
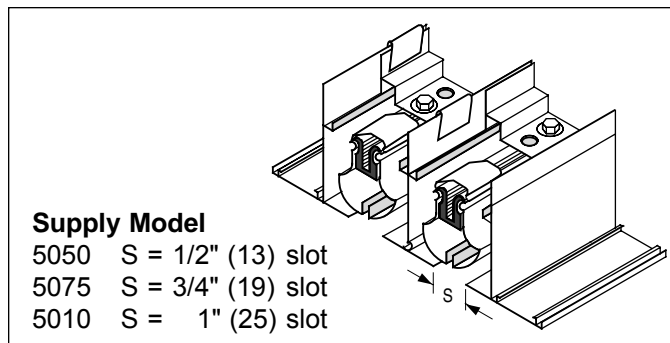

Various types of frame and mounting sub-frame combinations for hard ceilings.

D = Duct Size

S = Slot Width

W = Overall Face Width

Standard Frames are the most commonly specified and readily available from stock.

Dimensions are in inches (mm).

Standard Frame

Type A

- Flange Frame
- Screw Mounting

Type B

- Flange Frame
- Duct Mounting, less screw holes

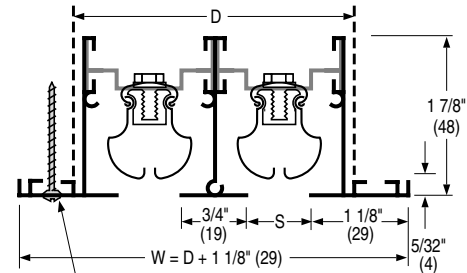

COUNTERSUNK SCREW HOLES FOR #8 SCREWS, 3/8" (10) FROM EDGE

Standard Frame

Type C

- Flange Frame
- Concealed Mounting

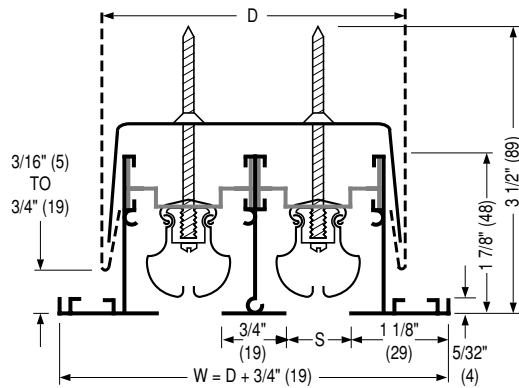

Standard Frame

Type D

- Flange Frame, Narrow Margin
- Concealed Mounting

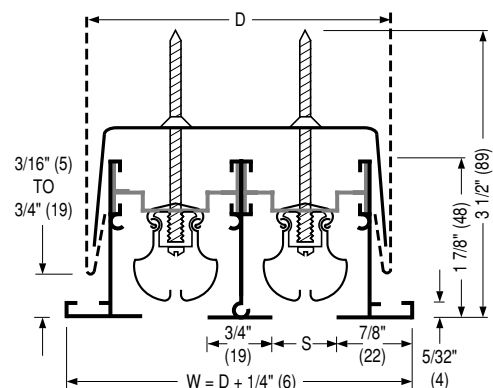

Type E

- Flush Frame and Sub-Frame
- Concealed Mounting

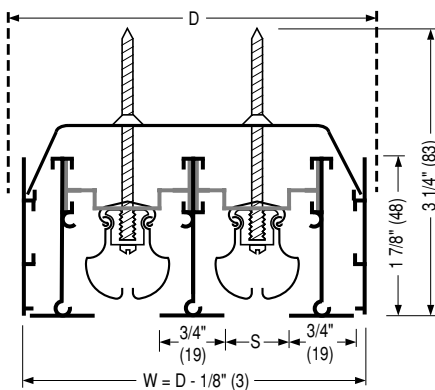

Type F

- Flange Frame and Sub-Frame
- Concealed Mounting

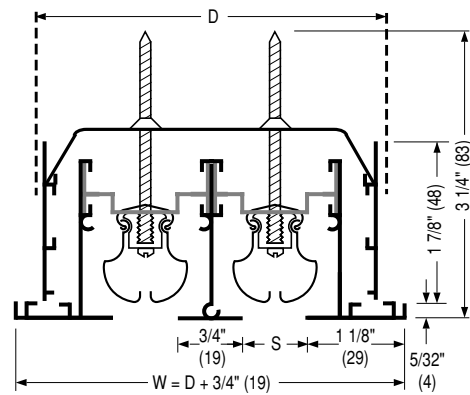

Type G

- Flush Frame with Plaster and Tile Sub-Frame
- Concealed Mounting

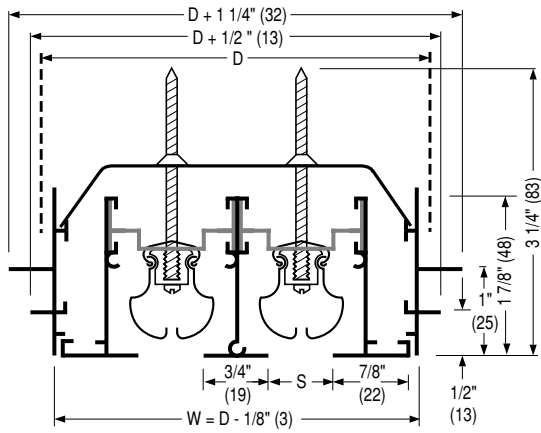

Type H

- Flange Frame with Plaster and Tile Sub-Frame
- Concealed Mounting

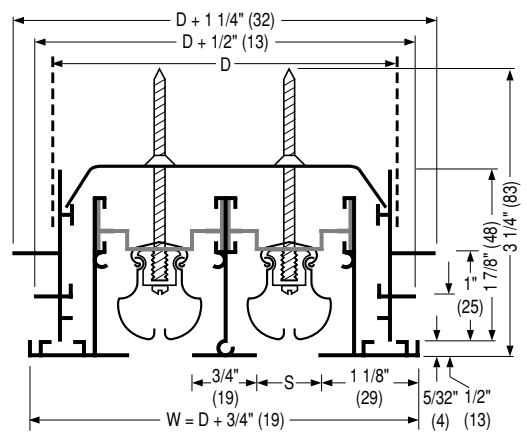

Type M

- Flush Frame
- Duct Mounting
- Flangeless Frame

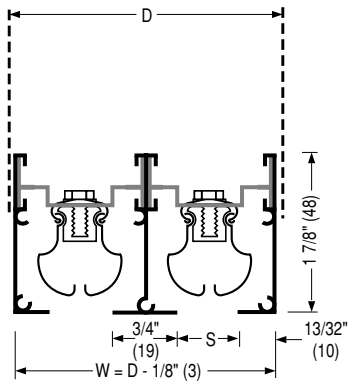

Type N

- Spline Frame Ceiling
- Concealed Mounting

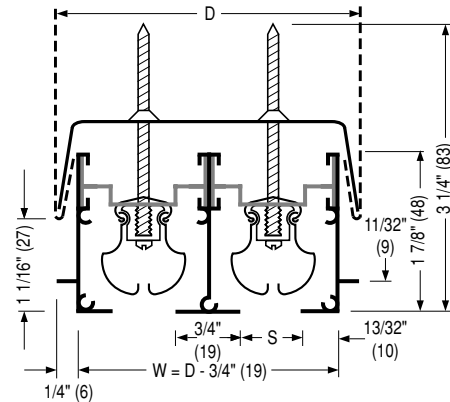

Alignment Strips

Alignment strips on the frames and sub-frames provide superior, positive alignment on multiple section assemblies.

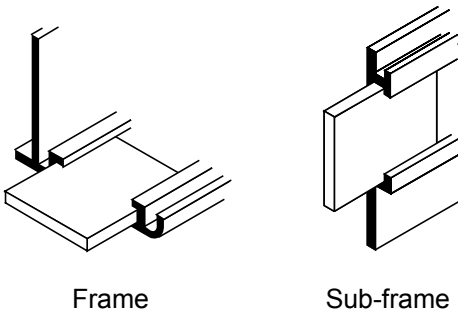

Consult page B10 for Type T Lay-in T-Bar and Type FL Finline® Frame.

For the availability of other frames and supporting methods, contact your Nailor representative for assistance.

For duct dimensions D see next page.

Dimensions are in inches (mm).

Duct Width D Dimension for Available Frames

Imperial Units (inches)

Frame Type	No. of Slots	5050	5075	5010
		5050R S=1/2	5075R S=3/4	5010R S=1
A B	1	1 5/8	1 7/8	2 1/8
	2	2 7/8	3 3/8	3 7/8
	3	4 1/8	4 7/8	5 5/8
	4	5 3/8	6 3/8	7 3/8
	5	6 5/8	7 7/8	9 1/8
	6	7 7/8	9 3/8	10 7/8
	7	9 1/8	10 7/8	12 5/8
	8	10 3/8	12 3/8	14 3/8
	9	11 5/8	13 7/8	16 1/8
	10	12 7/8	15 3/8	17 7/8

Frame Type	No. of Slots	5050	5075	5010
		5050R S=1/2	5075R S=3/4	5010R S=1
C D	1	2	2 1/4	2 1/2
	2	3 1/4	3 3/4	4 1/4
	3	4 1/2	5 1/4	6
	4	5 3/4	6 3/4	7 3/4
	5	7	8 1/4	9 1/2
	6	8 1/4	9 3/4	11 1/4
	7	9 1/2	11 1/4	13
	8	10 3/4	12 3/4	14 3/4
	9	12	14 1/4	16 1/2
	10	13 1/4	15 3/4	18 1/4

Frame Type	No. of Slots	5050	5075	5010
		5050R S=1/2	5075R S=3/4	5010R S=1
E	1	2 1/4	2 1/2	2 3/4
	2	3 1/2	4	4 1/2
	3	4 3/4	5 1/2	6 1/4
	4	6	7	8
	5	7 1/4	8 1/2	9 3/4
	6	8 1/2	10	11 1/2
	7	9 3/4	11 1/2	13 1/4
	8	11	13	15
	9	12 1/4	14 1/2	16 3/4
	10	13 1/2	16	18 1/2

Frame Type	No. of Slots	5050	5075	5010
		5050R S=1/2	5075R S=3/4	5010R S=1
F H N	1	2	2 1/4	2 1/2
	2	3 1/4	3 3/4	4 1/4
	3	4 1/2	5 1/4	6
	4	5 3/4	6 3/4	7 3/4
	5	7	8 1/4	9 1/2
	6	8 1/4	9 3/4	11 1/4
	7	9 1/2	11 1/4	13
	8	10 3/4	12 3/4	14 3/4
	9	12	14 1/4	16 1/2
	10	13 1/4	15 3/4	18 1/4

Frame Type	No. of Slots	5050	5075	5010
		5050R S=1/2	5075R S=3/4	5010R S=1
G	1	2 1/2	2 3/4	3
	2	3 3/4	4 1/4	4 3/4
	3	5	5 3/4	6 1/2
	4	6 1/4	7 1/4	8 1/4
	5	7 1/2	8 3/4	10
	6	8 3/4	10 1/4	11 3/4
	7	10	11 3/4	13 1/2
	8	11 1/4	13 1/4	15 1/4
	9	12 1/2	14 3/4	17
	10	13 3/4	16 1/4	18 3/4

Frame Type	No. of Slots	5050	5075	5010
		5050R S=1/2	5075R S=3/4	5010R S=1
M	1	1 3/8	1 5/8	1 7/8
	2	2 5/8	3 1/8	3 5/8
	3	3 7/8	4 5/8	5 3/8
	4	5 1/8	6 1/8	7 1/8
	5	6 3/8	7 5/8	8 7/8
	6	7 5/8	9 1/8	10 5/8
	7	8 7/8	10 5/8	12 3/8
	8	10 1/8	12 1/8	14 1/8
	9	11 3/8	13 5/8	15 7/8
	10	12 5/8	15 1/8	17 5/8

Metric Units (mm)

Frame Type	No. of Slots	5050	5075	5010
		5050R S=13	5075R S=19	5010R S=25
A B	1	41	48	54
	2	73	86	98
	3	105	124	143
	4	137	162	187
	5	168	200	232
	6	200	238	276
	7	232	276	321
	8	264	314	365
	9	295	352	410
	10	327	391	454

Frame Type	No. of Slots	5050	5075	5010
		5050R S=13	5075R S=19	5010R S=25
C D	1	51	57	64
	2	83	95	108
	3	114	133	152
	4	146	171	197
	5	178	210	241
	6	210	248	286
	7	241	286	330
	8	273	324	375
	9	305	362	419
	10	337	400	464

Frame Type	No. of Slots	5050	5075	5010
		5050R S=13	5075R S=19	5010R S=25
E	1	57	64	70
	2	89	102	115
	3	121	140	159
	4	152	178	203
	5	184	216	248
	6	216	254	292
	7	248	292	337
	8	279	330	381
	9	312	368	425
	10	343	406	470

Frame Type	No. of Slots	5050	5075	5010
		5050R S=13	5075R S=19	5010R S=25
F H N	1	51	57	64
	2	83	95	108
	3	115	133	152
	4	146	171	197
	5	178	210	241
	6	210	248	286
	7	241	286	330
	8	273	324	375
	9	304	362	419
	10	337	400	464

Frame Type	No. of Slots	5050	5075	5010
		5050R S=13	5075R S=19	5010R S=25
G	1	64	70	76
	2	95	108	121
	3	127	146	165
	4	159	184	210
	5	191	222	254
	6	222	260	298
	7	254	298	343
	8	286	337	387
	9	318	375	432
	10	349	413	476

Frame Type	No. of Slots	5050	5075	5010
		5050R S=13	5075R S=19	5010R S=25
M	1	35	41	48
	2	67	79	92
	3	98	117	137
	4	130	156	181
	5	162	194	225
	6	194	232	270
	7	225	270	314
	8	257	308	359
	9	289	346	400
	10	321	384	448

B LINEAR DIFFUSERS AND BAR GRILLES

End Cap Configurations for Various Mountings

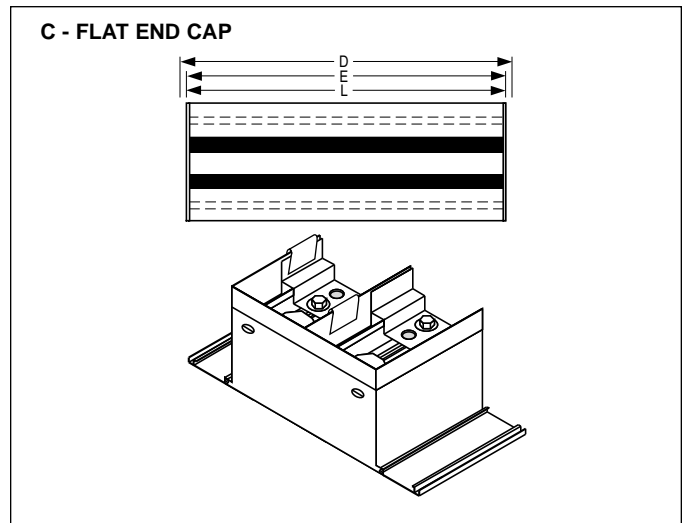
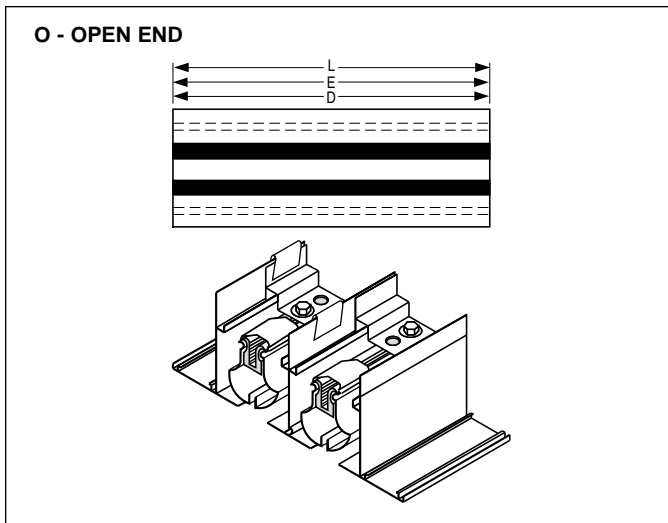
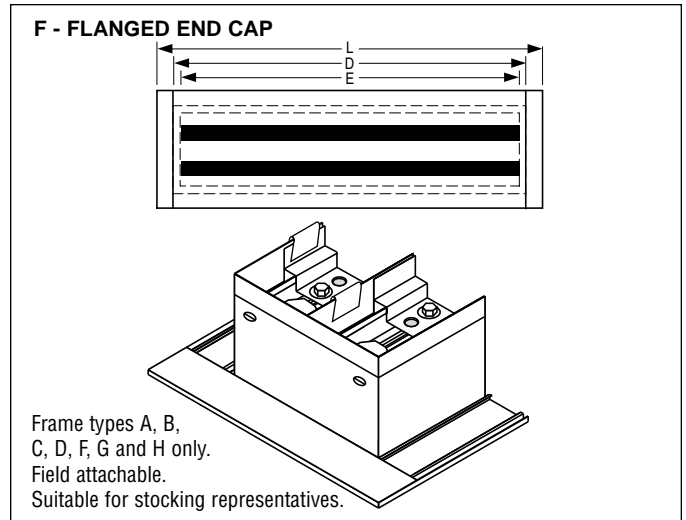
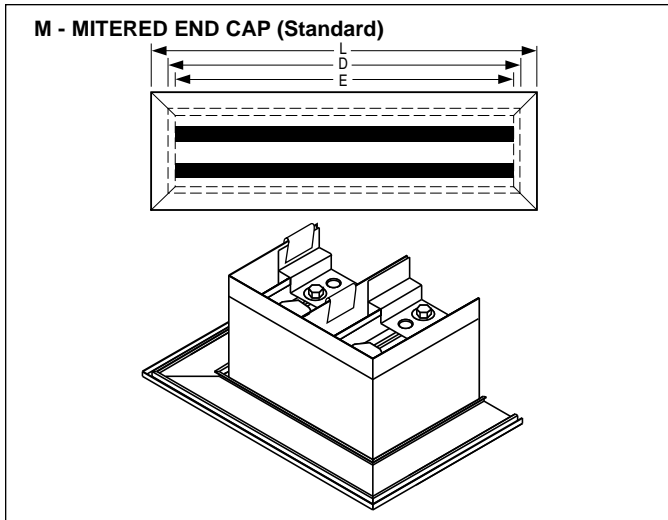

Overall Length Dimensions and End Cap Position

D = Duct Length

E = End Cap Position

L = Overall Length

Frame Type	M		F		M		M		O		O		C		C	
	E	L	E	L	E	L †	E	L †	E	L	E	L	E	L	E	L
A, B	D-1/2 (13)	D+1 (25)	D-1/2 (13)	D+1 1/2 (38)	D-1/4 (6)	D+1/2 (13)	D-3/16 (5)	D+9/16 (14)	D	D	D-1/16 (2)	D-1/16 (2)	D-1/8 (3)	D-1/8 (3)		
C	D-1/2 (13)	D+1 (25)	D-1/2 (13)	D+1 1/2 (38)	D-1/4 (6)	D+1/2 (13)	D-3/16 (5)	D+9/16 (14)	D	D	D-1/16 (2)	D-1/16 (2)	D-1/8 (3)	D-1/8 (3)		
D	D-1/2 (13)	D+1/2 (13)	D-1/2 (13)	D+1 (25)	D-1/4 (6)	D+1/4 (6)	D-3/16 (5)	D+7/16 (11)	D	D	D-1/16 (2)	D-1/16 (2)	D-1/8 (3)	D-1/8 (3)		
E	D-7/8 (22)	D	-	-	D-7/16 (11)	D	D-3/8 (10)	D+1/16 (2)	D	D	D-1/16 (2)	D-1/16 (2)	D-1/8 (3)	D-1/8 (3)		
F, H	D-3/4 (19)	D+3/4 (19)	D-3/4 (19)	D+3/4 (19)	D-3/8 (10)	D+3/8 (10)	D-5/16 (8)	D+7/16 (11)	D	D	D-1/16 (2)	D-1/16 (2)	D-1/8 (3)	D-1/8 (3)		
G	D-1/8 (3)	D	D-1/8 (3)	D	D-9/16 (14)	D	D-1/2 (13)	D+1/16 (2)	D	D	D-1/16 (2)	D-1/16 (2)	D-1/8 (3)	D-1/8 (3)		
M*, N*	D-1/16 (2)	D-1/16 (2)	-	-	D-1/32 (1)	D-1/32 (1)	D-1/16 (2)	D-1/16 (2)	D	D	D-1/16 (2)	D-1/16 (2)	D-1/8 (3)	D-1/8 (3)		

† Configurations **FO** and **FC**: Add 1/4" (6) for frame types A, B, C, D, F, G and H. Not available on frame types E, M and N.

Dimensions are in inches (mm).

* These types have a flangeless mitered end cap which is the same extrusion profile as the frame.

Standard Lay-in T-Bar Application

Designed and fabricated specifically to integrate with standard exposed grid T-Bar Ceiling Systems.

Available in nominal lengths to suit both imperial and metric ceiling grid modules.

Imperial module lengths: 20", 24", 48" and 60".

Metric module lengths: 500, 600, 1200 and 1500 mm.

Also available in custom lengths for special applications and in multiple section assemblies for continuous paired T-Bar ceilings.

Type T Frame

- For standard 15/16" (24) or 9/16" (14) face lay-in T-Bar

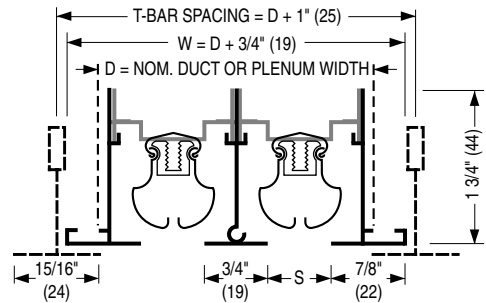

Duct Width D Dimension

(Frames T and FL)

No. of Slots	Imperial Units (inches)			Metric Units (mm)		
	5050 (R) S = 1/2	5075 (R) S = 3/4	5010 (R) S = 1	5050 (R) S = 13	5075 (R) S = 19	5010 (R) S = 25
1	1 1/2	1 3/4	2	38	44	51
2	2 3/4	3 1/4	3 3/4	70	83	95
3	4	4 3/4	5 1/2	102	121	140
4	5 1/4	6 1/4	7 1/4	133	159	184
5	6 1/2	7 3/4	9	165	197	229
6	7 3/4	9 1/4	10 3/4	197	235	273
7	9	10 3/4	12 1/2	229	273	318
8	10 1/4	12 1/4	14 1/4	260	311	362
9	11 1/2	13 3/4	16	292	349	406
10	12 3/4	15 1/4	17 3/4	324	387	451

End Cap Configurations • Type T Frame

Type MM

- Mitered End Caps (standard)

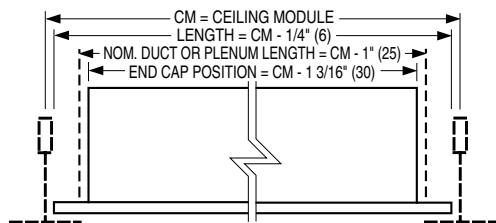

Type CC

- Flat End Caps

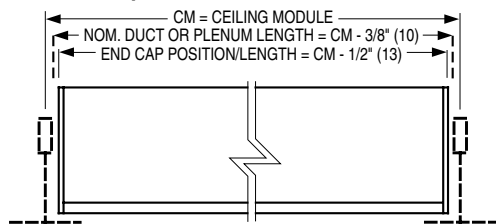

End Cap Configuration • Type FL Frame

Type MM

- Mitered End Caps (standard)

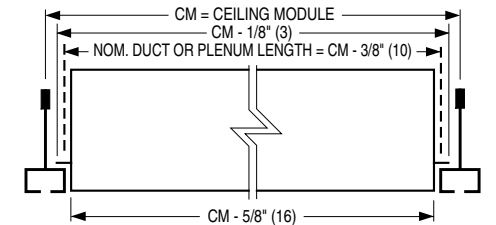

Fineline® Type Ceiling Systems

Nailor can fabricate the 5000 Series to integrate with most available Fineline® or Regressed T-Bar type ceiling systems.

The Type FL frame is compatible with both the USG Interiors Inc. 'Donn Fineline®' and Chicago Metallic Corporation 'Ultraline®' 3500/3600 systems. For other ceiling systems, contact your Nailor representative.

¹Fineline® is a registered trademark of USG Interiors Inc.

²Ultraline® is a registered trademark of Chicago Metallic Corporation.

Type FL Frame

- For Fineline® type ceilings

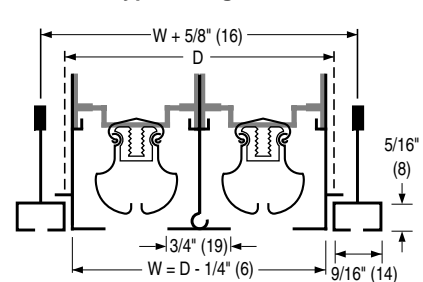

Options and Accessories

90° Mitered Corners

- 5050MC • 1/2" (13) Slot
- 5075MC • 3/4" (19) Slot
- 5010MC • 1" (25) Slot

The standard mitered corner is 90°. Units are factory welded with precision to match and align with the associated straight leg.

Units are supplied with factory installed blank-offs in the slot (painted black) and are inactive. For compound angles, contact your **Nailor** representative.

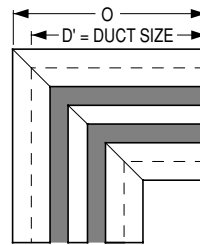

D' = Duct Size	
No. of Slots	D'
1 to 4	12 (305)
5 to 10	24 (610)

90° Mitered Corner Dimension 'O'

No. of Slots	Frame Type				
	A, B	C, F, H	D	E, G, J	M, N
1 - 4	12 9/16 (319)	12 3/8 (314)	12 1/8 (308)	11 7/8 (302)	12 (305)
5 - 10	24 9/16 (624)	24 3/8 (619)	24 1/8 (613)	23 7/8 (606)	24 (610)

Dimensions are in inches (mm).

Plenums

Uninsulated Models:

- 5350 • 1/2" (13) Slot
- 5375 • 3/4" (19) Slot
- 5310 • 1" (25) Slot

Insulated Models:

- 5350I • 1/2" (13) Slot
- 5375I • 3/4" (19) Slot
- 5310I • 1" (25) Slot

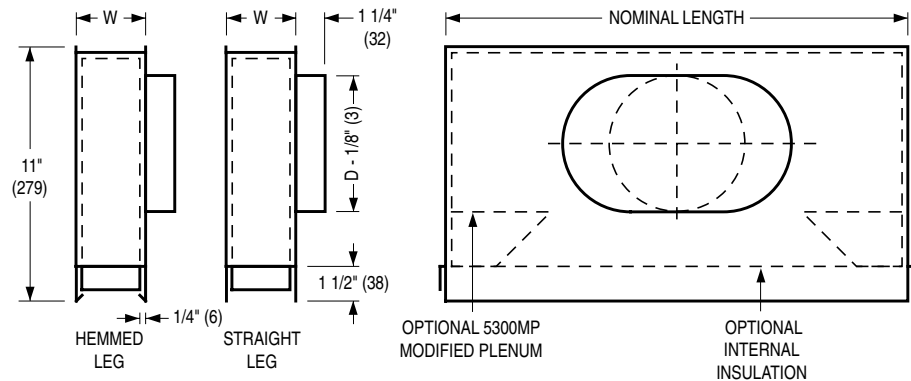

Standard Plenums have square shoulders. An optional modified plenum is available with the addition of integral baffles (add suffix MP) which provides a reduction in throw and increased spread of the air pattern.

Field Trimming of Diffusers

If "X" is less than 3" (76) at either end (6" (152) total), standard **Model 5000** or **5000R** can be field-cut.

- Factory-Cut Diffusers **Model 5000** or **5000R** are ordered for a specific length from the factory, but can be trimmed as much as 6" (152) in length, (3" (76) from each end) with a fine tooth, high speed carbon steel metal cutting blade.

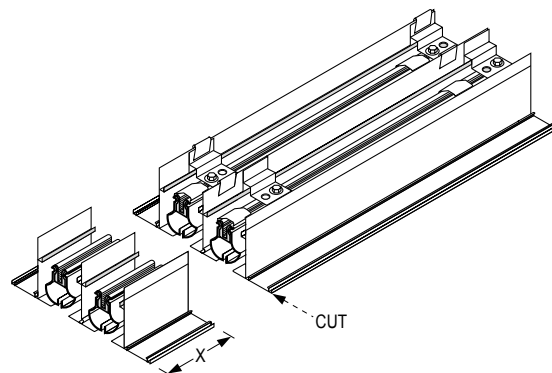

BO Blank-Offs

- Cold-Rolled Steel
- Fits over Neck
- Black Finish

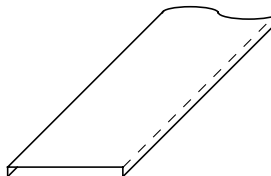

Shipped in 6' (1829) lengths to be field-cut.

Typical Diffuser and Sub-Frame Assembly

Mounting sub-frames are supplied only with Types E, F, G and H.

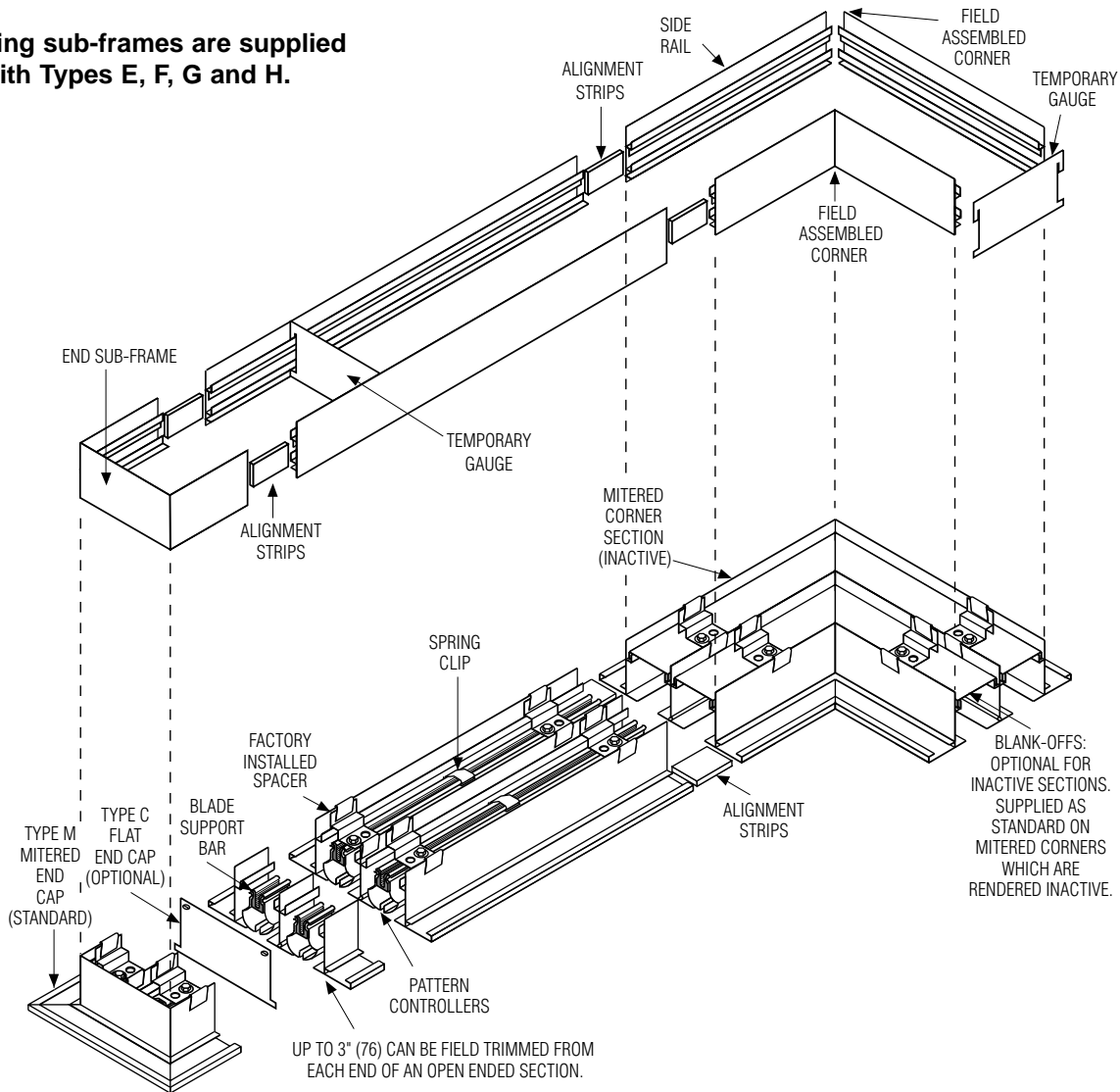

Diffuser Assembly Features:

- Diffusers can be joined together end to end to form long continuous slots.
- The standard Type M end cap is mitered and offers a superior architectural finish on the visible surface.
- The optional Type F end cap can be field installed.
- The optional Type C flat end cap may be used where the diffuser ends at a wall or other stopping point.
- The standard 90° mitered corner section is factory welded and fully assembled to ensure a smooth professional finish. They are inactive.
- Alignment strips are factory supplied as standard on all multiple section frame and sub-frame assemblies and ensure close and positive alignment between sections.

Sub-Frame Features:

- Supplied with Frame Types E, F, G and H.
- Assures a clean, accurately dimensioned opening to receive the diffuser.
- Allows the diffuser to be installed at the end of the job, minimizing risk of damage or contamination from paint or plaster.
- Diffuser can be simply removed and replaced without damage to architectural ceiling finishes.
- Types E, F, G and H are ideal as a wet plaster ground. In this case they should be installed sufficiently proud to allow for the finished ceiling thickness.
- Types E and G are designed to leave a diffuser totally flush with the finished ceiling.
- Types F and H are designed to leave a surface mount diffuser appearance.
- Type E may also be used where a diffuser runs flush along a wall.

Hemmed Duct Preparation

Types C and D

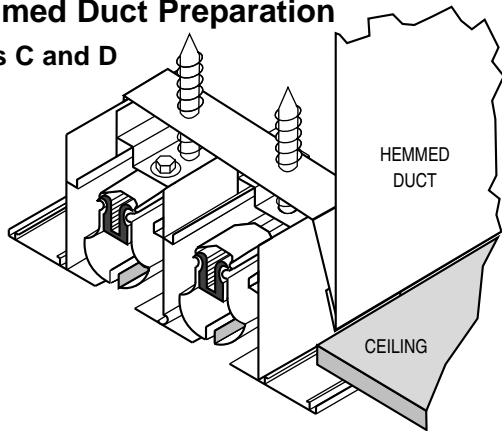

- Far and away the most popular type of installation. Simple and quick.
- Diffuser simply pushes up into duct until the legs of the factory supplied mounting straps locate into the hems of the duct.
- Factory supplied levelling screws then draw the diffuser up until it is tight and snug with the ceiling.
- Duct should be fabricated with a 1/2" (13) hem on both long sides and opened approximately 1/8" (3).

Auxiliary Sub-Frame Preparation

Types E, F, G and H

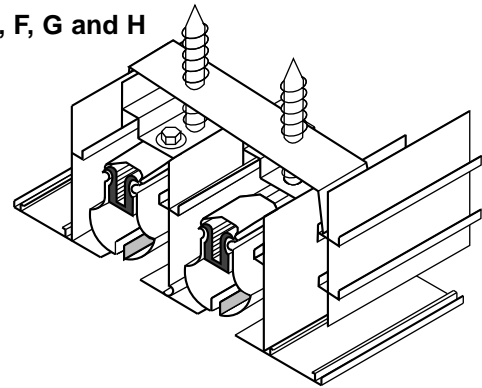

- Sub-frame should be attached to inside of duct and/or a framed ceiling opening as deemed necessary.
- Factory supplied mounting straps locate into an extrusion slot in the sub-frame. Installation of diffuser is similar to the hemmed duct method shown to the left.

Continuous Run Dimensions

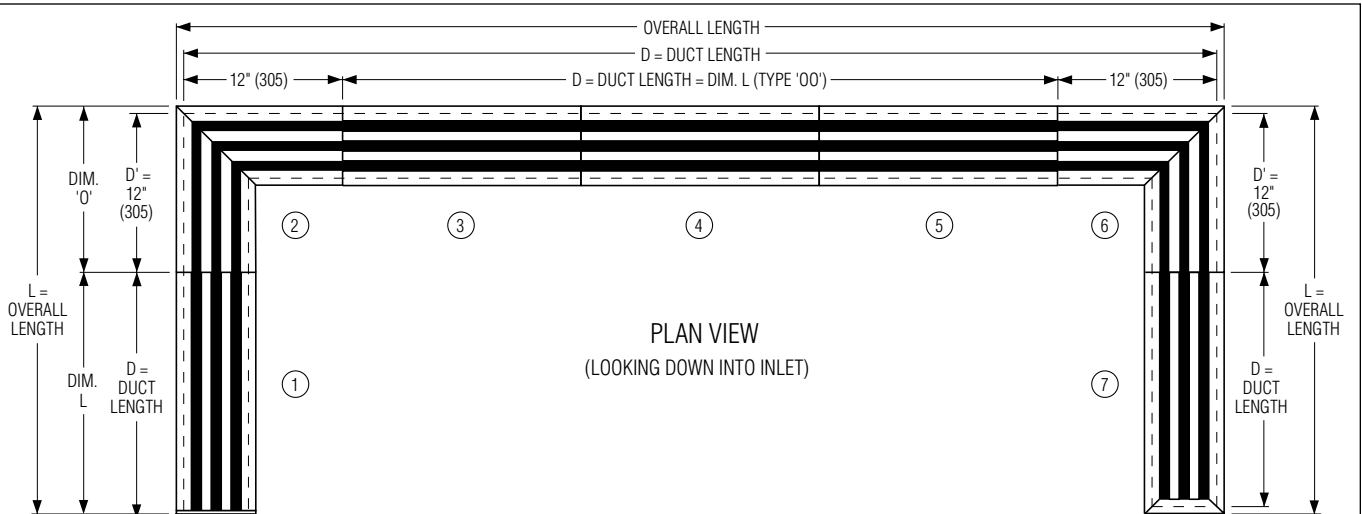

The above example illustrates a typical 3 slot installation with two 90° mitered corner sections.

- ① Type 'CO' End Cap configuration.
- ② and ⑥ 'MC' Mitered Corner Section.
- ③, ④ and ⑤ Type 'OO' End Cap configuration.
- ⑦ Type 'MO' End Cap configuration.

Each straight section, regardless of total duct length may be ordered as a single section.

Example:

- ① and ⑦ Each section may be ordered as a single item, regardless of total length.
- ③, ④ and ⑤ One section may be ordered, regardless of total length.

Multiple sections are sub-divided by the factory into equal length sections at the factories' discretion.

Note: It is extremely difficult to achieve a perfect installation where compound miters are involved, such as above, when all sections are ordered from the factory fabricated to suit finished duct dimensions. This is due to field tolerance variations which may prevent proper alignment and butting together of individual sections due to insufficient material. It is recommended that section ③, ④ or ⑤ is ordered oversize by 3" (76) and field cut to suit field conditions. 'OO' configuration lengths can be trimmed by up to 6" (152). 3" (76) from each end.

HOW TO SPECIFY OR TO ORDER

(Show complete Model Number and Size, unless "Default" is desired).

Extruded Aluminum Linear Slot Diffusers – Model Series 5000

5075 - 48" x 2 Slot - C - AW - MM - —

MODEL

- Linear Slot Diffuser 50

SLOT WIDTH / FABRICATION

- Supply 1/2" (13) 50
 3/4" (19) 75
 1" (25) 10

- Return 1/2" (13) 50R
 3/4" (19) 75R
 1" (25) 10R

- Mitered Corner 1/2" (13) 50MC
 3/4" (19) 75MC
 1" (25) 10MC

- Blank-offs* 1/2" (13) 50BO
 3/4" (19) 75BO
 1" (25) 10BO

NOMINAL LENGTH
 (inches or feet and inches)

NO. OF SLOTS

- 1 thru 10

ACCESSORIES

- Angle Cut One End AC1
 - Angle Cut Both Ends AC2

END CAP CONFIGURATION

- Mitered Mitered (default) MM
 - Mitered Open MO
 - Mitered Flat MC
 - Open Open OO
 - Open Flat OC
 - Flat Flat CC
 - Flanged Flanged FF
 - Flanged Open FO
 - Flanged Flat FC

FINISH

- Appliance White (default) AW
 - Aluminum AL
 - Brushed and Clear Coat Lacquer BC
 - Mill MI
 - Special SP

FRAME OR FRAME/SUB-FRAME COMBINATION

- 1 1/8" Flange Frame, Screw Holes A
 - 1 1/8" Flange Frame, No Screw Holes B
 - 1 1/8" Flange Frame, Concealed Mounting C
 - 7/8" Flange Frame, Concealed Mounting D
 - 3/4" Flush Frame/Sub-frame E
 - 1 1/8" Flange Frame/Sub-frame F
 - 7/8" Flush Frame/Plaster Sub-frame G
 - 1 1/8" Flange Frame/Plaster Sub-frame H
 - Flangeless Frame M
 - Spline Frame, Concealed Mounting N
 - T-Bar Lay-in, 7/8" Flange Frame T
 - Finline® Frame FL

B

LINEAR DIFFUSERS AND BAR GRILLES

Notes:

1. Flanged end caps (FF) may be shipped loose upon request for field attachment and are intended for use with field cut sections or for use by stocking representatives.
2. It is helpful to include a sketch for multiple sectioned units with mitered corners and angle cuts. Specify exact outside length of duct run and angles.
3. For lay-in T-Bar installations, specify nominal T-Bar opening length.
4. *Blank-offs are supplied in 6' (1829) lengths, therefore, 'No of Slots' is the only required variant that needs to be specified.

SUGGESTED SPECIFICATION:

Models 5010, 5075, 5050

Furnish and install **Nailor Model** (select one) **5010** (1" (25) slot), **5075** (3/4" (19) slot), or **5050** (1/2" (13) slot) **Linear Slot Supply Diffusers** of the sizes and capacities as shown on the plans and air distribution schedules. The maximum length of a single section shall be 72" (1829) long. All sizes larger than 72" (1829) will be provided in continuous multiple sections. Alignment strips are to be provided for joining continuous diffuser sections together. The frame borders and end caps shall be extruded aluminum with extruded aluminum spacers. The linear shall be supplied in 1 – 10 slots wide as specified. Pattern deflectors shall have an aerodynamic 'ice tong' shape that can be adjusted to regulate the volume and direction of the airflow. The maximum length of the deflectors shall be 36" (914), longer sizes shall be provided in multiple sections. The pattern deflector finish shall be black. The frame/border finish is to be AW Appliance White baked enamel (optional finishes are available).

The manufacturer shall provide published performance data for the linear slot diffuser, which shall be tested in accordance with ANSI/ASHRAE Standard 70 – 1991.

Models 5010R, 5075R, 5050R

Furnish and install **Nailor Model** (select one) **5010R** (1" (25) slot), **5075R** (3/4" (19) slot), or **5050R** (1/2" (13) slot) **Linear Slot Return Diffusers** of the sizes and capacities as shown on the plans and air distribution schedules. The maximum length of a single section shall be 72" (1829) long. All sizes larger than 72" (1829) will be provided in continuous multiple sections. Alignment strips are to be provided for joining continuous diffuser sections together. The frame border and end caps shall be extruded aluminum with extruded aluminum spacers. The linear shall be supplied in 1 – 10 slots wide as specified. The finish is to be AW Appliance White baked enamel (optional finishes are available).

The manufacturer shall provide published performance data for the linear slot diffuser, which shall be tested in accordance with ANSI/ASHRAE Standard 70 – 1991.

Performance Data

Plenum Supply

Model 5050 • 1/2" (13) Slot

No. of Slots	TP	H V	.005 .003	.020 .014	.041 .027	.074 .051	.120 .083	.173 .116	.230 .158	.310 .215
1	CFM per Ft.		5	10	15	20	25	30	35	40
	T	H V	1-1-1 2	1-1-6 6	1-3-7 9	3-6-9 11	5-7-9 12	6-7-10 13	6-7-10 14	7-8-12 15
	NC		—	14	17	21	26	31	35	38
2	CFM per Ft.		10	20	30	40	50	60	70	80
	T	H V	1-1-3 3	1-3-8 7	3-6-10 12	5-8-11 14	7-9-12 15	8-10-14 17	9-10-15 18	9-11-16 20
	NC		—	15	20	24	28	34	38	41
3	CFM per Ft.		15	30	45	60	75	90	105	120
	T	H V	1-1-5 4	2-5-10 10	5-7-12 15	7-10-14 18	9-10-15 21	10-12-19 22	10-12-20 25	11-14-22 23
	NC		—	16	21	26	31	36	40	43
4	CFM per Ft.		20	40	60	80	100	120	140	160
	T	H V	1-1-6 6	3-6-11 11	6-9-14 16	8-11-16 20	10-12-20 22	11-14-22 24	12-15-24 26	13-16-26 29
	NC		—	17	22	27	32	37	41	44
5	CFM per Ft.		25	50	75	100	125	150	175	200
	T	H V	1-2-7 6	4-7-12 12	7-10-15 20	9-12-20 26	11-14-23 27	13-16-25 30	14-20-26 30	15-20-29 33
	NC		—	18	23	28	33	38	42	45
6	CFM per Ft.		30	60	90	120	150	180	210	240
	T	H V	1-3-7 6	5-7-14 14	7-10-20 20	10-14-22 25	12-16-25 27	14-20-27 30	15-21-29 33	16-23-32 34
	NC		—	19	24	29	34	39	43	46
7	CFM per Ft.		35	70	105	140	175	210	245	280
	T	H V	2-4-7 6	5-7-15 14	8-12-21 22	10-15-24 27	13-20-27 30	15-21-29 32	19-23-32 36	20-24-34 38
	NC		—	19	24	29	34	39	43	46
8	CFM per Ft.		40	80	120	160	200	240	280	320
	T	H V	2-4-9 7	5-8-16 15	9-12-22 24	11-19-26 29	14-20-29 33	16-23-32 36	20-24-34 39	21-26-36 40
	NC		10	20	25	30	35	40	44	47

NC Correction Factors for Various Lengths

Length (ft.)	2	4	6	8	9	10	15	20	25	30
Supply	-3	0	+2	+3	+4	+5	+8	+10	+11	+13
Return	0	+3	+4	+6	+7	+8	+10	+11	+12	+13

Throw Correction Factors for Various Lengths

Length (ft.)	2	4	6	8	10	12
Multiplier	0.70	1.0	1.25	1.40	1.55	1.70

CFM - cubic feet per minute

TP - total pressure - inches w.g.

T - throw in feet

H - horizontal

V - vertical

NC - Noise Criteria (values) based on 10 dB room absorption, re 10⁻¹² watts.

Performance Notes:

- Horizontal throws are based on the same direction of all slots.
- Horizontal throws are given at 150, 100 and 50 fpm terminal velocities.
- Vertical throws are given at 50 fpm terminal velocity.
- Throw values are based on a 4 ft. section. For other lengths, use the correction factor table above.
- NC values are based on a 4 ft. section, horizontal throw. For other lengths, use the correction factor table above. For vertical throw, deduct 10 dB.

6. Data derived from tests conducted in accordance with ANSI/ASHRAE Standard 70 – 1991.

Number of Slots	Ak Factor per foot	
	Supply	Return
1	.018	.033
2	.035	.066
3	.053	.099
4	.070	.132
5	.088	.165
6	.105	.198
7	.123	.231
8	.140	.264

Performance Data

Plenum Supply

Model 5075 • 3/4" (19) Slot

No. of Slots	TP	H	.004	.017	.030	.055	.089	.123	.176	.256
		V	.003	.012	.026	.042	.065	.092	.125	.174
1	CFM per Ft.		5	10	20	25	30	35	40	50
	T	H	1-1-2	1-2-6	2-4-7	3-6-9	5-7-10	6-7-10	7-8-11	7-9-12
		V	2	6	10	12	13	14	15	16
	NC		—	—	16	21	26	30	33	38
2	CFM per Ft.		10	20	40	50	60	70	80	100
	T	H	1-1-3	1-3-9	3-7-10	6-9-12	7-10-14	9-10-15	9-11-19	10-12-20
		V	3	8	11	15	18	20	21	22
	NC		—	—	19	24	29	33	36	41
3	CFM per Ft.		15	30	60	75	90	105	120	150
	T	H	1-1-5	3-5-10	5-8-13	7-10-15	9-12-20	10-13-21	12-14-23	12-15-24
		V	6	10	15	19	20	24	25	27
	NC		—	11	21	26	31	35	38	43
4	CFM per Ft.		20	40	80	100	120	140	160	200
	T	H	1-1-7	3-7-12	7-10-15	9-12-20	10-14-23	12-15-24	14-19-26	14-20-28
		V	5	11	18	21	25	27	30	31
	NC		—	12	22	27	32	36	39	44
5	CFM per Ft.		25	50	100	125	150	175	200	250
	T	H	1-2-7	4-7-14	7-10-20	10-14-23	12-16-25	14-20-27	15-21-29	19-23-32
		V	6	12	18	25	28	30	34	35
	NC		—	13	23	28	33	37	40	45
6	CFM per Ft.		30	60	120	150	180	210	240	300
	T	H	1-3-8	5-8-15	8-12-21	10-15-24	13-20-27	15-21-30	19-23-32	20-25-34
		V	7	13	21	25	30	32	36	39
	NC		—	14	24	29	34	38	41	46
7	CFM per Ft.		35	70	140	175	210	245	280	350
	T	H	2-4-8	6-9-19	9-13-23	12-19-26	14-21-29	19-23-32	20-25-35	22-26-37
		V	8	16	22	29	33	35	40	42
	NC		—	14	24	29	34	38	41	46
8	CFM per Ft.		40	80	160	200	240	280	320	400
	T	H	3-5-9	6-9-20	9-14-24	12-20-28	16-23-32	20-25-34	22-26-37	23-28-39
		V	8	17	21	30	35	40	42	43
	NC		—	15	25	30	35	39	42	47

B LINEAR DIFFUSERS AND BAR GRILLES

NC Correction Factors for Various Lengths

Length (ft.)	2	4	6	8	9	10	15	20	25	30
Supply	-3	0	+2	+3	+4	+5	+8	+10	+11	+13
Return	0	+3	+4	+6	+7	+8	+10	+11	+12	+13

Throw Correction Factors for Various Lengths

Length (ft.)	2	4	6	8	10	12
Multiplier	0.70	1.0	1.25	1.40	1.55	1.70

CFM - cubic feet per minute

TP - total pressure - inches w.g.

T - throw in feet

H - horizontal

V - vertical

NC - Noise Criteria (values) based on 10 dB room absorption, re 10⁻¹² watts.

Performance Notes:

- Horizontal throws are based on the same direction of all slots.
- Horizontal throws are given at 150, 100 and 50 fpm terminal velocities.
- Vertical throws are given at 50 fpm terminal velocity.
- Throw values are based on a 4 ft. section. For other lengths, use the correction factor table above.
- NC values are based on a 4 ft. section, horizontal throw. For other lengths, use the correction factor table above. For vertical throw, deduct 10 dB.

6. Data derived from tests conducted in accordance with ANSI/ASHRAE Standard 70 – 1991.

Number of Slots	Ak Factor per foot	
	Supply	Return
1	.024	.039
2	.049	.078
3	.073	.117
4	.098	.156
5	.122	.195
6	.146	.234
7	.171	.273
8	.195	.312

Performance Data

Plenum Supply

Model 5010 • 1" (25) Slot

No. of Slots	TP	H	.004	.016	.036	.065	.098	.138	.192	.245
		V	.002	.009	.024	.038	.057	.082	.113	.148
1	CFM per Ft.		10	15	25	30	40	50	55	65
	T	H	1-2-5	2-3-5	3-5-7	4-6-8	5-6-9	6-7-10	7-7-10	7-8-11
		V	2	8	12	13	15	16	17	18
	NC		—	—	18	22	29	34	37	41
2	CFM per Ft.		20	30	50	60	80	100	110	130
	T	H	1-3-7	2-4-8	5-7-10	6-8-12	7-9-15	8-10-16	9-13-17	10-15-18
		V	4	10	16	19	20	21	23	25
	NC		—	10	21	25	32	37	40	44
3	CFM per Ft.		30	45	75	90	120	150	165	195
	T	H	2-4-8	5-6-10	6-8-12	7-10-16	9-11-18	10-12-19	11-13-21	12-14-22
		V	6	11	18	22	25	27	30	31
	NC		—	12	23	27	34	39	42	46
4	CFM per Ft.		40	60	100	120	160	200	220	260
	T	H	3-5-10	6-8-12	7-10-16	8-11-18	10-15-21	11-16-22	12-17-24	13-18-26
		V	7	13	21	26	29	30	34	36
	NC		—	13	24	28	35	40	43	47
5	CFM per Ft.		50	75	125	150	200	250	275	325
	T	H	4-6-11	7-8-14	8-11-18	10-13-20	12-17-23	15-18-26	16-19-28	17-20-30
		V	8	15	22	27	30	36	37	40
	NC		—	14	25	29	36	41	44	48
6	CFM per Ft.		60	90	150	180	240	300	330	390
	T	H	4-7-12	7-9-15	8-12-19	10-16-22	15-18-26	16-20-27	17-22-29	18-23-31
		V	8	17	26	30	34	36	41	44
	NC		—	15	26	30	37	42	45	49
7	CFM per Ft.		70	105	175	210	280	350	385	455
	T	H	5-7-15	8-11-17	10-15-21	11-17-23	16-20-28	18-21-30	19-23-32	20-24-34
		V	9	18	28	32	37	41	43	48
	NC		—	15	26	30	37	42	45	49
8	CFM per Ft.		80	120	200	240	320	400	440	520
	T	H	5-7-16	8-11-18	10-16-22	13-18-26	18-21-30	19-22-31	21-24-33	22-26-36
		V	11	20	30	35	40	45	50	51
	NC		—	16	27	31	38	43	46	50

NC Correction Factors for Various Lengths

Length (ft.)	2	4	6	8	9	10	15	20	25	30
Supply	-3	0	+2	+3	+4	+5	+8	+10	+11	+13
Return	0	+3	+4	+6	+7	+8	+10	+11	+12	+13

Throw Correction Factors for Various Lengths

Length (ft.)	2	4	6	8	10	12
Multiplier	0.70	1.0	1.25	1.40	1.55	1.70

CFM - cubic feet per minute

TP - total pressure - inches w.g.

T - throw in feet

H - horizontal

V - vertical

NC - Noise Criteria (values) based on 10 dB room absorption, re 10⁻¹² watts.

Performance Notes:

1. Horizontal throws are based on the same direction of all slots.

2. Horizontal throws are given at 150, 100 and 50 fpm terminal velocities.

3. Vertical throws are given at 50 fpm terminal velocity.

4. Throw values are based on a 4 ft. section. For other lengths, use the correction factor table above.

5. NC values are based on a 4 ft. section, horizontal throw. For other lengths, use the correction factor table above. For vertical throw, deduct 10 dB.

6. Data derived from tests conducted in accordance with ANSI/ASHRAE Standard 70 – 1991.

Number of Slots	Ak Factor per foot	
	Supply	Return
1	.030	.044
2	.060	.088
3	.090	.132
4	.121	.176
5	.151	.220
6	.181	.264
7	.211	.308
8	.241	.352

Performance Data

Plenum Return

Model 5050R • 1/2" (13) Slot

No. of Slots	SP	.011	.024	.045	.070	.108	.184	.279	.421
1	CFM per Ft.	10	15	20	25	30	40	50	60
	NC	—	—	—	20	26	34	39	45
2	CFM per Ft.	20	30	40	50	60	80	100	120
	NC	—	—	—	23	28	37	42	48
3	CFM per Ft.	30	45	60	75	90	120	150	180
	NC	—	—	—	25	31	39	44	50
4	CFM per Ft.	40	60	80	100	120	160	200	240
	NC	—	—	20	26	30	38	45	51
5	CFM per Ft.	50	75	100	125	150	200	250	300
	NC	—	—	21	27	32	40	45	53
6	CFM per Ft.	60	90	120	150	180	240	300	360
	NC	—	—	22	29	33	41	46	53
7	CFM per Ft.	70	105	140	175	210	280	350	420
	NC	—	—	23	29	34	42	47	53
8	CFM per Ft.	80	120	160	200	240	320	400	480
	NC	—	—	23	30	34	43	48	54

Model 5075R • 3/4" (19) Slot

No. of Slots	SP	.006	.028	.065	.110	.170	.250	.350	.465
1	CFM per Ft.	10	20	30	40	50	60	70	80
	NC	—	—	—	25	30	38	42	46
2	CFM per Ft.	20	40	60	80	100	120	140	160
	NC	—	—	21	29	35	40	46	49
3	CFM per Ft.	30	60	90	120	150	180	210	240
	NC	—	—	23	31	38	42	47	51
4	CFM per Ft.	40	80	120	160	200	240	280	320
	NC	—	—	24	33	38	44	47	52
5	CFM per Ft.	50	100	150	200	250	300	350	400
	NC	—	—	25	33	40	44	48	53
6	CFM per Ft.	60	120	180	240	300	360	420	480
	NC	—	—	26	34	40	45	49	54
7	CFM per Ft.	70	140	210	280	350	420	490	560
	NC	—	—	27	35	40	46	49	54
8	CFM per Ft.	80	160	240	320	400	480	560	640
	NC	—	—	28	36	41	46	49	56

Model 5010R • 1" (25) Slot

No. of Slots	SP	.020	.045	.070	.110	.165	.215	.291	.471
1	CFM per Ft.	20	30	40	50	60	70	80	100
	NC	—	—	—	25	30	34	38	45
2	CFM per Ft.	40	60	80	100	120	140	160	200
	NC	—	—	22	28	33	36	40	48
3	CFM per Ft.	60	90	120	150	180	210	240	300
	NC	—	—	24	30	35	38	43	50
4	CFM per Ft.	80	120	160	200	240	280	320	400
	NC	—	—	25	31	35	40	45	51
5	CFM per Ft.	100	150	200	250	300	350	400	500
	NC	—	—	25	32	37	41	45	51
6	CFM per Ft.	120	180	240	300	360	420	480	600
	NC	—	—	27	33	38	42	47	53
7	CFM per Ft.	140	210	280	350	420	490	560	700
	NC	—	20	28	34	40	42	48	53
8	CFM per Ft.	160	240	320	400	480	560	640	800
	NC	—	20	28	34	40	43	48	54

CFM - cubic feet per minute

SP - negative static pressure - inches w.g.

NC - Noise Criteria (values) based on 10 dB room absorption, re 10⁻¹² watts.

Performance Notes:

- NC values are based on a 10 ft. active section. For other lengths, use the correction factor table below.
- Data derived from tests conducted in accordance with ANSI/ASHRAE Standard 70 - 1991.

NC Correction Factors for Various Lengths

Length (ft.)	2	4	6	8	9	10	15	20	25	30
Correction	-8	-5	-4	-2	-1	0	+2	+3	+4	+5

B
LINEAR DIFFUSERS AND BAR GRILLES