

## LINEAR BAR GRILLES

- FIXED BARS
- ALUMINUM CONSTRUCTION

### Models:

#### 1/2" (13) Bar Spacing

- 49-240 • 1/4" (6) Bars • 0° Deflection • Pencil-Proof
- 49-241 • 1/4" (6) Bars • 15° Deflection • Pencil-Proof
- 49-243 • 1/4" (6) Bars • 30° Deflection • Pencil-Proof
- 49-280 • 1/8" (3) Bars • 0° Deflection
- 49-281 • 1/8" (3) Bars • 15° Deflection

#### 1/4" (6) Bar Spacing

- 49-480 • 1/8" (3) Bars • 0° Deflection
- 49-481 • 1/8" (3) Bars • 15° Deflection

- Suffix '-O' adds a steel damper

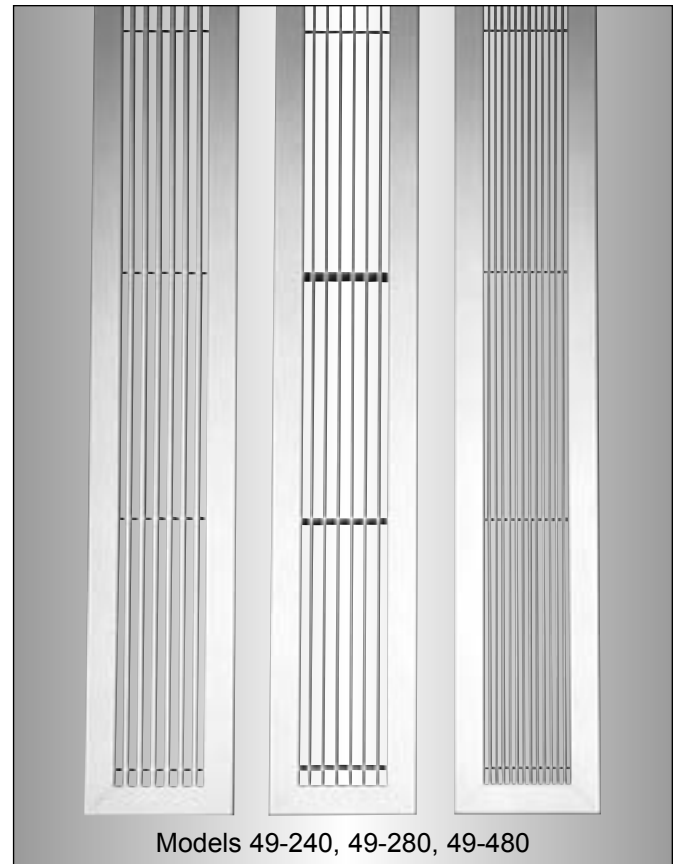

B

LINEAR DIFFUSERS AND BAR GRILLES

The **Model Series 4900 Linear Bar Grilles** have been specially designed to provide the precision quality appearance required for architectural excellence with crisply sculptured styling, careful workmanship and effective air distribution.

The **Series 4900 Linear Bar Grilles** are designed for heating and cooling applications, supply and return.

The grilles are manufactured with precision mitered corners to maximize quality.

### FEATURES:

- Deflection bars are fixed and are parallel to the long dimension.
- Available in 7 core styles and a variety of frame and sub-frame options.
- Diffusers are supplied in lengths of up to 6 ft. (1829) in a single section.
- Standard incremental units of length are 1, 2, 3, 4, 5 and 6 ft. (305, 610, 914, 1219, 1524 and 1829 mm). However, the 4900 Series is available in any nominal length to suit engineering and architectural requirements.
- Ideal for continuous length applications.
- Multiple sections are provided with alignment strips on the frame and sub-frame to provide superior, positive field alignment.
- End caps are staked and mitered for a superior quality appearance.
- Standard duty models are available for ceiling, wall or sill installations. Heavy duty models are designed specifically for use in floor installations.

### Options:

- Heavy gauge steel opposed blade damper (add suffix '-O').
- DV Rear directional control vanes.
- MC Mitered Corner Sections.
- AD Access Doors.
- BO Blank-offs.

**Material:** Extruded Aluminum.

**Finish:** Standard finish is AW Appliance White baked enamel.

Optional finish is AL Aluminum baked enamel.

Premium finishes are SA Satin (clear) Anodized or BC Brushed and Clear Coat lacquer.

Other finishes are available.

## Dimensional Data

### Standard Duty Frame Types

#### Type A

- 1" (25) Border

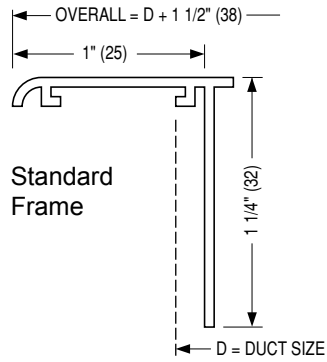

#### Type B

- 3/4" (19) Reduced Border

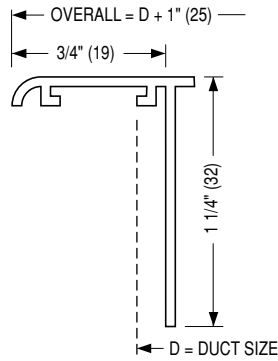

#### Type C

- 1" (25) Border and Sub-Frame

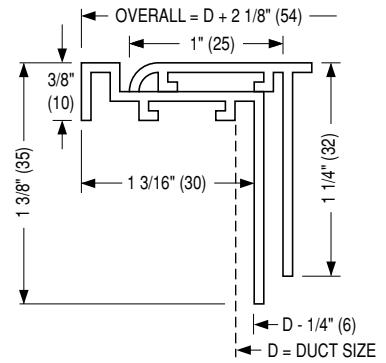

#### Type D

- 1" (25) Border
- Deep Stack (permits DV option)

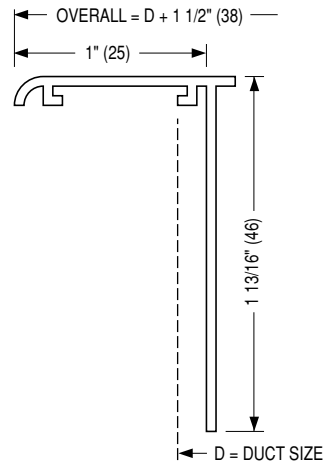

#### Type E

- 1/2" (13) Narrow Border

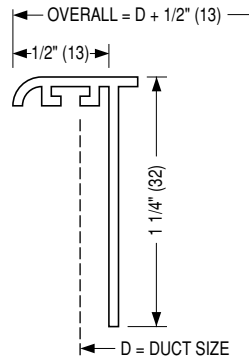

B

LINEAR DIFFUSERS AND BAR GRILLES

### Heavy Duty Mounting Frames for Floor Installations

#### Type F

- 1" (25) Border Flange

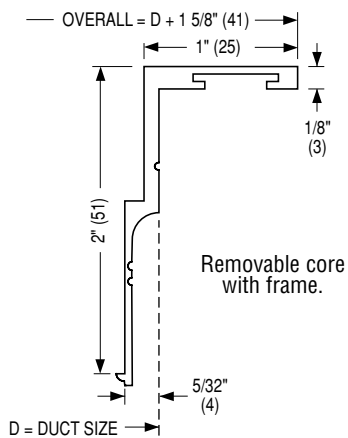

#### Type G

- No Flange
- Flush Mounting

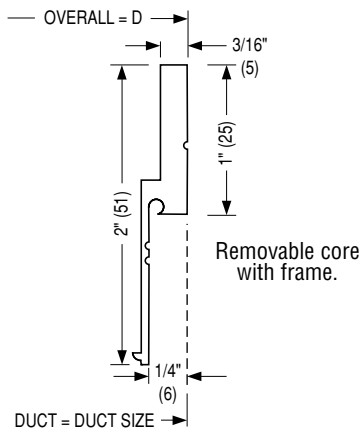

#### Type H

- 3/4" (19) Beveled Border

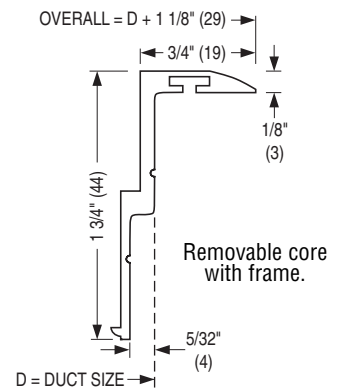

## Dimensional Data

### Available Core Styles

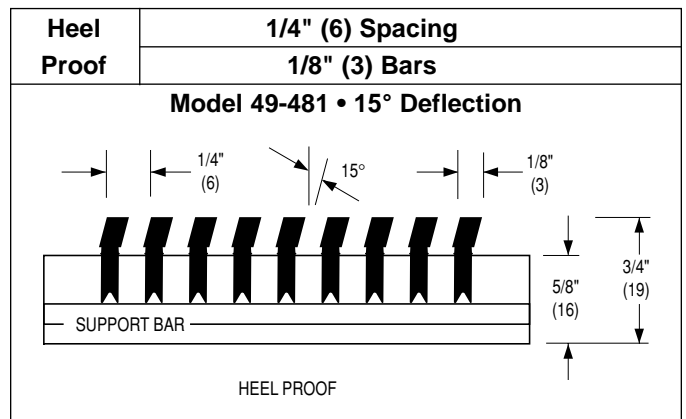
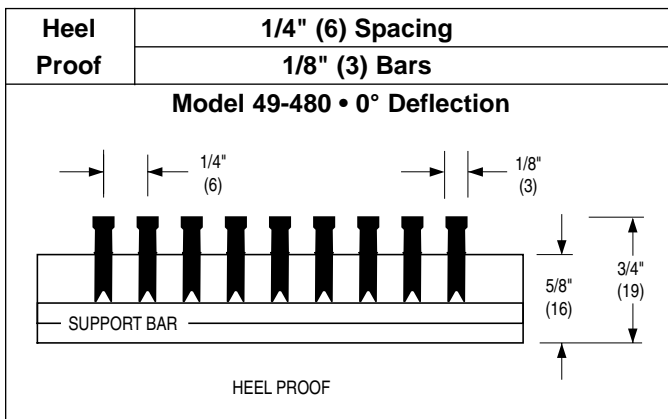
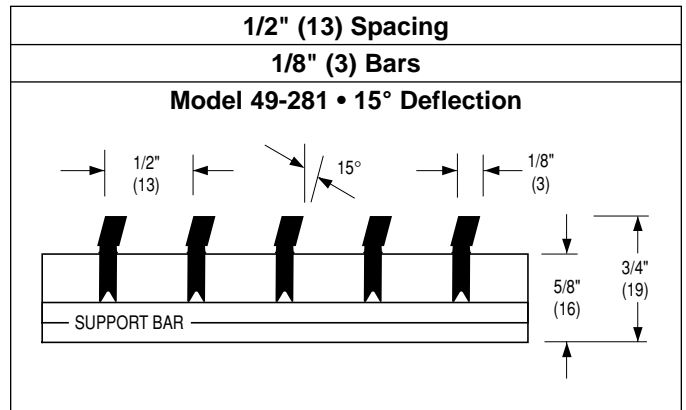
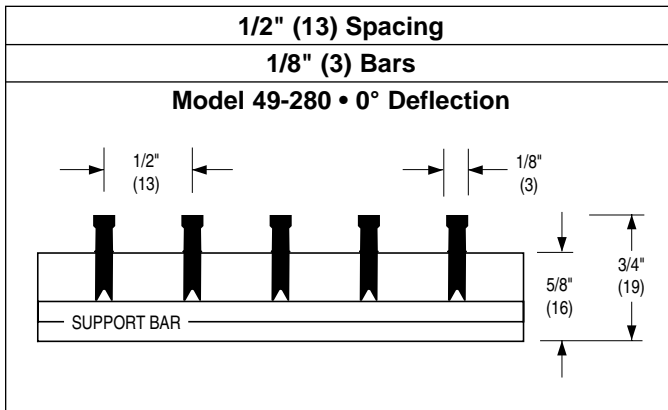
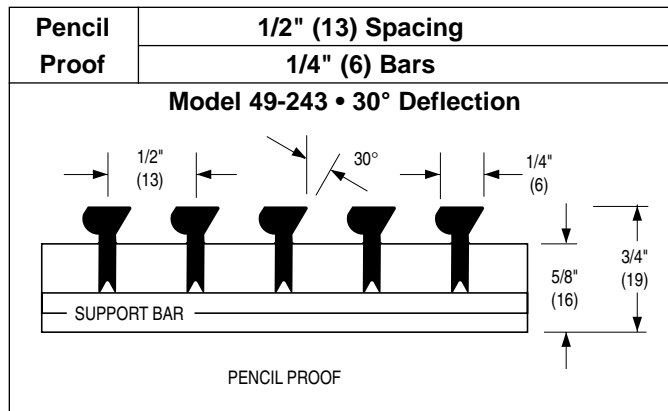
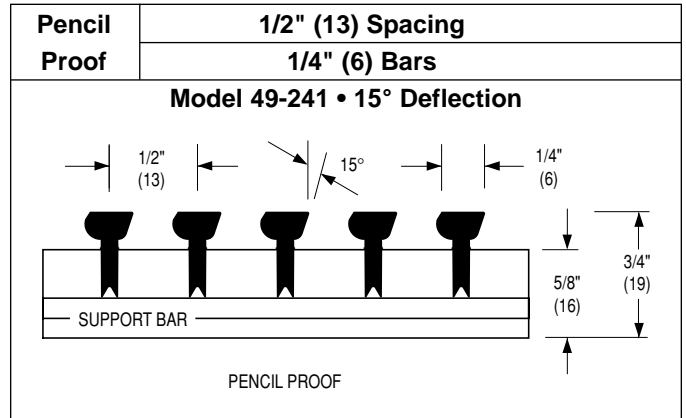
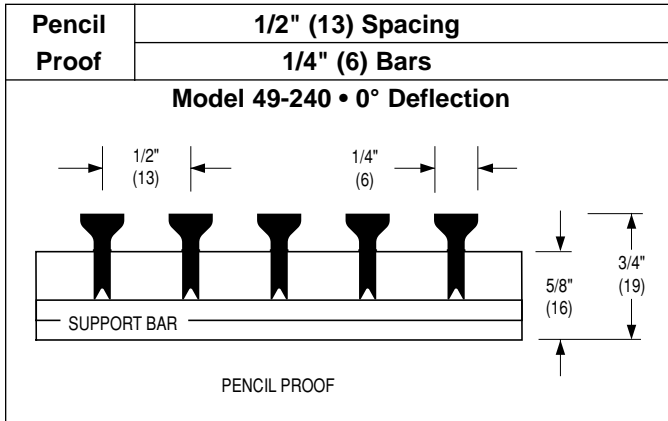

**B**

LINEAR DIFFUSERS AND BAR GRILLES

## Dimensional Data

### Overall Length and Width

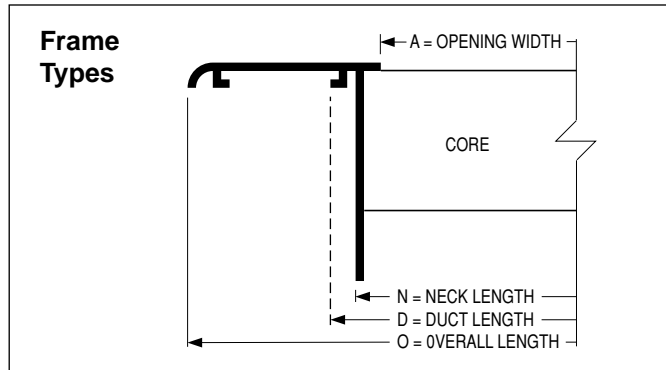

Type	N	O
A	D - 1/2" (13)	D + 1 1/2" (38)
B	D - 1/2" (13)	D + 1" (25)
D	D - 1/2" (13)	D + 1 1/2" (38)
E	D - 1/2" (13)	D + 1/2" (13)
F	D	D + 1 5/8" (41)
G	D	D
H	D	D + 1 1/8" (29)

Dimensions are for length or width.

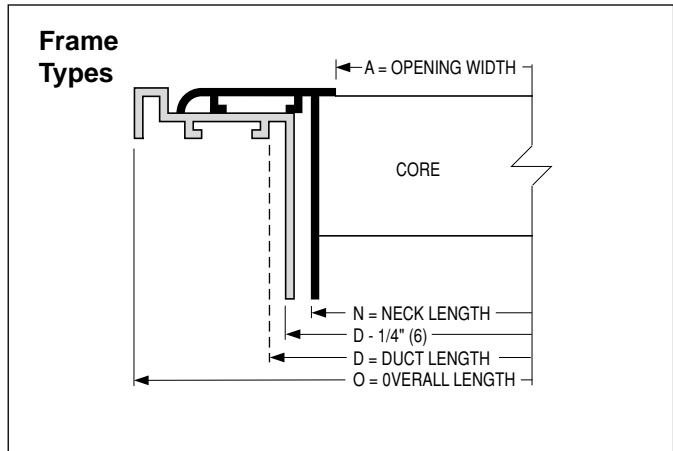

Type	N	O
C	D - 1/2" (13)	D + 2 1/8" (54)

Dimensions are for length or width.

### Standard Widths and Core

Duct Width D	1/4" (6) Spacing	
	Opening Width A	Number of Bars
1 1/2 (38)	3/4 (19)	2
2 (51)	1 1/4 (32)	4
2 1/2 (64)	1 3/4 (44)	6
3 (76)	2 1/4 (57)	8
3 1/2 (89)	2 3/4 (70)	10
4 (102)	3 1/4 (83)	12
5 (127)	4 1/4 (108)	16
6 (152)	5 1/4 (133)	20

Duct Width D	1/2" (13) Spacing	
	Opening Width A	Number of Bars
1 1/2 (38)	3/4 (19)	1
2 (51)	1 1/4 (32)	2
2 1/2 (64)	1 3/4 (44)	3
3 (76)	2 1/4 (57)	4
3 1/2 (89)	2 3/4 (70)	5
4 (102)	3 1/4 (83)	6
5 (127)	4 1/4 (108)	8
6 (152)	5 1/4 (133)	10

For frames types F, G & H increase the number of bars by two.

For frames types F, G & H increase the numbers of bars by one.

Dimensions are in inches (mm).

### Cross-Bar Spacing

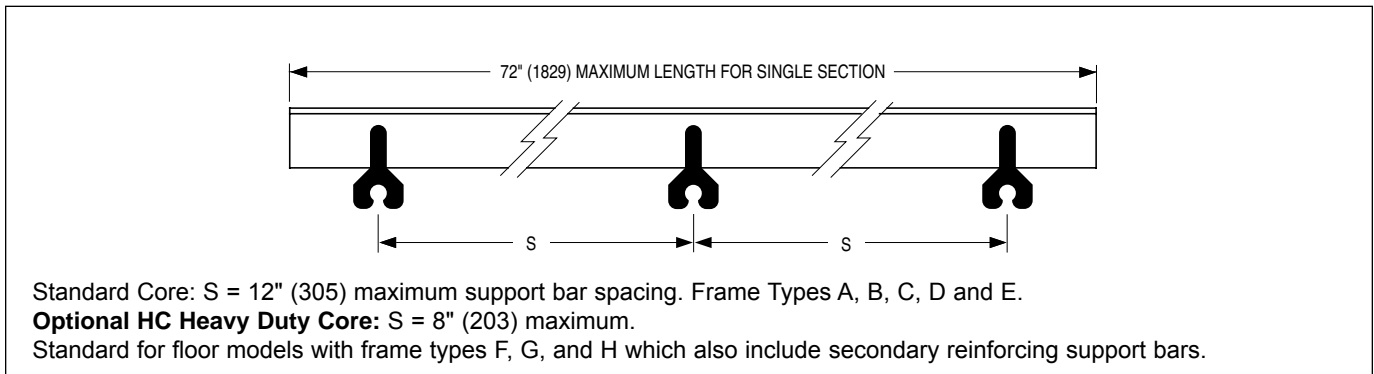

**B** LINEAR DIFFUSERS AND BAR GRILLES

## Dimensional Data

### Typical Frame/Core Assemblies

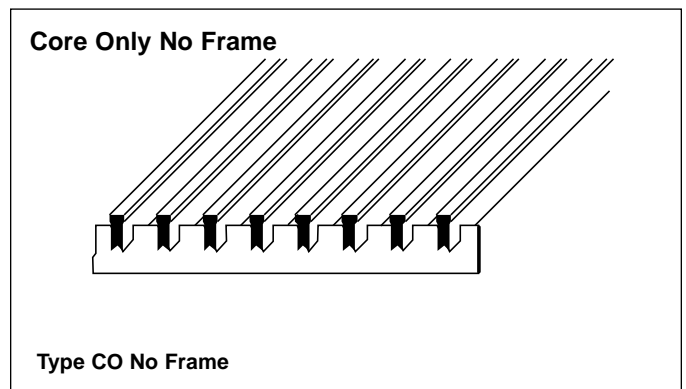
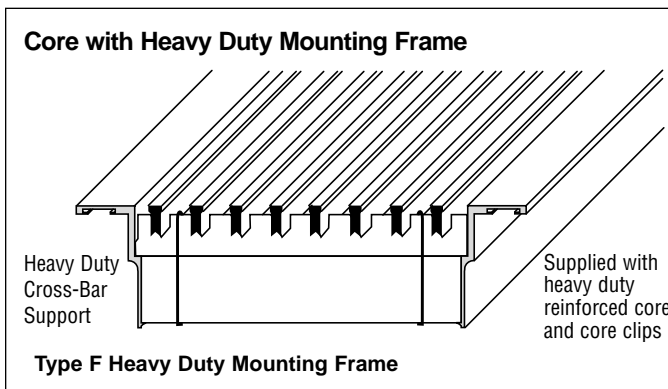
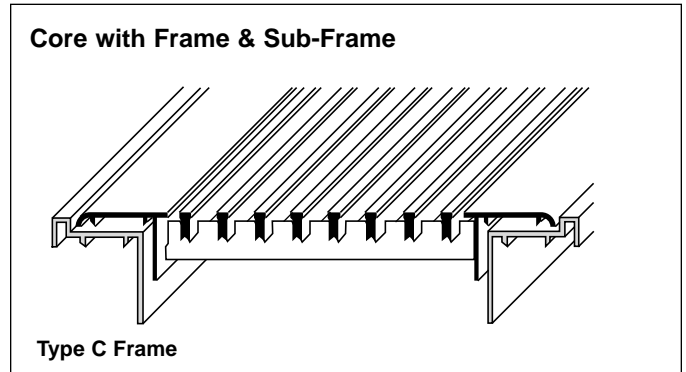
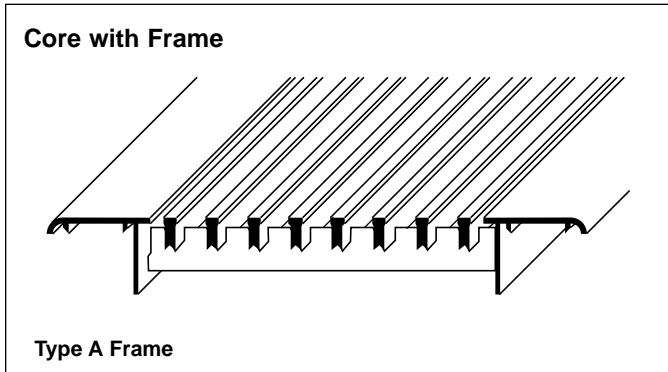

### Fastenings

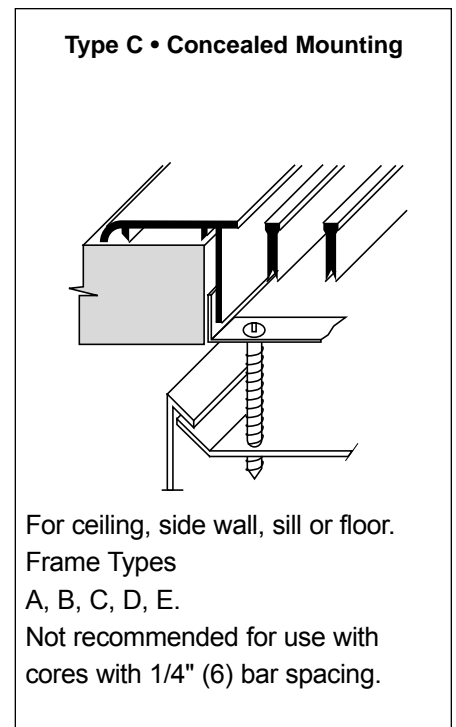
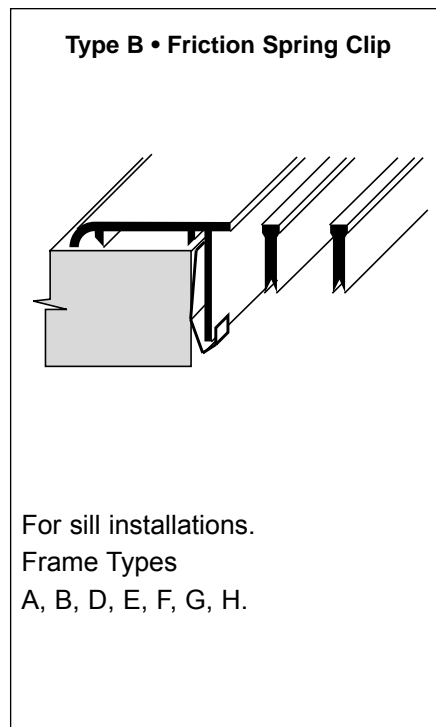
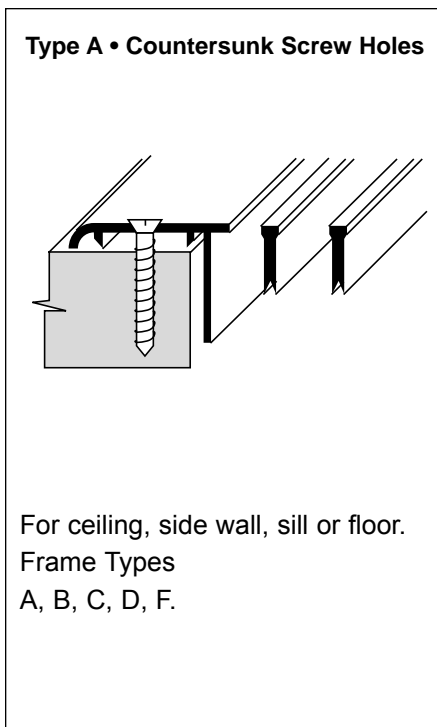

## Dimensional Data

### Mitered Corner Sections

49-240MC  
49-241MC  
49-243MC  
49-280MC

49-281MC  
49-480MC  
49-481MC

Factory welded with precision to match and align with the associated straight leg. Standard mitered corner section for floor, ceiling or wall is 90°. Other angles are available.

#### Application Pattern

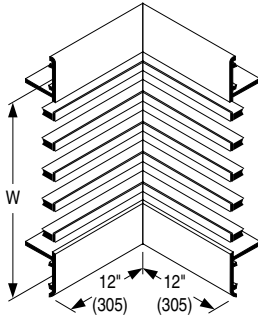

Type WC – Sidewall, inside

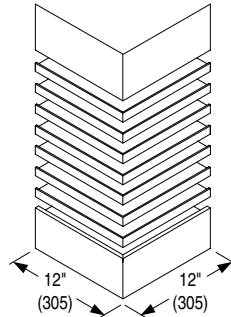

Type WD – Sidewall, outside

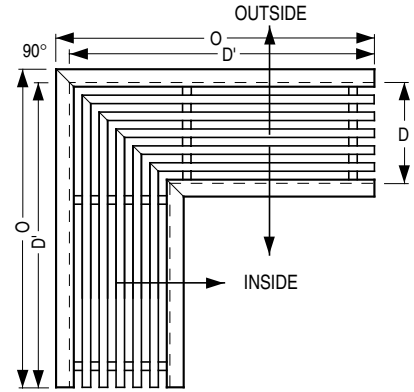

#### Floor, Ceiling or Sill

- Type FO • 0° deflection
- Type FA • Deflection inside
- Type FB • Deflection outside

#### 90° Mitered Corner Dimension 'O'

Duct Width D	Duct Length D'	Frame Type						
		A, D	B	C	E	F	G	H
1 1/2" – 4"	12"	12 3/4" (324)	12 1/2" (318)	13 1/16" (332)	12 1/4" (311)	12 13/16" (325)	12" (305)	12 9/16" (320)
4 1/2" – 12"	18"	18 3/4" (476)	18 1/2" (470)	19 1/16" (613)	18 1/4" (606)	18 13/16" (610)	18" (457)	18 9/16" (471)

B

LINEAR DIFFUSERS AND BAR GRILLES

### Continuous Run Dimensions

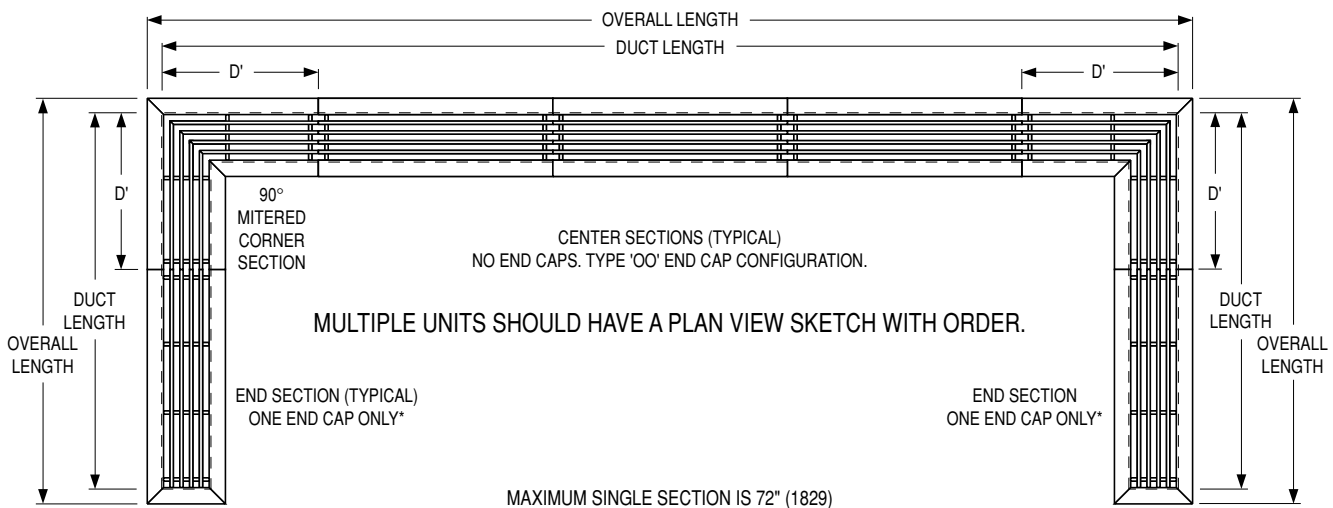

\*End sections with single end caps and deflecting cores must be specified and ordered with the desired core deflection direction. End cap configurations (mitered end cap one end and open opposite end):

Type 'MO' = 0° deflection

Type 'MU' = 15° or 30°

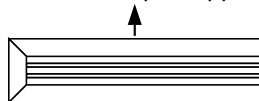

Type 'MD' = 15° or 30°

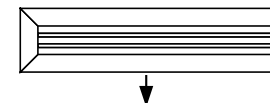

## Options and Accessories

### Type DV Directional Vanes

For all available widths.  
Fully adjustable extruded aluminum blades on 3/4" (19) centers perpendicular to length.

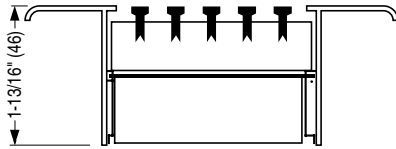

Requires Frame Type D (deep stack), F, G or H

### Single Blade Damper

Friction hinge on 1 1/2" (38) and 2" (51) widths.

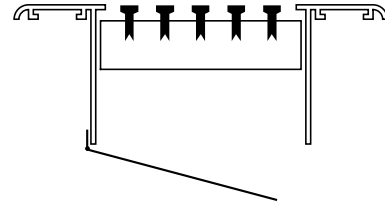

### Opposed Blade Damper

For linear bar grilles with a nominal duct width of 2 1/2" (64) and wider.

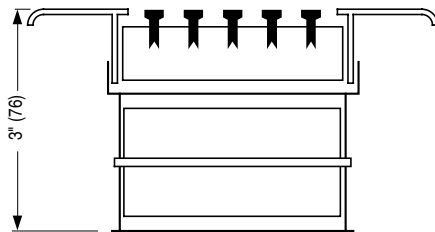

### Access Doors

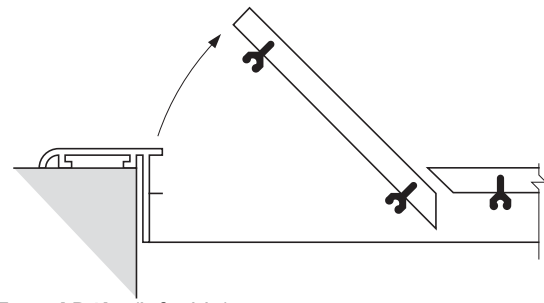

Type AD1L (left side)

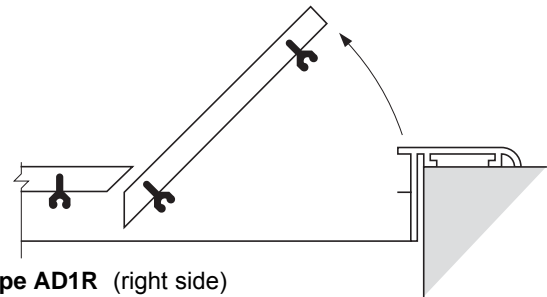

Type AD1R (right side)

### Type BO Steel Blank-Off

For all available widths. Supplied in 6' (1829) lengths for field cutting. Steel, painted black.

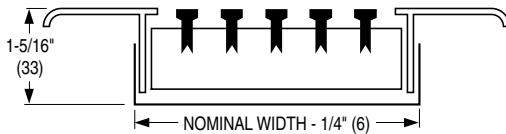

NOMINAL WIDTH - 1/4" (6)

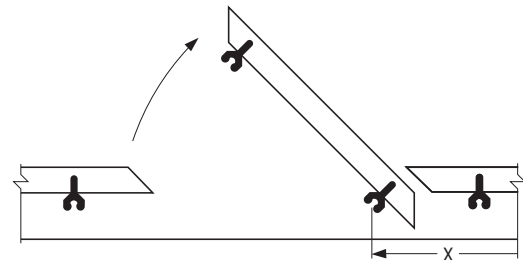

### CENTER SECTION:

Type AD3L

Type AD3R (not shown)

Specify 'X' dim. (distance from end of grille frame)

Access door is a 6" (152) core section hinged on one side.

When selected with a deflected core, specify deflection:

**Sill/Floor - To the front**    **Wall - Up**

**- To the rear**                      **- Down**

### Alignment Strips

Supplied as standard on multiple section assemblies to provide positive and accurate field alignment, except frame G which uses alignment pins.

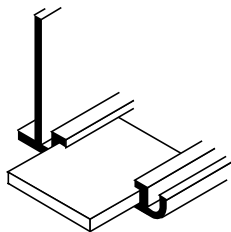

## Typical Opening Preparations

### Ceiling 1

Frame Types A, B, D, or E

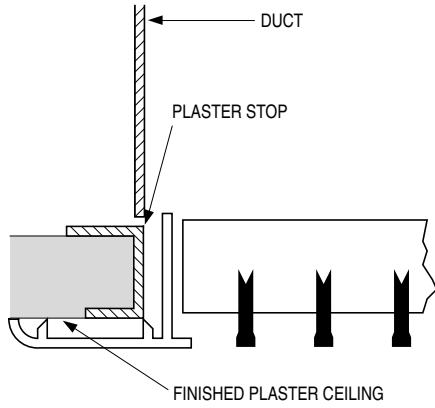

### Floor or Sill 1

Frame Types F or H

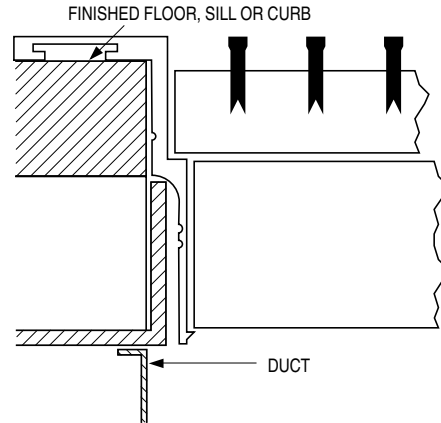

### Floor or Sill 2

Frame Type G

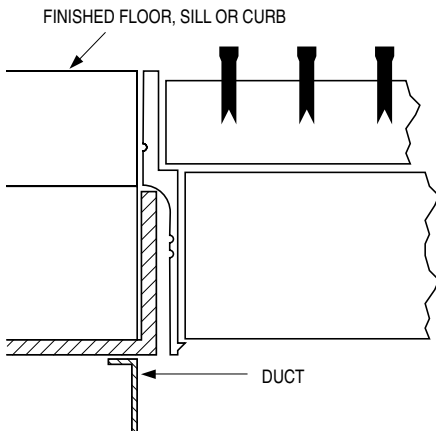

### Raised Sill 1

Core Only

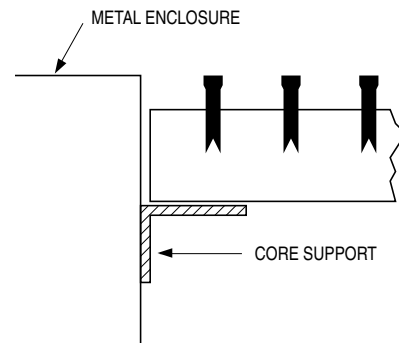

### Raised Sill 2

Frame Types A, B, D, or E

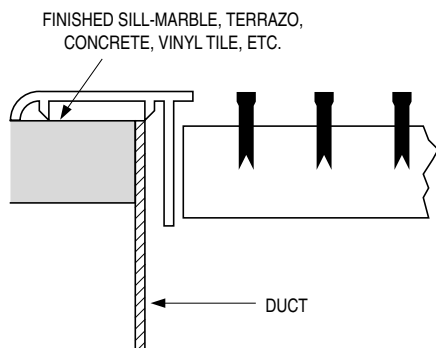

### Side Wall 1

Frame Types A, B, D, or E

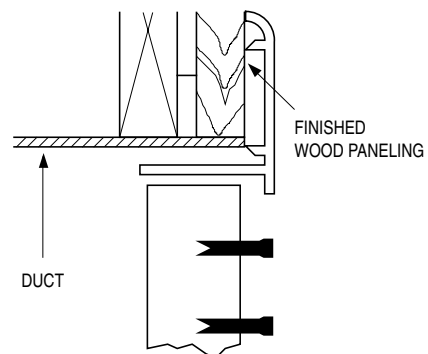

**B**



LINEAR DIFFUSERS AND BAR GRILLES

## HOW TO SPECIFY OR TO ORDER

(Show complete Model Number and Size, unless "Default" is desired).

### Extruded Aluminum Linear Bar Grilles – Model Series 4900

**49 - 2 4 0 - O - 60" x 4" - B - AW - C - MM - —**

<p><b>MODEL</b> _____</p> <p>- Linear Bar Grille</p> <p><b>BAR SPACING</b> _____</p> <p>- 1/2"                    2</p> <p>- 1/4"                    4</p> <p><b>BAR WIDTH</b> _____</p> <p>- 1/4"                    4</p> <p>- 1/8"                    8</p> <p><b>BAR DEFLECTION</b> _____</p> <p>- 0°                      0</p> <p>- 15°                    1</p> <p>- 30°                    3</p> <p><b>DAMPER</b> _____</p> <p>- No Damper (default)    —</p> <p>- With Damper            O</p> <p><b>LENGTH x WIDTH (inches)</b> _____</p> <p><b>FRAME OR FRAME/SUB-FRAME COMBINATION</b> _____</p> <p>- 1" (25)                    A</p> <p>- 3/4" (19)                  B</p> <p>- 1" (25) and Sub-Frame    C</p> <p>- 1" (25) with Deep Neck    D</p> <p>- 1/2" (13)                  E</p> <p>- 1" (25) Heavy Duty        F</p> <p>- No Flange Heavy Duty     G</p> <p>- 3/4" (19) Heavy Duty      H</p> <p>- No Frame Core Only      CO</p>	<p><b>ACCESSORIES</b></p> <p>- None (default)            —</p> <p>- Blank-Offs                BO</p> <p>- Access Door                AD</p> <p>- Heavy Duty Core          HC</p> <p>- Deflector Vanes          DV</p> <p><b>END CAP CONFIGURATION</b></p> <p>- Mitered Mitered (default) MM</p> <p>- Open Open                OO</p> <p>- Mitered Open 0°          MO</p> <p>- Mitered Open 15°, 30°    MU</p> <p style="text-align: center;">↑</p>  <p>- Mitered Open 15°, 30°    MD</p> <p style="text-align: center;">↓</p>  <p><b>FASTENING</b></p> <p>- None (default)            N</p> <p>- Screw Holes                A</p> <p>- Spring Clips                B</p> <p>- Concealed Mounting      C</p> <p><b>FINISH</b></p> <p>- Appliance White (default) AW</p> <p>- Aluminum                  AL</p> <p>- Mill Finish                 MI</p> <p>- Brushed and Clear Coat Lacquer BC</p> <p>- Satin Anodized            SA</p> <p>- Special                      SP</p>
---	--

**B** LINEAR DIFFUSERS AND BAR GRILLES

**Notes:**

1. To use more than one "Accessory", list the items in order and specify description.
2. It is helpful to include a sketch for multiple units with mitered corners.

**SUGGESTED SPECIFICATION:**

Furnish and install **Nailor Model** (select one) **49-240** (1/2" (13) spacing, 1/4" (6) bar, 0° deflection); **49-241** (1/2" (13) spacing, 1/4" (6) bar, 15° deflection); **49-243** (1/2" (13) spacing, 1/4" (6) bar, 30° deflection); **49-280** (1/2" (13) spacing, 1/8" (3) bar, 0° deflection); **49-281** (1/2" (13) spacing, 1/8" (3) bar, 15° deflection); **49-480** (1/4" (6) spacing, 1/8" (3) bar, 0° deflection); **49-481** (1/4" (6) spacing, 1/8" (3) bar, 15° deflection) **Linear Bar Grilles** of the sizes and capacities as shown on the plans and air distribution schedules. The maximum length of a single section shall be 72" (1829) long. All sizes larger than 72" (1829) shall be provided in continuous multiple sections. Alignment strips are to be provided for joining continuous grille sections together. All frame types shall be extruded aluminum and include fastening as specified. A grille with a frame selection of A, B, C, D or E shall have a non-removable core that has fixed extruded aluminum bars and extruded aluminum cross bars that are spaced on a maximum of 12" (305) centers. A grille with a heavy duty floor frame selection of F, G or H shall have a removable core that attaches with core clips. The core shall have fixed extruded aluminum bars and extruded aluminum cross bars that are spaced on a maximum of 8" (203) centers. The finish is to be AW Appliance White baked enamel (optional finishes are available).

(Optional) A damper, constructed of heavy gauge corrosion-resistant steel and operable from the face of the grille, shall be provided on all units.

The manufacturer shall provide published performance data for the linear bar grille, which shall be tested in accordance with ANSI/ASHRAE Standard 70 – 1991.

## Performance Data

### Model 49-240 • 1/2" Spacing • 1/4" Bars • 0° Deflection

Free Area Square Feet Per Lineal Foot	Nominal Duct Width (Inches)	TP	.010	.022	.039	.062	.087	.119	.156	.198	.245
<b>.026</b>	<b>1-1/2</b>	CFM per Foot	<b>10</b>	<b>16</b>	<b>21</b>	<b>26</b>	<b>31</b>	<b>36</b>	<b>42</b>	<b>47</b>	<b>52</b>
		NC	—	—	13	19	24	30	34	37	40
		T Sill or Floor Side Wall	1-1-1 2-4-6	2-2-2 4-7-10	4-4-4 5-9-13	7-7-7 7-12-17	8-9-10 8-13-19	10-11-12 10-16-22	11-12-14 11-17-24	12-14-16 12-19-26	14-16-18 14-21-29
<b>.045</b>	<b>2</b>	CFM per Foot	<b>18</b>	<b>27</b>	<b>36</b>	<b>45</b>	<b>54</b>	<b>63</b>	<b>72</b>	<b>81</b>	<b>90</b>
		NC	—	—	12	18	23	29	33	36	39
		T Sill or Floor Side Wall	1-1-1 3-5-7	4-4-4 5-9-12	7-7-7 7-11-16	9-9-10 9-14-20	10-11-13 11-17-23	13-14-16 13-19-26	14-16-18 14-21-28	15-17-20 15-22-30	17-19-21 17-25-33
<b>.066</b>	<b>2-1/2</b>	CFM per Foot	<b>26</b>	<b>40</b>	<b>53</b>	<b>66</b>	<b>79</b>	<b>92</b>	<b>106</b>	<b>119</b>	<b>132</b>
		NC	—	—	14	20	26	31	35	38	41
		T Sill or Floor Side Wall	2-2-2 4-6-9	6-6-6 6-9-12	8-8-9 8-12-17	11-12-13 11-16-22	13-14-16 13-19-25	15-17-19 15-21-28	18-20-22 18-25-32	21-22-23 21-28-36	22-23-24 22-30-39
<b>.088</b>	<b>3</b>	CFM per Foot	<b>35</b>	<b>53</b>	<b>70</b>	<b>88</b>	<b>106</b>	<b>123</b>	<b>141</b>	<b>158</b>	<b>176</b>
		NC	—	—	15	21	27	32	36	39	42
		T Sill or Floor Side Wall	2-2-2 5-7-10	7-7-7 7-11-15	10-10-11 10-14-19	12-13-15 12-17-23	15-16-18 15-21-27	18-19-21 18-24-31	20-22-24 20-27-34	24-24-25 24-31-39	26-26-27 26-34-41
<b>.110</b>	<b>3-1/2</b>	CFM per Foot	<b>44</b>	<b>66</b>	<b>88</b>	<b>110</b>	<b>132</b>	<b>154</b>	<b>176</b>	<b>198</b>	<b>220</b>
		NC	—	—	16	22	28	33	37	40	43
		T Sill or Floor Side Wall	3-3-3 5-7-10	8-8-8 9-12-16	12-12-12 12-16-20	15-15-16 15-20-25	18-19-20 18-23-28	20-21-22 20-26-32	23-24-25 23-29-36	25-26-27 25-32-39	29-29-29 29-36-43
<b>.133</b>	<b>4</b>	CFM per Foot	<b>53</b>	<b>80</b>	<b>106</b>	<b>133</b>	<b>160</b>	<b>186</b>	<b>213</b>	<b>239</b>	<b>266</b>
		NC	—	—	17	23	29	34	38	41	44
		T Sill or Floor Side Wall	3-3-3 6-8-11	9-9-9 10-13-17	13-13-13 13-17-21	16-16-17 16-21-26	20-20-21 20-25-30	22-23-24 22-28-34	24-25-26 24-30-37	28-28-28 28-35-41	31-31-31 31-38-45
<b>.177</b>	<b>5</b>	CFM per Foot	<b>71</b>	<b>106</b>	<b>142</b>	<b>177</b>	<b>212</b>	<b>248</b>	<b>283</b>	<b>318</b>	<b>354</b>
		NC	—	10	18	24	30	35	39	42	45
		T Sill or Floor Side Wall	4-4-4 8-10-13	10-10-10 11-14-18	15-15-15 15-19-23	18-18-18 18-22-27	22-22-23 22-27-32	25-25-25 25-31-37	27-27-28 27-33-39	30-30-30 30-37-43	34-34-34 34-41-47
<b>.222</b>	<b>6</b>	CFM per Foot	<b>89</b>	<b>133</b>	<b>178</b>	<b>222</b>	<b>266</b>	<b>310</b>	<b>355</b>	<b>400</b>	<b>444</b>
		NC	—	11	20	25	31	36	40	43	46
		T Sill or Floor Side Wall	5-5-5 9-11-14	10-10-10 13-16-20	15-15-15 16-20-24	19-19-19 20-24-29	23-23-23 24-29-34	25-25-25 28-33-39	29-29-29 30-35-40	31-31-31 34-40-45	36-36-36 38-44-49

CFM - cubic feet per minute.

FPM - feet per minute velocity.

TP - total pressure - inches w.g.

T - throw in feet.

NC - Noise Criteria (values) based on 10 dB room absorption, re 10<sup>-12</sup> watts.

#### Performance Notes:

- Throws are given at 150, 100 and 50 fpm terminal velocities.
- Throw values are based on a 4 foot section with a cooling ΔT of 20°F (11°C). For other lengths, use the correction factor table above.
- NC values are based on a 10 foot active section. For other lengths, use the correction factor table above.

#### NC Correction for Length

Active Length, Ft.	1	2	4	8	10	15	20
Correction Factor	-10	-7	-4	-1	0	+2	+3

#### Throw Correction for Length

Active Length	Terminal Velocity		
	150 fpm	100 fpm	50 fpm
1 ft.	0.5	0.6	0.7
10 ft. +	1.6	1.4	1.2

- Return Air Applications:  
NC value is increased by + 4.  
Neg. SP = 0.8 x TP.

5. Data derived from tests conducted in accordance with ANSI/ASHRAE Standard 70 – 1991.

Nominal Width	Ak Factor per foot	
	Supply	Return
<b>1 1/2"</b>	.035	.030
<b>2"</b>	.054	.046
<b>2 1/2"</b>	.075	.064
<b>3"</b>	.098	.083
<b>3 1/2"</b>	.120	.102
<b>4"</b>	.143	.121
<b>5"</b>	.187	.159
<b>6"</b>	.233	.198

## Performance Data

### Model 49-241 • 1/2" Spacing • 1/4" Bars • 15° Deflection

Free Area Square Feet Per Lineal Foot	Nominal Duct Width (Inches)	TP	.012	.025	.047	.074	.105	.142	.187	.237	.294
.031	1-1/2	CFM per Foot	12	19	25	31	37	43	50	56	62
		NC	—	16	24	32	37	42	46	49	52
		T Sill or Floor Side Wall	1-1-1 2-4-6	3-3-3 4-7-10	5-5-5 6-10-14	7-7-7 7-12-17	9-9-10 9-14-20	10-11-12 10-16-23	12-13-15 12-18-25	13-15-17 13-20-27	14-16-18 14-22-30
.048	2	CFM per Foot	19	29	38	48	58	67	77	86	96
		NC	—	12	20	27	32	37	41	44	47
		T Sill or Floor Side Wall	1-1-1 3-5-7	4-4-4 5-8-12	7-7-7 7-11-16	9-9-10 9-14-20	11-12-13 11-17-24	13-14-15 13-19-26	15-16-18 15-22-29	16-18-20 16-23-31	17-19-22 17-25-34
.067	2-1/2	CFM per Foot	27	40	54	67	80	94	107	120	134
		NC	—	12	20	27	32	37	41	44	47
		T Sill or Floor Side Wall	1-1-1 4-6-8	5-5-5 6-9-13	9-9-9 9-13-17	11-11-12 11-16-21	13-14-15 14-19-25	15-16-18 15-21-27	17-19-21 17-24-31	20-21-22 20-27-35	22-22-23 22-29-38
.086	3	CFM per Foot	34	52	69	86	103	120	138	155	172
		NC	—	12	20	27	32	37	41	44	47
		T Sill or Floor Side Wall	2-2-2 4-6-9	6-6-6 8-11-15	10-10-11 10-14-19	12-13-14 13-18-23	15-16-18 16-21-27	18-19-20 18-24-31	20-21-23 21-28-35	23-24-25 23-30-38	25-25-25 26-34-41
.105	3-1/2	CFM per Foot	42	63	84	105	126	147	168	189	210
		NC	—	12	20	28	33	38	42	45	48
		T Sill or Floor Side Wall	2-2-2 6-8-11	8-8-8 9-12-16	11-11-12 12-16-21	15-15-15 14-19-24	17-18-19 18-23-29	21-21-22 21-27-33	22-23-25 23-29-36	25-25-26 25-32-39	28-28-29 28-36-43
.127	4	CFM per Foot	51	76	102	127	152	178	203	228	254
		NC	—	13	21	29	34	39	43	46	49
		T Sill or Floor Side Wall	3-3-3 6-9-12	9-9-9 10-13-17	13-13-13 13-17-22	16-16-17 15-20-25	19-20-21 19-24-30	22-22-23 22-28-34	24-25-26 25-31-38	27-27-27 28-36-41	30-30-30 30-37-44
.167	5	CFM per Foot	67	100	134	167	200	234	267	301	334
		NC	—	13	21	29	34	39	43	46	49
		T Sill or Floor Side Wall	4-4-4 8-11-14	10-10-10 11-15-19	14-14-14 15-19-24	18-18-18 19-23-28	21-21-22 21-26-32	24-24-25 24-30-36	26-27-28 26-32-39	30-30-30 29-36-42	32-32-32 33-39-46
.210	6	CFM per Foot	84	126	168	210	252	294	336	378	420
		NC	—	15	23	31	36	41	45	48	51
		T Sill or Floor Side Wall	5-5-5 9-12-15	10-10-10 14-17-21	15-15-15 17-21-25	19-19-19 20-24-29	23-23-23 24-29-34	25-25-25 27-32-38	28-28-29 29-35-40	31-31-31 32-38-43	35-35-35 36-42-47

CFM - cubic feet per minute.

FPM - feet per minute velocity.

TP - total pressure - inches w.g.

T - throw in feet.

NC - Noise Criteria (values) based on 10 dB room absorption, re 10<sup>-12</sup> watts.

#### Performance Notes:

- Throws are given at 150, 100 and 50 fpm terminal velocities.
- Throw values are based on a 4 foot section with a cooling ΔT of 20°F (11°C). For other lengths, use the correction factor table above.
- NC values are based on a 10 foot active section. For other lengths, use the correction factor table above.

#### NC Correction for Length

Active Length, Ft.	1	2	4	8	10	15	20
Correction Factor	-10	-7	-4	-1	0	+2	+3

#### Throw Correction for Length

Active Length	Terminal Velocity		
	150 fpm	100 fpm	50 fpm
1 ft.	0.5	0.6	0.7
10 ft. +	1.6	1.4	1.2

- Return Air Applications:  
NC value is increased by + 4.  
Neg. SP = 0.8 x TP.

5. Data derived from tests conducted in accordance with ANSI/ASHRAE Standard 70 – 1991.

Nominal Width	Ak Factor per foot	
	Supply	Return
1 1/2"	.041	.037
2"	.058	.051
2 1/2"	.076	.066
3"	.095	.080
3 1/2"	.115	.098
4"	.137	.113
5"	.177	.148
6"	.230	.189

B LINEAR DIFFUSERS AND BAR GRILLES

## Performance Data

### Model 49-243 • 1/2" Spacing • 1/4" Bars • 30° Deflection

Free Area Square Feet Per Lineal Foot	Nominal Duct Width (Inches)	TP	.012	.025	.047	.074	.105	.142	.187	.237	.294
.031	1-1/2	CFM per Foot	12	19	25	31	37	43	50	56	62
		NC	—	16	24	32	37	42	46	49	52
		T Sill or Floor Side Wall	1-1-1 2-4-6	3-3-3 4-7-10	5-5-5 6-10-14	7-7-7 7-12-17	9-9-10 9-14-20	10-11-12 10-16-23	12-13-15 12-18-25	13-15-17 13-20-27	14-16-18 14-22-30
.048	2	CFM per Foot	19	29	38	48	58	67	77	86	96
		NC	—	12	20	27	32	37	41	44	47
		T Sill or Floor Side Wall	1-1-1 3-5-7	4-4-4 5-8-12	7-7-7 7-11-16	9-9-10 9-14-20	11-12-13 11-17-24	13-14-15 13-19-26	15-16-18 15-22-29	16-18-20 16-23-31	17-19-22 17-25-34
.067	2-1/2	CFM per Foot	27	40	54	67	80	94	107	120	134
		NC	—	12	20	27	32	37	41	44	47
		T Sill or Floor Side Wall	1-1-1 4-6-8	5-5-5 6-9-13	9-9-9 9-13-17	11-11-12 11-16-21	13-14-15 14-19-25	15-16-18 15-21-27	17-19-21 17-24-31	20-21-22 20-27-35	22-22-23 22-29-38
.086	3	CFM per Foot	34	52	69	86	103	120	138	155	172
		NC	—	12	20	27	32	37	41	44	47
		T Sill or Floor Side Wall	2-2-2 4-6-9	6-6-6 8-11-15	10-10-11 10-14-19	12-13-14 13-18-23	15-16-18 16-21-27	18-19-20 18-24-31	20-21-23 21-28-35	23-24-25 23-30-38	25-25-25 26-34-41
.105	3-1/2	CFM per Foot	42	63	84	105	126	147	168	189	210
		NC	—	12	20	28	33	38	42	45	48
		T Sill or Floor Side Wall	2-2-2 6-8-11	8-8-8 9-12-16	11-11-12 12-16-21	15-15-15 14-19-24	17-18-19 18-23-29	21-21-22 21-27-33	22-23-25 23-29-36	25-25-26 25-32-39	28-28-29 28-36-43
.127	4	CFM per Foot	51	76	102	127	152	178	203	228	254
		NC	—	13	21	29	34	39	43	46	49
		T Sill or Floor Side Wall	3-3-3 6-9-12	9-9-9 10-13-17	13-13-13 13-17-22	16-16-17 15-20-25	19-20-21 19-24-30	22-22-23 22-28-34	24-25-26 25-31-38	27-27-27 28-36-41	30-30-30 30-37-44
.167	5	CFM per Foot	67	100	134	167	200	234	267	301	334
		NC	—	13	21	29	34	39	43	46	49
		T Sill or Floor Side Wall	4-4-4 8-11-14	10-10-10 11-15-19	14-14-14 15-19-24	18-18-18 19-23-28	21-21-22 21-26-32	24-24-25 24-30-36	26-27-28 26-32-39	30-30-30 29-36-42	32-32-32 33-39-46
.210	6	CFM per Foot	84	126	168	210	252	294	336	378	420
		NC	—	15	23	31	36	41	45	48	51
		T Sill or Floor Side Wall	5-5-5 9-12-15	10-10-10 14-17-21	15-15-15 17-21-25	19-19-19 20-24-29	23-23-23 24-29-34	25-25-25 27-32-38	28-28-29 29-35-40	31-31-31 32-38-43	35-35-35 36-42-47

CFM - cubic feet per minute.

FPM - feet per minute velocity.

TP - total pressure - inches w.g.

T - throw in feet.

NC - Noise Criteria (values) based on 10 dB room absorption, re 10<sup>-12</sup> watts.

#### Throw Correction for Length

Active Length	Terminal Velocity		
	150 fpm	100 fpm	50 fpm
1 ft.	0.5	0.6	0.7
10 ft. +	1.6	1.4	1.2

#### NC Correction for Length

Active Length, Ft.	1	2	4	8	10	15	20
Correction Factor	-10	-7	-4	-1	0	+2	+3

#### Performance Notes:

- Throws are given at 150, 100 and 50 fpm terminal velocities.
- Throw values are based on a 4 foot section with a cooling ΔT of 20°F (11°C). For other lengths, use the correction factor table above.
- NC values are based on a 10 foot active section. For other lengths, use the correction factor table above.

- Return Air Applications:  
NC value is increased by + 4.  
Neg. SP = 0.8 x TP.

- Data derived from tests conducted in accordance with ANSI/ASHRAE Standard 70 – 1991.

Nominal Width	Ak Factor per foot	
	Supply	Return
1 1/2"	.041	.037
2"	.058	.051
2 1/2"	.076	.066
3"	.095	.080
3 1/2"	.115	.098
4"	.137	.113
5"	.177	.148
6"	.230	.189

## Performance Data

### Model 49-280 • 1/2" Spacing • 1/8" Bars • 0° Deflection

Free Area Square Feet Per Lineal Foot	Nominal Duct Width (Inches)	TP	.009	.020	.035	.056	.078	.107	.140	.178	.220
.035	1-1/2	CFM per Foot	14	21	28	35	42	49	56	63	70
		NC	—	—	16	22	28	32	36	39	42
		T Sill or Floor Side Wall	1-1-1 2-4-6	2-2-2 4-7-10	4-4-4 6-7-13	7-7-7 7-12-17	8-9-10 8-13-19	10-11-12 10-16-22	11-12-14 11-17-24	12-14-17 12-19-26	13-15-18 13-21-29
.055	2	CFM per Foot	22	33	44	55	66	77	88	99	110
		NC	—	—	12	18	23	28	32	35	38
		T Sill or Floor Side Wall	1-1-1 3-5-7	4-4-4 5-8-12	7-7-7 7-11-16	9-9-10 9-14-20	11-11-12 11-17-23	13-14-16 13-19-26	14-16-18 14-21-28	15-17-20 15-22-30	17-19-21 17-25-33
.074	2-1/2	CFM per Foot	30	44	59	74	89	104	118	133	148
		NC	—	—	11	17	22	27	31	34	37
		T Sill or Floor Side Wall	1-1-1 4-6-8	5-5-5 6-9-13	9-9-9 9-13-17	11-11-12 11-16-21	13-14-15 13-18-24	15-16-17 15-21-28	18-19-20 17-24-31	20-21-23 20-27-35	23-24-25 23-31-39
.096	3	CFM per Foot	38	58	77	96	115	134	154	173	192
		NC	—	—	11	17	22	27	31	34	37
		T Sill or Floor Side Wall	2-2-2 5-7-10	7-7-7 7-10-14	10-10-11 10-14-19	12-13-14 12-17-23	15-16-17 15-20-26	18-19-20 18-24-30	20-21-23 20-27-34	23-24-25 23-30-38	25-25-26 25-33-41
.116	3-1/2	CFM per Foot	46	69	93	116	139	162	186	209	232
		NC	—	—	11	17	22	27	31	34	37
		T Sill or Floor Side Wall	3-3-3 5-7-10	8-8-8 9-12-16	12-12-12 12-16-20	15-15-16 15-20-25	18-19-20 18-23-28	20-21-23 20-26-32	23-24-25 23-29-36	25-26-27 25-32-39	29-29-29 29-36-43
.139	4	CFM per Foot	56	83	111	139	167	195	222	250	278
		NC	—	—	12	18	23	28	32	35	38
		T Sill or Floor Side Wall	3-3-3 6-8-11	9-9-9 10-13-17	13-13-13 13-17-21	16-16-17 16-20-25	20-20-21 20-25-30	23-23-24 22-28-34	24-25-26 24-30-37	27-27-27 28-35-41	30-30-30 31-38-44
.179	5	CFM per Foot	72	107	143	179	215	250	286	322	358
		NC	—	—	12	18	23	28	32	35	38
		T Sill or Floor Side Wall	4-4-4 8-10-13	10-10-10 11-14-18	14-14-14 15-19-23	18-18-18 18-22-27	22-22-23 22-27-32	24-24-24 24-30-36	27-27-28 27-33-39	30-30-31 30-37-43	32-32-32 34-41-47
.221	6	CFM per Foot	88	133	177	221	265	310	354	398	442
		NC	—	—	14	20	24	29	33	36	39
		T Sill or Floor Side Wall	5-5-5 9-12-15	10-10-10 13-16-20	15-15-15 16-20-24	18-18-18 20-24-29	23-23-23 24-29-34	25-25-25 28-33-39	28-28-28 30-35-40	31-31-31 34-40-45	32-32-32 38-44-49

**B** LINEAR DIFFUSERS AND BAR GRILLES

**CFM** - cubic feet per minute.

**FPM** - feet per minute velocity.

**TP** - total pressure - inches w.g.

**T** - throw in feet.

**NC** - Noise Criteria (values) based on 10 dB room absorption, re 10<sup>-12</sup> watts.

#### Throw Correction for Length

Active Length	Terminal Velocity		
	150 fpm	100 fpm	50 fpm
1 ft.	0.5	0.6	0.7
10 ft. +	1.6	1.4	1.2

#### NC Correction for Length

Active Length, Ft.	1	2	4	8	10	15	20
Correction Factor	-10	-7	-4	-1	0	+2	+3

#### Performance Notes:

1. Throws are given at 150, 100 and 50 fpm terminal velocities.

2. Throw values are based on a 4 foot section with a cooling ΔT of 20°F (11°C).

For other lengths, use the correction factor table above.

3. NC values are based on a 10 foot active section. For other lengths, use the correction factor table above.

4. Return Air Applications:

NC value is increased by + 4.

Neg. SP = 0.8 x TP.

5. Data derived from tests conducted in accordance with ANSI/ASHRAE Standard 70 – 1991.

Nominal Width	Ak Factor per foot	
	Supply	Return
1 1/2"	.047	.040
2"	.066	.055
2 1/2"	.084	.073
3"	.107	.089
3 1/2"	.127	.113
4"	.150	.127
5"	.190	.163
6"	.232	.197

## Performance Data

### Model 49-281 • 1/2" Spacing • 1/8" Bars • 15° Deflection

Free Area Square Feet Per Lineal Foot	Nominal Duct Width (Inches)	TP	.009	.020	.035	.056	.078	.107	.140	.178	.220
.039	1-1/2	CFM per Foot	16	23	31	39	47	55	62	70	78
		NC	—	18	27	33	38	43	47	50	53
		T Sill or Floor Side Wall	1-1-1 2-4-6	3-3-3 4-7-10	5-5-5 6-10-14	8-8-8 8-13-18	9-9-10 9-14-20	10-11-13 10-16-23	12-13-15 12-18-25	13-15-17 13-20-27	14-16-18 14-22-30
.056	2	CFM per Foot	22	34	45	56	67	78	90	101	112
		NC	—	12	20	26	31	36	40	44	47
		T Sill or Floor Side Wall	1-1-1 3-5-7	4-4-4 5-8-12	7-7-7 7-11-16	9-9-10 9-14-20	11-12-13 11-17-23	12-14-16 12-18-25	14-16-18 14-20-27	15-17-20 15-22-30	18-19-21 18-26-34
.075	2-1/2	CFM per Foot	30	45	60	75	90	105	120	135	150
		NC	—	10	18	24	30	35	39	43	46
		T Sill or Floor Side Wall	1-1-1 4-6-8	5-5-5 6-9-13	8-8-9 8-12-17	11-11-12 11-16-21	13-14-15 13-19-25	15-16-18 15-21-27	17-19-21 17-24-31	20-21-22 20-27-35	22-22-23 22-30-38
.093	3	CFM per Foot	37	56	74	93	112	130	149	167	186
		NC	—	—	17	23	29	34	38	42	45
		T Sill or Floor Side Wall	2-2-2 4-6-9	6-6-6 7-10-14	10-10-10 10-13-18	12-12-13 12-17-22	15-16-17 15-20-26	18-19-20 18-24-30	20-21-23 20-26-33	23-23-24 23-30-37	25-25-25 25-32-39
.113	3-1/2	CFM per Foot	45	68	90	113	136	158	181	203	226
		NC	—	—	17	23	29	34	38	42	45
		T Sill or Floor Side Wall	2-2-2 5-7-10	7-7-7 8-11-15	12-12-12 12-16-20	14-14-15 14-18-23	17-18-19 17-22-27	20-21-22 20-25-31	22-23-24 22-28-35	25-25-26 25-32-39	27-27-27 27-34-41
.133	4	CFM per Foot	53	80	106	133	160	186	212	239	266
		NC	—	10	18	24	30	35	39	43	46
		T Sill or Floor Side Wall	3-3-3 6-8-11	8-8-9 9-12-16	13-13-13 13-17-21	15-15-16 15-19-24	19-19-20 19-24-29	22-22-23 22-27-33	24-24-25 24-30-36	26-26-27 26-33-39	30-30-30 30-37-43
.173	5	CFM per Foot	69	104	138	173	208	242	277	312	346
		NC	—	10	18	24	30	35	39	43	46
		T Sill or Floor Side Wall	4-4-4 8-10-13	9-9-9 11-14-18	14-14-14 15-19-23	17-17-17 17-21-26	20-21-22 20-25-31	24-24-24 24-29-35	26-26-27 26-33-38	29-29-29 29-35-41	32-32-32 32-39-45
.212	6	CFM per Foot	85	127	170	212	254	296	339	382	424
		NC	—	10	18	24	30	35	39	43	46
		T Sill or Floor Side Wall	5-5-5 9-11-14	10-10-10 13-16-20	15-15-15 16-20-24	18-18-18 20-24-28	23-23-23 23-27-32	25-25-25 25-30-36	28-28-28 28-33-39	30-30-30 31-37-42	34-34-34 35-41-46

CFM - cubic feet per minute.

FPM - feet per minute velocity.

TP - total pressure - inches w.g.

T - throw in feet.

NC - Noise Criteria (values) based on 10 dB room absorption, re 10<sup>-12</sup> watts.

#### Performance Notes:

- Throws are given at 150, 100 and 50 fpm terminal velocities.
- Throw values are based on a 4 foot section with a cooling ΔT of 20°F (11°C). For other lengths, use the correction factor table above.
- NC values are based on a 10 foot active section. For other lengths, use the correction factor table above.

#### NC Correction for Length

Active Length, Ft.	1	2	4	8	10	15	20
Correction Factor	-10	-7	-4	-1	0	+2	+3

#### Throw Correction for Length

Active Length	Terminal Velocity		
	150 fpm	100 fpm	50 fpm
1 ft.	0.5	0.6	0.7
10 ft. +	1.6	1.4	1.2

- Return Air Applications:  
NC value is increased by + 4.  
Neg. SP = 0.8 x TP.

- Data derived from tests conducted in accordance with ANSI/ASHRAE Standard 70 – 1991.

Nominal Width	Ak Factor per foot	
	Supply	Return
1 1/2"	.052	.047
2"	.067	.060
2 1/2"	.086	.075
3"	.103	.091
3 1/2"	.123	.103
4"	.143	.126
5"	.183	.157
6"	.222	.188

## Performance Data

### Model 49-480 • 1/4" Spacing • 1/8" Bars • 0° Deflection

Free Area Square Feet Per Lineal Foot	Nominal Duct Width (Inches)	TP	.011	.024	.043	.068	.096	.130	.171	.218	.269
.031	1-1/2	CFM per Foot	12	19	25	31	37	43	50	56	62
		NC	—	—	14	20	24	29	33	36	39
		T Sill or Floor Side Wall	1-1-1 2-4-6	2-2-2 4-7-10	4-4-4 6-9-13	6-6-6 7-11-16	8-8-9 8-13-19	9-10-11 9-15-21	10-11-13 10-16-23	12-13-15 12-18-25	13-15-18 13-20-28
.047	2	CFM per Foot	19	28	37	47	56	66	75	84	94
		NC	—	—	12	18	23	29	32	36	39
		T Sill or Floor Side Wall	1-1-1 3-5-7	4-4-4 5-8-11	6-6-6 7-11-15	9-9-9 9-14-19	11-11-12 11-16-22	12-13-15 12-18-25	14-15-17 14-20-27	15-17-19 15-22-29	16-18-20 16-24-32
.065	2-1/2	CFM per Foot	26	39	52	65	78	91	104	117	130
		NC	—	—	14	20	24	30	34	37	40
		T Sill or Floor Side Wall	1-1-1 4-6-8	5-5-5 6-9-12	8-8-8 8-12-16	10-10-11 10-15-20	13-14-15 13-18-24	15-16-17 15-21-27	16-18-20 16-22-30	20-20-21 20-27-34	22-22-22 22-30-38
.083	3	CFM per Foot	33	50	66	83	100	116	133	149	166
		NC	—	—	14	20	26	31	35	38	41
		T Sill or Floor Side Wall	2-2-2 4-6-9	6-6-6 7-10-14	9-9-10 9-13-18	12-12-13 12-17-22	15-16-17 15-20-25	18-19-20 18-23-29	20-21-22 20-26-33	23-23-23 23-30-37	25-25-25 25-32-39
.102	3-1/2	CFM per Foot	41	61	82	102	122	143	163	184	204
		NC	—	—	15	21	27	32	36	39	42
		T Sill or Floor Side Wall	2-2-2 5-7-10	7-7-7 8-11-15	10-10-11 10-15-20	15-15-15 15-19-24	17-18-19 17-22-27	20-21-22 20-25-31	22-23-24 22-28-35	25-25-26 25-32-39	27-27-27 27-34-41
.122	4	CFM per Foot	49	73	98	122	146	171	195	220	244
		NC	—	—	16	22	29	33	37	40	43
		T Sill or Floor Side Wall	3-3-3 6-8-11	8-8-8 9-12-16	12-12-13 12-16-20	15-15-16 15-20-25	19-19-20 19-24-29	21-21-23 21-26-32	24-24-25 24-30-36	26-26-27 26-33-39	29-29-30 30-37-46
.157	5	CFM per Foot	63	94	125	157	188	220	251	282	314
		NC	—	—	16	22	28	33	37	40	43
		T Sill or Floor Side Wall	4-4-4 7-9-12	9-9-9 11-14-18	14-14-14 14-18-22	17-17-17 17-21-26	21-21-22 21-26-31	24-24-24 24-29-35	27-27-27 27-33-39	29-29-29 30-36-42	32-32-32 33-40-46
.194	6	CFM per Foot	78	116	155	194	233	272	310	349	388
		NC	—	10	18	24	30	35	38	42	43
		T Sill or Floor Side Wall	5-5-5 8-10-13	10-10-10 12-15-19	15-15-15 15-19-23	18-18-18 20-24-28	23-23-23 23-27-32	25-25-25 26-31-37	28-28-29 29-34-39	31-31-31 33-39-44	34-34-34 37-43-48

CFM - cubic feet per minute.

FPM - feet per minute velocity.

TP - total pressure - inches w.g.

T - throw in feet.

NC - Noise Criteria (values) based on 10 dB room absorption, re 10<sup>-12</sup> watts.

#### NC Correction for Length

Active Length, Ft.	1	2	4	8	10	15	20
Correction Factor	-10	-7	-4	-1	0	+2	+3

#### Throw Correction for Length

Active Length	Terminal Velocity		
	150 fpm	100 fpm	50 fpm
1 ft.	0.5	0.6	0.7
10 ft. +	1.6	1.4	1.2

#### Performance Notes:

- Throws are given at 150, 100 and 50 fpm terminal velocities.
- Throw values are based on a 4 foot section with a cooling ΔT of 20°F (11°C). For other lengths, use the correction factor table above.
- NC values are based on a 10 foot active section. For other lengths, use the correction factor table above.

#### 4. Return Air Applications:

- NC value is increased by + 4.
- Neg. SP = 0.8 x TP.

#### 5. Data derived from tests conducted in accordance with ANSI/ASHRAE Standard 70 – 1991.

Nominal Width	Ak Factor per foot	
	Supply	Return
1 1/2"	.041	.034
2"	.056	.048
2 1/2"	.074	.064
3"	.092	.078
3 1/2"	.111	.098
4"	.131	.111
5"	.166	.143
6"	.203	.173

## Performance Data

### Model 49-481 • 1/4" Spacing • 1/8" Bars • 15° Deflection

Free Area Square Feet Per Lineal Foot	Nominal Duct Width (Inches)	TP	.012	.026	.049	.077	.109	.148	.195	.247	.304
.034	1-1/2	CFM per Foot	14	20	27	34	41	48	54	61	68
		NC	—	14	22	30	35	39	43	46	49
		T Sill or Floor Side Wall	1-1-1 2-4-6	3-3-3 4-7-10	4-4-4 6-10-14	7-7-7 7-12-17	9-9-10 9-14-20	10-11-12 10-16-22	12-13-15 12-18-25	13-14-16 13-20-27	14-16-18 14-22-30
.049	2	CFM per Foot	20	29	39	49	59	69	78	88	98
		NC	—	12	20	27	32	37	41	44	47
		T Sill or Floor Side Wall	1-1-1 3-5-7	4-4-4 5-8-11	6-6-6 7-11-15	9-9-9 9-14-19	11-11-12 11-16-22	12-13-15 12-18-25	14-16-18 14-20-27	15-17-19 15-22-29	16-18-20 16-24-32
.065	2-1/2	CFM per Foot	26	39	52	65	78	91	104	117	130
		NC	—	12	20	27	32	37	41	44	47
		T Sill or Floor Side Wall	1-1-1 4-6-8	5-5-5 6-9-12	8-8-8 8-12-16	10-10-11 10-15-20	13-14-15 13-19-24	14-15-17 14-20-26	17-18-20 17-23-30	19-20-21 19-26-33	21-21-22 21-28-36
.082	3	CFM per Foot	33	49	66	82	98	115	131	148	164
		NC	—	12	20	27	32	37	41	44	47
		T Sill or Floor Side Wall	2-2-2 4-6-9	6-6-6 7-10-13	9-9-9 9-13-17	12-12-13 12-16-21	15-15-16 15-20-25	17-18-19 17-22-28	20-21-22 20-26-32	21-22-23 21-28-35	23-23-24 23-31-39
.099	3-1/2	CFM per Foot	40	59	79	99	119	138	158	178	198
		NC	—	12	20	28	33	37	41	44	47
		T Sill or Floor Side Wall	2-2-2 5-7-9	8-8-8 8-11-14	11-11-11 11-15-19	13-13-14 13-17-22	16-17-18 16-21-26	19-20-21 19-24-30	22-22-23 22-28-34	23-24-25 23-30-37	26-26-26 26-33-40
.117	4	CFM per Foot	47	70	94	117	140	164	187	220	234
		NC	—	13	21	28	34	38	42	45	48
		T Sill or Floor Side Wall	3-3-3 5-7-10	9-9-9 9-12-15	12-12-12 12-16-20	15-15-15 15-19-24	18-19-20 18-23-28	21-21-22 21-26-32	23-24-25 23-29-35	25-25-26 25-32-39	28-28-28 29-36-42
.152	5	CFM per Foot	61	91	121	152	182	212	243	274	304
		NC	—	14	22	29	34	39	43	46	49
		T Sill or Floor Side Wall	3-3-3 7-9-12	9-9-9 10-13-17	13-13-13 14-18-22	16-16-17 16-21-26	20-20-21 20-25-30	23-23-24 23-28-34	25-25-26 25-31-37	28-28-28 28-34-40	31-31-31 31-38-44
.186	6	CFM per Foot	74	111	149	186	223	260	298	335	372
		NC	—	14	22	30	35	40	43	47	50
		T Sill or Floor Side Wall	4-4-4 8-10-13	10-10-10 11-14-18	14-14-14 15-19-23	18-18-18 19-23-27	22-22-22 23-27-31	25-25-25 25-30-35	28-28-28 28-33-39	30-30-30 31-37-42	33-32-32 34-40-45

CFM - cubic feet per minute.

FPM - feet per minute velocity.

TP - total pressure - inches w.g.

T - throw in feet.

NC - Noise Criteria (values) based on 10 dB room absorption, re 10<sup>-12</sup> watts.

#### Performance Notes:

- Throws are given at 150, 100 and 50 fpm terminal velocities.
- Throw values are based on a 4 foot section with a cooling ΔT of 20°F (11°C). For other lengths, use the correction factor table above.
- NC values are based on a 10 foot active section. For other lengths, use the correction factor table above.

#### NC Correction for Length

Active Length, Ft.	1	2	4	8	10	15	20
Correction Factor	-10	-7	-4	-1	0	+2	+3

#### Throw Correction for Length

Active Length	Terminal Velocity		
	150 fpm	100 fpm	50 fpm
1 ft.	0.5	0.6	0.7
10 ft. +	1.6	1.4	1.2

- Return Air Applications:  
NC value is increased by + 4.  
Neg. SP = 0.8 x TP.

5. Data derived from tests conducted in accordance with ANSI/ASHRAE Standard 70 – 1991.

Nominal Width	Ak Factor per foot	
	Supply	Return
1 1/2"	.045	.041
2"	.059	.053
2 1/2"	.074	.065
3"	.091	.080
3 1/2"	.108	.091
4"	.126	.108
5"	.161	.138
6"	.195	.166