

## LAMINAR FLOW DIFFUSERS

- PROVEN TECHNOLOGY
- REMOVABLE PERFORATED FACE
- INTEGRAL VOLUME DAMPER

### Models:

- 92LFD-AL Aluminum
- 92LFD Steel
- 92LFD-SS Stainless Steel



The **Nailor 92LFD Series Laminar Flow Diffusers** utilize the well-proven and time-tested concept of vertical air mass 'laminar flow' technology. The **92LFD Series** produce a non-aspirating, low velocity, uniformly distributed downward moving 'piston' of conditioned air.

They may be used individually, or as in the case of hospital operating rooms, several units may be banked together to sufficiently cover the area and produce one large combined laminar mass. Installed in an operating room above the operating table, the clean conditioned air flows over and blankets the operating table, helping to protect and effectively isolate the patient from contaminated air. The only significant amount of room air entrainment occurs at the outer boundary of the laminar flow mass, outside the confines of the operating table. The patient is therefore bathed in 'clean air' and effectively isolated from secondary room air and any airborne contaminants.

The advantages of 'Laminar Flow' technology provide similar benefits in other 'cleanroom' applications such as research laboratories, animal laboratories, food processing plants and pharmaceutical laboratories.

The ability of the **92LFD Series** to maintain a sterile environment directly below is enhanced by the use of low level exhaust grilles located around the room periphery which remove the contaminated air before it can react with the boundary layer of the laminar flow mass.

A more recent application has been their use in computer rooms, where localized heavy cooling loads present a problem. The **92LFD Series**, when installed overhead, cools the load source directly, without creating objectionable high velocities in the occupied zone.

### FEATURES:

- Face plate is removable for cleaning and is secured by 1/4 turn fasteners.
- Safety cables are included as standard and prevent accidental dropping of the removable face.
- Integral backpan with round inlets.
- Perforated face has 3/32" (2.4) dia. holes on 60°, 1/4" (6) staggered centers (13% free area).
- Available in lay-in T-Bar and surface mount frame styles.
- Integral damper with screwdriver slot is easily accessed by removing face plug.

### Material:

**92LFD** - corrosion-resistant steel.

**92LFD-AL** - extruded aluminum frame, aluminum perforated face and corrosion-resistant steel backpan, deflector ring and damper (standard).

**Option:** AB Aluminum backpan, deflector ring and damper.

**92LFD-SS** - Type 304 stainless steel construction.

**Option:** 316 - Type 316 stainless steel construction.

**Finish:** Standard finish is AW Appliance White baked enamel on steel and aluminum models.

Standard finish on stainless steel models is #3 Satin Polished finish.

Other finishes are available.

## Dimensional Data

Models 92LFD-AL and 92LFD • Aluminum and Steel Laminar Flow Diffusers

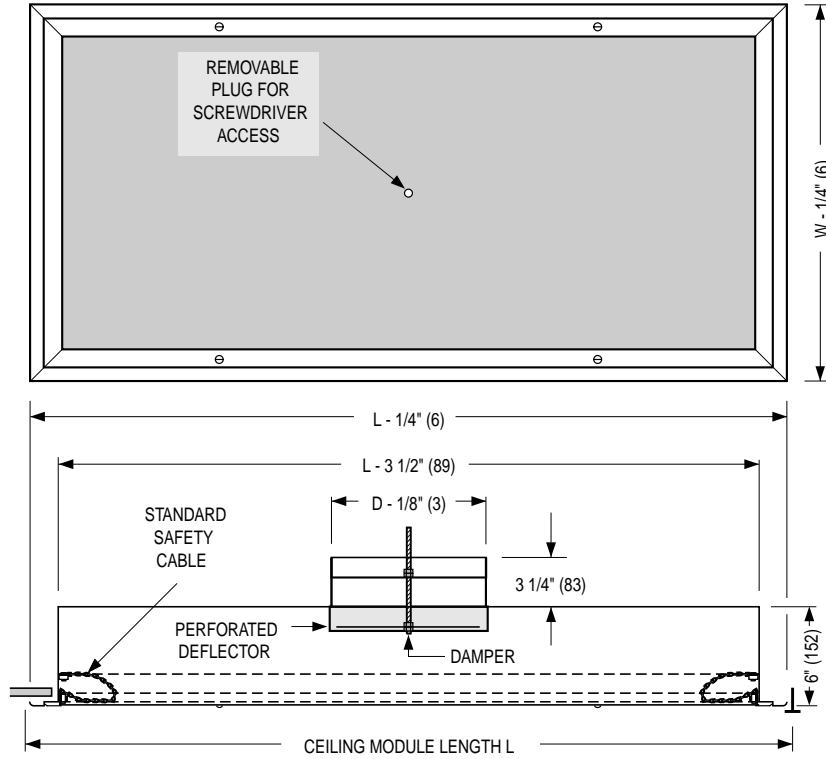

**Models 92LFD-AL, 92LFD**  
**Ceiling Module Sizes L x W & Nominal Round Duct Sizes D**

L x W	Imperial Modules (inches)	48 x 12	60 x 12	72 x 12	24 x 24	36 x 24	48 x 24	60 x 24	72 x 24
	Metric Modules (mm)	1200 x 300	1500 x 300	1800 x 300	600 x 600	900 x 600	1200 x 600	1500 x 600	1800 x 600
Duct Size D	(inches)	6, 7, 8	6, 7, 8	6, 7, 8	6, 7, 8	6, 7, 8 10, 12	7, 8, 10, 12	10, 12	10, 12
	(mm)	152, 178, 203	152, 178, 203	152, 178, 203	152, 178, 203	152, 178, 203 254, 305	178, 203, 254, 305	254, 305	254, 305

### Type S Surface Mount Detail

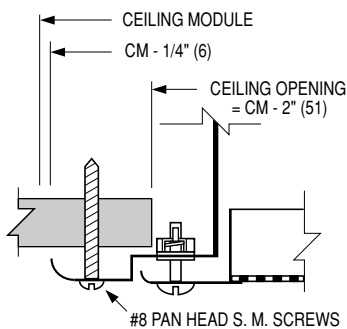

### Type L Lay-in T-Bar Detail

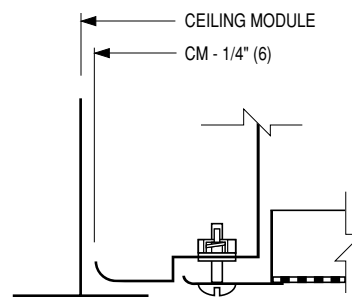

## Dimensional Data

### Model 92LFD-SS • Stainless Steel Laminar Flow Diffusers

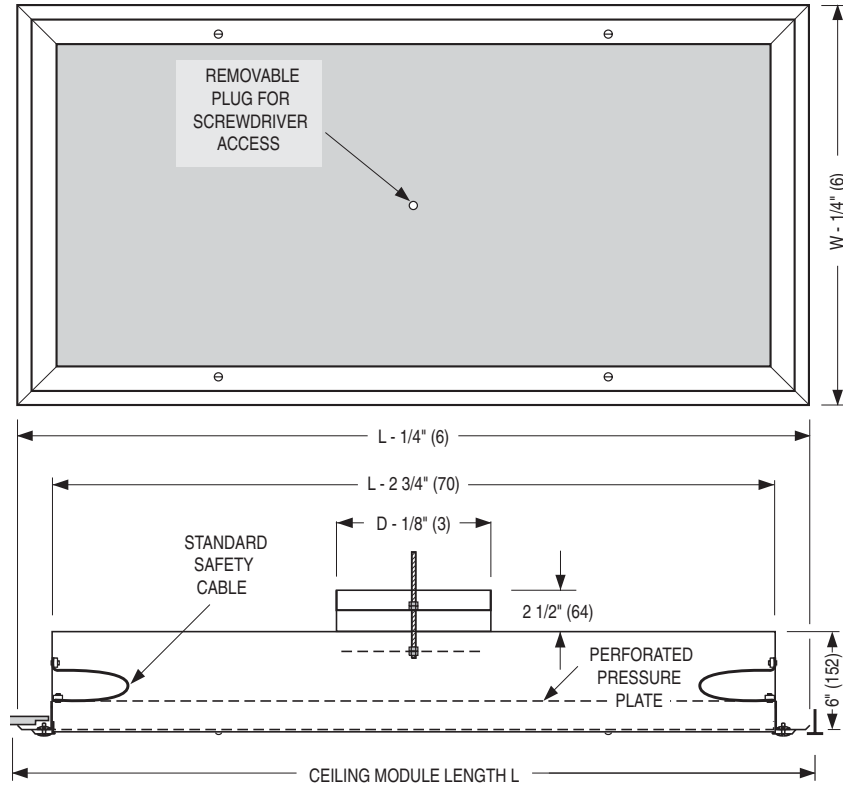

**Model 92LFD-SS**  
Ceiling Module Sizes L x W & Nominal Round Duct Sizes D

L x W	Imperial Modules (inches)		48 x 12	60 x 12	72 x 12	24 x 24	36 x 24	48 x 24	60 x 24	72 x 24
	Metric Modules (mm)		1200 x 300	1500 x 300	1800 x 300	600 x 600	900 x 600	1200 x 600	1500 x 600	1800 x 600
Duct Size D	(inches)		6, 7, 8	6, 7, 8	6, 7, 8	6, 7, 8	6, 7, 8 10, 12	7, 8, 10, 12	10, 12	10, 12
	(mm)		152, 178, 203	152, 178, 203	152, 178, 203	152, 178, 203	152, 178, 203 254, 305	178, 203, 254, 305	254, 305	254, 305

#### Type S Surface Mount Detail

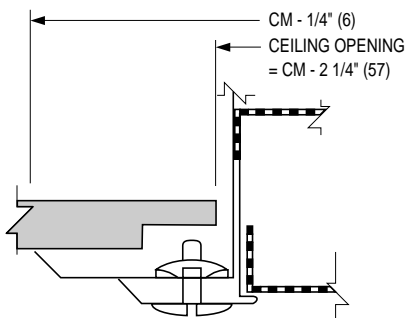

#### Type L Lay-in T-Bar Detail

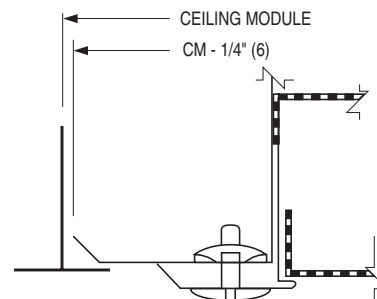

## HOW TO SPECIFY OR TO ORDER

(Show complete Model Number and Size, unless "Default" is desired).

### Aluminum and Steel Laminar Flow Diffusers – Model Series 92LFD

**92LFD-AL - 10 - 48 x 24 - L - AW - —**

#### MODEL

- Aluminum (with steel backpan) 92LFD-AL
- Steel 92LFD

#### INLET SIZE

06, 07, 08, 10, 12 (152, 178, 203, 254, 305)

#### CEILING MODULE SIZE

##### Imperial Modules (inches) (mm)

- 48 x 12 (1219 x 305)
- 60 x 12 (1524 x 305)
- 72 x 12 (1829 x 305)
- 24 x 24 (610 x 610)
- 36 x 24 (914 x 610)
- 48 x 24 (1219 x 610)
- 60 x 24 (1524 x 610)
- 72 x 24 (1829 x 610)

##### Metric Modules (mm)

- 1200 x 300
- 1500 x 300
- 1800 x 300
- 600 x 600
- 900 x 600
- 1200 x 600
- 1500 x 600
- 1800 x 600

#### OPTIONS

- None (default) —
- Aluminum Backpan, Deflector and Damper (92LFD-AL only) AB

#### FINISH

- Appliance White (default) AW
- Aluminum AL
- Special Custom Color SP
- Acrylic Appliance White AAW
- Acrylic Custom Color ASP

#### FRAME TYPE

- Lay-in T-Bar L
- Surface Mount S

E

HOSPITAL / CLEANROOM DIFFUSERS

#### Note:

1. Consult dimensional data as to limitations of model, module and neck size combinations.

#### SUGGESTED SPECIFICATION:

Furnish and install **Nailor Model** (select one) **92LFD-AL** (aluminum perforated face) or **Model 92LFD** (steel perforated face) **Laminar Flow Diffusers** of the sizes and capacities as shown on the plans and air distribution schedules. The diffusers shall have an extruded aluminum frame with a corrosion-resistant steel backpan and perforated inlet deflector ring. The perforated face of the diffuser shall have 13% free area with 3/32" (2.4) dia. holes on 1/4" (6) staggered centers. The face shall be attached with 1/4 turn fasteners to allow for complete removal and access to the interior for cleaning. All diffusers are to include safety cables to prevent accidental dropping of the removable face. A corrosion-resistant steel disc type damper, adjustable from the face of the diffuser, shall be provided with all units. The finish shall be AW Appliance White baked enamel (optional finishes are available).

The manufacturer shall provide published performance data for the diffuser, which shall be tested in accordance with ANSI/ASHRAE Standard 70 – 1991.

## HOW TO SPECIFY OR TO ORDER

(Show complete Model Number and Size, unless "Default" is desired).

### Stainless Steel Laminar Flow Diffusers – Model 92LFD-SS

**92LFD-SS - 10 - 48 x 24 - L - #3 - —**

**MODEL**

- 304 Stainless Steel      92LFD-SS

**INLET SIZE**

06, 07, 08, 10, 12 (152, 178, 203, 254, 305)

**CEILING MODULE SIZE**

**Imperial Modules (inches) (mm)**

- 48 x 12 (1219 x 305)
- 60 x 12 (1524 x 305)
- 72 x 12 (1829 x 305)
- 24 x 24 (610 x 610)
- 36 x 24 (914 x 610)
- 48 x 24 (1219 x 610)
- 60 x 24 (1524 x 610)
- 72 x 24 (1829 x 610)

**Metric Modules (mm)**

- 1200 x 300
- 1500 x 300
- 1800 x 300
- 600 x 600
- 900 x 600
- 1200 x 600
- 1500 x 600
- 1800 x 600

**OPTIONS**

- None (default)      —
- 316 Stainless Steel Construction      316

**FINISH**

- #3 Satin Polished (default)      #3
- Appliance White      AW
- Special Custom Color      SP

**FRAME TYPE**

- Lay-in T-Bar      L
- Surface Mount      S



HOSPITAL / CLEANROOM DIFFUSERS

**Note:**

1. Consult dimensional data as to limitations of model, module and neck size combinations.

**SUGGESTED SPECIFICATION:**

Furnish and install **Nailor Model 92LFD-SS Laminar Flow Diffusers** of the sizes and capacities as shown on the plans and air distribution schedules. The diffusers shall be constructed entirely from 304 stainless steel (316 optional), minimum 24 gauge. The perforated face of the diffuser shall have 13% free area with 3/32" (2.4) dia. holes on 1/4" (6) staggered centers. The face shall incorporate a second pressure plate as an integral assembly to ensure true laminar airflow. The face shall be attached with 1/4 turn fasteners to allow for complete removal and access to the interior for cleaning. All diffusers are to include safety cables to prevent accidental dropping of the removable face. A disc type damper, adjustable from the face of the diffuser, shall be provided with all units. Integral earthquake hanger tabs shall be included with all units. All exposed surfaces shall have a #3 satin polished finish (optional finishes are available).

The manufacturer shall provide published performance data for the diffuser, which shall be tested in accordance with ANSI/ASHRAE Standard 70 – 1991.

## Performance Data

Models 92LFD-AL, 92LFD, 92LFD-SS

### Imperial Units

8" (203 mm) dia. Inlet

Module Size	Airflow, CFM	100	120	140	160	180	200	220	240	260	280	300
48" x 12" or 1200 mm x 300 mm	Total Pressure	.030	.043	.058	.076	.096	.119	.144	.172	.201	.233	.268
	NC	—	17	19	22	25	27	29	31	34	35	37
	Throw	.5-1-2	.5-1-3	1-1.5-4	1.5-2-4	1.5-2.5-5	2-3.5-5	2.5-4-6	3-4.5-7	3-4.5-7.5	4-5.5-8	4.5-6-9
60" x 12" or 1500 mm x 300 mm	Total Pressure	.028	.040	.055	.072	.091	.112	.136	.161	.189	.220	.252
	NC	—	16	18	21	24	25	28	30	33	34	36
	Throw	.5-1-2	1-1-3	1-1.5-4	1-2-4	1-2.5-4.5	2-3.5-5	2-4-5.5	3-4-6.5	3-5-7	4-5-8	4-6-8.5
72" x 12" or 1800 mm x 300 mm	Total Pressure	.026	.037	.050	.066	.083	.103	.125	.148	.174	.202	.232
	NC	—	16	18	21	23	26	27	30	32	33	35
	Throw	.5-1-2	1-1-3	1-1.5-4	1-2-4	1-2.5-4.5	2-3.5-5	2-4.5-5	3-4-6.5	3-4.5-7	4-5-8	4-6-8.5

Module Size	Airflow, CFM	100	120	140	160	180	200	220	240	260	280	300
24" x 24" or 600 mm x 600 mm	Total Pressure	.030	.043	.058	.076	.096	.119	.144	.172	.201	.233	.268
	NC	—	17	19	22	25	27	29	31	34	35	37
	Throw	.5-1-2	.5-1-3	1-1.5-4	1.5-2-4	1.5-2.5-5	2-3.5-6	2.5-4-6	3-4.5-7	3-4.5-7.5	4-5.5-8	4.5-6-9
36" x 24" or 900 mm x 600 mm	Total Pressure	.026	.037	.050	.066	.083	.103	.125	.148	.174	.202	.232
	NC	—	15	18	21	24	26	28	30	33	34	36
	Throw	0-1-1.5	0-1-2	0-1-3	1-2-3.5	1-2-4.5	2-3-5	2-3-5.5	2-3.5-6	2.5-4.5-7	3-5-8	3-5-8
48" x 24" or 1200 mm x 600 mm	Total Pressure	.023	.034	.046	.060	.075	.093	.113	.134	.158	.183	.210
	NC	—	—	17	20	23	25	27	30	32	33	35
	Throw	0-5-1.5	.5-1-2	.5-1-2.5	1-1.5-3	1-2-4	1-2-5	1.5-2.5-5	2-3-6	2-4-6.5	2-4.5-7	3-5-7

10" (254 mm) dia. Inlet

Module Size	Airflow, CFM	160	180	200	220	240	260	280	300	320	340	360
48" x 24" or 1200 mm x 600 mm	Total Pressure	.022	.028	.035	.042	.050	.059	.069	.079	.090	.113	.140
	NC	—	15	18	19	22	25	27	29	31	33	35
	Throw	1-1-3	1-2-4	1-2-5	1.5-2.5-5	2-3-6	2-4-6.5	2-4.5-7	3-5-7	3-5-8	4-6-8.5	5-7-9
60" x 24" or 1500 mm x 600 mm	Total Pressure	.021	.027	.033	.040	.048	.056	.065	.074	.084	.107	.132
	NC	—	—	17	19	22	24	27	29	31	33	35
	Throw	1-1-3	1-2-4	1-2-5	1.5-2.5-5	2-3-6	2-4-6.5	2-4.5-7	3-5-7	3-5-8	4-6-8.5	5-7-9
72" x 24" or 1800 mm x 600 mm	Total Pressure	.021	.027	.033	.036	.043	.050	.058	.066	.076	.096	.118
	NC	—	—	17	19	22	24	27	29	31	32	34
	Throw	1-1-3	1-1-4	1-2-4.5	1-2-5	1.5-2.5-6	2-3-6	2-4-7	2.5-4-7	3-4.5-7.5	3.5-5-8	4.5-6-9

12" (305 mm) dia. Inlet

Module Size	Airflow, CFM	230	260	290	315	345	375	400	430	460	490	520
48" x 24" or 1200 mm x 600 mm	Total Pressure	.036	.046	.057	.068	.081	.096	.109	.126	.144	.163	.184
	NC	15	18	21	22	25	28	30	32	35	38	42
	Throw	1-2-6	1.5-3-6.5	2-4-7	3-5-8	4-5.5-8	4.5-6-8.5	5-7-9.5	5.5-7.5-10	6-8-11	6.5-8.5-11.5	7-9-12
60" x 24" or 1500 mm x 600 mm	Total Pressure	.031	.040	.049	.058	.070	.083	.094	.108	.124	.141	.159
	NC	15	18	21	22	25	28	30	32	35	38	42
	Throw	1-2-6	2-3-6	2-4-7	3-5-8	4-5.5-7.5	4.5-6-8.5	5-6.5-9	5.5-7.5-9.5	6-8-10.5	6-8.5-11	6.5-8.5-11.5
72" x 24" or 1800 mm x 600 mm	Total Pressure	.028	.036	.045	.053	.063	.075	.085	.099	.113	.128	.144
	NC	14	17	20	21	24	27	29	31	34	37	41
	Throw	1-2-5	1.5-2.5-6	2-4-6.5	3-4.5-7	4-5-7	4-5.5-8	5-6-8.5	5-7-9	5.5-7.5-10	6-8-10.5	6-8-11

CFM - cubic feet per minute

FPM - feet per minute velocity

TP - total pressure - inches w.g.

T - throw in feet

NC - Noise Criteria (values) based on 10 dB room absorption, re 10<sup>-12</sup> watts. Damper fully open.

### Performance Notes:

1. Throws are the average vertical distance in feet to terminal velocities of 100, 75 and 50 fpm. Based upon a cooling ΔT of 10°F. 9 ft. ceiling.
2. Data derived from tests conducted in accordance with ANSI/ASHRAE Standard 70 – 1991.

## Performance Data

### Models 92LFD-AL, 92LFD, 92LFD-SS

#### Metric Units

#### 8" (203 mm) dia. Inlet

Module Size	Airflow, L/S	47	57	66	76	85	94	104	113	123	132	142
1219 mm x 305 mm or	Total Pressure	7	11	14	19	24	30	36	43	50	58	67
	NC	—	17	19	22	25	27	29	31	34	35	37
1200 mm x 300 mm	Throw	0.2-0.3-0.6	0.2-0.3-0.9	0.3-0.5-1.2	0.5-0.6-1.2	0.5-0.8-1.5	0.6-1.1-1.5	0.8-1.2-1.8	0.9-1.4-2.1	0.9-1.4-2.3	1.2-1.7-2.4	1.4-1.8-2.7
1524 mm x 305 mm or	Total Pressure	7	10	14	18	23	28	34	40	47	55	63
	NC	—	16	18	21	24	25	28	30	33	34	36
1500 mm x 300 mm	Throw	0.2-0.3-0.6	0.3-0.3-0.9	0.3-0.5-1.2	0.3-0.6-1.2	0.3-0.8-1.4	0.6-1.1-1.5	0.6-1.2-1.7	0.9-1.2-2.0	0.9-1.5-2.1	1.2-1.5-2.4	1.2-1.8-2.6
1829 mm x 305 mm or	Total Pressure	6	9	12	16	21	26	31	37	43	50	58
	NC	—	16	18	21	23	26	27	30	32	33	35
1800 mm x 300 mm	Throw	0.2-0.3-0.6	0.3-0.3-0.9	0.3-0.5-1.2	0.3-0.6-1.2	0.3-0.8-1.4	0.6-1.1-1.5	0.6-1.4-1.5	0.9-1.2-2.0	0.9-1.4-2.1	1.2-1.5-2.4	1.2-1.8-2.6

Module Size	Airflow, L/S	47	57	66	76	85	94	104	113	123	132	142
610 mm x 610 mm or	Total Pressure	7	11	14	19	24	30	36	43	50	58	67
	NC	—	17	19	22	25	27	29	31	34	35	37
600 mm x 600 mm	Throw	0.2-0.3-0.6	0.2-0.3-0.9	0.3-0.5-1.2	0.5-0.6-1.2	0.5-0.8-1.5	0.6-1.1-1.8	0.8-1.2-1.8	0.9-1.4-2.1	0.9-1.4-2.3	1.2-1.7-2.4	1.4-1.8-2.7
914 mm x 610 mm or	Total Pressure	6	9	12	16	21	26	31	37	43	50	58
	NC	—	15	18	21	24	26	28	30	33	34	36
900 mm x 600 mm	Throw	0-0.3-0.5	0-0.3-0.6	0-0.3-0.9	0.3-0.6-1.1	0.3-0.6-1.4	0.6-0.9-1.5	0.6-0.9-1.7	0.6-1.1-1.8	0.8-1.4-2.1	0.9-1.5-2.4	0.9-1.5-2.4
1219 mm x 610 mm or	Total Pressure	6	8	11	15	19	23	28	33	39	45	52
	NC	—	—	17	20	23	25	27	30	32	33	35
1200 mm x 600 mm	Throw	0-0.2-0.5	0.2-0.3-0.6	0.2-0.3-0.8	0.3-0.5-0.9	0.3-0.6-1.2	0.3-0.6-1.5	0.5-0.8-1.5	0.6-0.9-1.8	0.6-1.2-2.0	0.6-1.4-2.1	0.9-1.5-2.1

#### 10" (254 mm) dia. Inlet

Module Size	Airflow, L/S	76	85	94	104	113	123	132	142	151	160	170
1219 mm x 610 mm or	Total Pressure	5	7	9	10	12	15	17	20	22	28	35
	NC	—	15	18	19	22	25	27	29	31	33	35
1200 mm x 600 mm	Throw	0.3-0.3-0.9	0.3-0.6-1.2	0.3-0.6-1.5	0.5-0.8-1.5	0.6-0.9-1.8	0.6-1.2-2.0	0.6-1.4-2.1	0.9-1.5-2.1	0.9-1.5-2.4	1.2-1.8-2.6	1.5-2.1-2.7
1524 mm x 610 mm or	Total Pressure	5	7	8	10	12	14	16	18	21	27	33
	NC	—	—	17	19	22	24	27	29	31	33	35
1500 mm x 600 mm	Throw	0.3-0.3-0.9	0.3-0.6-1.2	0.3-0.6-1.5	0.5-0.8-1.5	0.6-0.9-1.8	0.6-1.2-2.0	0.6-1.4-2.1	0.9-1.5-2.1	0.9-1.5-2.4	1.2-1.8-2.6	1.5-2.1-2.7
1829 mm x 610 mm or	Total Pressure	5	7	8	9	11	12	14	16	19	24	29
	NC	—	—	17	19	22	24	27	29	31	32	34
1800 mm x 600 mm	Throw	0.3-0.3-0.9	0.3-0.3-1.2	0.3-0.6-1.4	0.3-0.6-1.5	0.5-0.8-1.8	0.6-0.9-1.8	0.6-1.2-2.1	0.8-1.2-2.1	0.9-1.4-2.3	1.1-1.5-2.4	1.4-1.8-2.7

#### 12" (305 mm) dia. Inlet

Module Size	Airflow, L/S	109	123	137	149	163	177	189	203	217	231	245
1219 mm x 610 mm or	Total Pressure	9	11	14	17	20	24	27	31	36	41	46
	NC	15	18	21	22	25	28	30	32	35	38	42
1200 mm x 600 mm	Throw	0.3-0.6-1.8	0.5-0.9-2.0	0.6-1.2-2.1	0.9-1.5-2.4	1.2-1.7-2.4	1.4-1.8-2.6	1.5-2.1-2.9	1.7-2.3-3.0	1.8-2.4-3.4	2.0-2.6-3.5	2.1-2.7-3.7
1524 mm x 610 mm or	Total Pressure	8	10	12	14	17	21	23	27	31	35	40
	NC	15	18	21	22	25	28	30	32	35	38	42
1500 mm x 600 mm	Throw	0.3-0.6-1.8	0.6-0.9-1.8	0.6-1.2-2.1	0.9-1.5-2.4	1.2-1.7-2.3	1.4-1.8-2.6	1.5-2.0-2.7	1.7-2.3-2.9	1.8-2.4-3.2	1.8-2.6-3.4	2.0-2.6-3.5
1829 mm x 610 mm or	Total Pressure	7	9	11	13	16	19	21	25	28	32	36
	NC	14	17	20	21	24	27	29	31	34	37	41
1800 mm x 600 mm	Throw	0.3-0.6-1.5	0.5-0.8-1.8	0.6-1.2-2.0	0.9-1.4-2.1	1.2-1.5-2.1	1.2-1.7-2.4	1.5-1.8-2.6	1.5-2.1-2.7	1.7-2.3-3.0	1.8-2.4-3.2	1.8-2.4-3.4

L/S - litres per second

M/S - meters per second velocity

TP - total pressure - Pa

T - throw in meters

NC - Noise Criteria (values) based on 10 dB room absorption, re 10<sup>-12</sup> watts. Damper fully open.

#### Performance Notes:

1. Throws are the average vertical distance in meters to terminal velocities of 0.51, 0.38 and 0.25 m/s. Based upon a cooling ΔT of 5.5°C. 2.7 m ceiling.

2. Data derived from tests conducted in accordance with ANSI/ASHRAE Standard 70 – 1991.

## LAMINAR FLOW DIFFUSERS WITH FILTERS

- PROVEN TECHNOLOGY
- HEPA OR ULPA FILTERS
- REMOVABLE PERFORATED FACE
- INTEGRAL VOLUME DAMPER
- UNIDIRECTIONAL AIRFLOW

### Models:

**92LFDF-AL Aluminum with Filter**

**92LFDF-SS Stainless Steel with Filter**



Model 92LFDF-SS

The **Nailor 92LFDF Series Laminar Flow Diffusers with Filters** utilize the well-proven and time-tested concept of vertical air mass 'laminar flow' technology. The **92LFDF Series** produce a non-aspirating, low velocity, uniformly distributed downward moving 'piston' of conditioned air. They are designed with an integral 'knife-edge' frame to accommodate a Gel Seal HEPA or ULPA filter. The filters can be easily removed and replaced from the face of the unit. These high quality filters incorporate a separatorless 2" (51) deep media, integral test port and an anodized aluminum gel seal frame.

They may be used individually, or as in the case of hospital operating rooms, several units may be banked together to sufficiently cover the area and produce one large combined laminar mass. Installed in an operating room above the operating table, the clean conditioned air flows over and blankets the operating table, helping to protect and effectively isolate the patient from contaminated air. The only significant amount of room air entrainment occurs at the outer boundary of the laminar flow mass, outside the confines of the operating table. The patient is therefore bathed in 'clean air' and effectively isolated from secondary room air and any airborne contaminants.

The advantages of 'Laminar Flow' technology provide similar benefits in other 'cleanroom' applications such as research laboratories, bio-technology facilities, animal laboratories, food processing plants, semi-conductor manufacturing, pharmaceutical laboratories and protective environment rooms.

The ability of the **92LFDF Series** to maintain a sterile environment directly below is enhanced by the use of low level exhaust grilles located around the room periphery which remove the contaminated air before it can react with the boundary layer of the laminar flow mass.

### FEATURES:

- Face plate is removable for cleaning and is secured by 1/4 turn fasteners.
- Safety cables are included as standard and prevent accidental dropping of the removable face.
- Perforated face has 3/32" (2.4) dia. holes on 60°, 1/4" (6) staggered centers (13% free area).
- Round inlets for simple duct connection.
- Standard unit designed for both lay-in T-Bar ceiling systems and surface mount applications.
- Integral 'knife-edge' frame accommodates Gel Seal HEPA or ULPA filters.
- Clear anodized extruded aluminum filter frame with a removable test port for damper adjustment, filter pressure drop measurement or to perform leakage (scan) tests.
- HEPA Filter (99.99% on 0.3 µm) is supplied as standard.
- Filters are packaged independently from the diffuser for final installation in the field (by others).
- Integral damper with screwdriver slot adjustment is easily accessed.

### Material:

**92LFDF-AL** - Extruded aluminum frame, aluminum perforated face, backpan, deflector ring and damper.

**92LFDF-SS** - Type 304 Stainless Steel construction.

### Options:

- 316 Stainless Steel construction.
- UL ULPA Filter (99.9995% on 0.12 µm).

**Finish:** Standard finish for **Model 92LFDF-AL** is AW Appliance White. The standard finish for **Model 92LFDF-SS** is #3 Satin Polished. Other finishes are available.

## Dimensional Data

### Model 92LFDF-AL • Aluminum Laminar Flow Diffuser with Filter

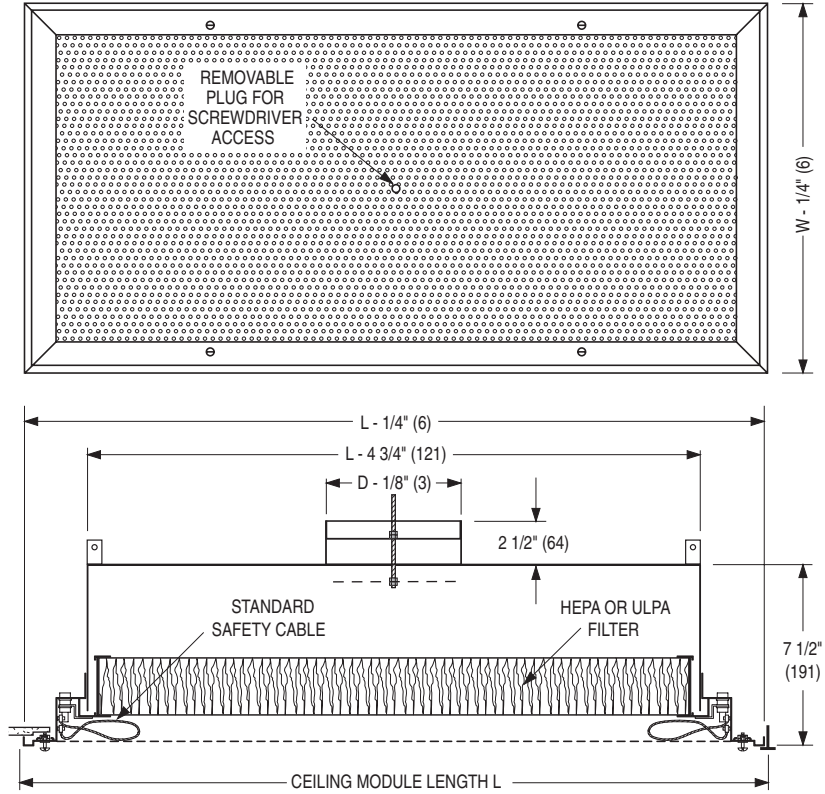

**Ceiling Module Sizes L x W & Nominal Round Duct Sizes D**

L x W	Imperial Modules (inches)	48 x 12	60 x 12	24 x 24	36 x 24	48 x 24	60 x 24
	Metric Modules (mm)	1200 x 300	1500 x 300	600 x 600	900 x 600	1200 x 600	1500 x 600
Duct Size D	(inches)	6, 7, 8	6, 7, 8	6, 7, 8	6, 7, 8, 10	7, 8, 10, 12	10, 12
	(mm)	152, 178, 203	152, 178, 203	152, 178, 203	152, 178, 203, 254	178, 203, 254, 305	254, 305

**Type S Surface Mount Detail**

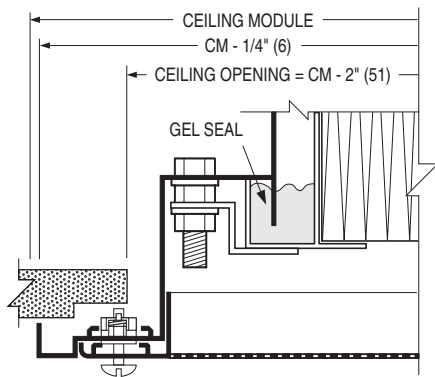

**Type L Lay-in T-Bar Detail**

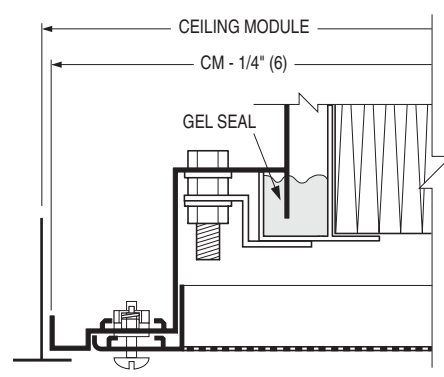

## Dimensional Data

### Model 92LFDF-SS • Stainless Steel Laminar Flow Diffuser with Filter

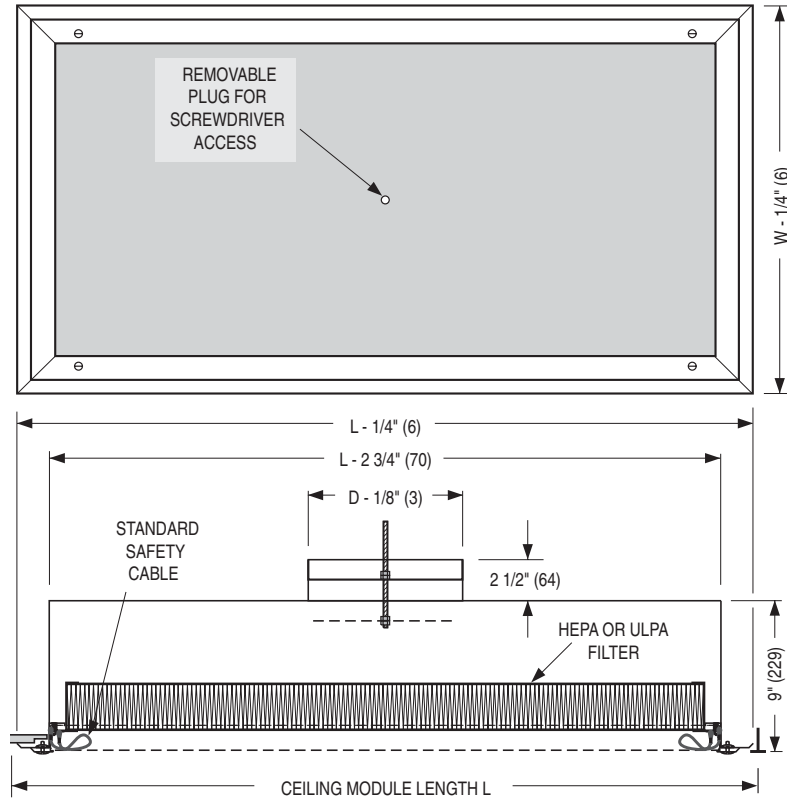

**Ceiling Module Sizes L x W & Nominal Round Duct Sizes D**

L x W	Imperial Modules (inches)	48 x 12	60 x 12	24 x 24	36 x 24	48 x 24	60 x 24
	Metric Modules (mm)	1200 x 300	1500 x 300	600 x 600	900 x 600	1200 x 600	1500 x 600
Duct Size D	(inches)	6, 7, 8	6, 7, 8	6, 7, 8	6, 7, 8, 10	7, 8, 10, 12	10, 12
	(mm)	152, 178, 203	152, 178, 203	152, 178, 203	152, 178, 203, 254	178, 203, 254, 305	254, 305

**Type S Surface Mount Detail**

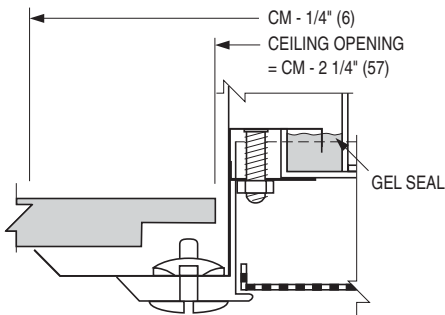

**Type L Lay-in T-Bar Detail**

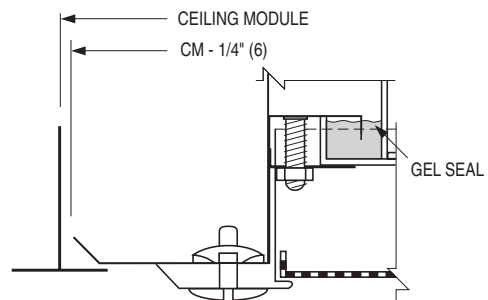

**E**

HOSPITAL / CLEANROOM DIFFUSERS

## HOW TO SPECIFY OR TO ORDER

(Show complete Model Number and Size, unless "Default" is desired).

### Aluminum Laminar Flow Diffuser with Filter – Model 92LFDF-AL

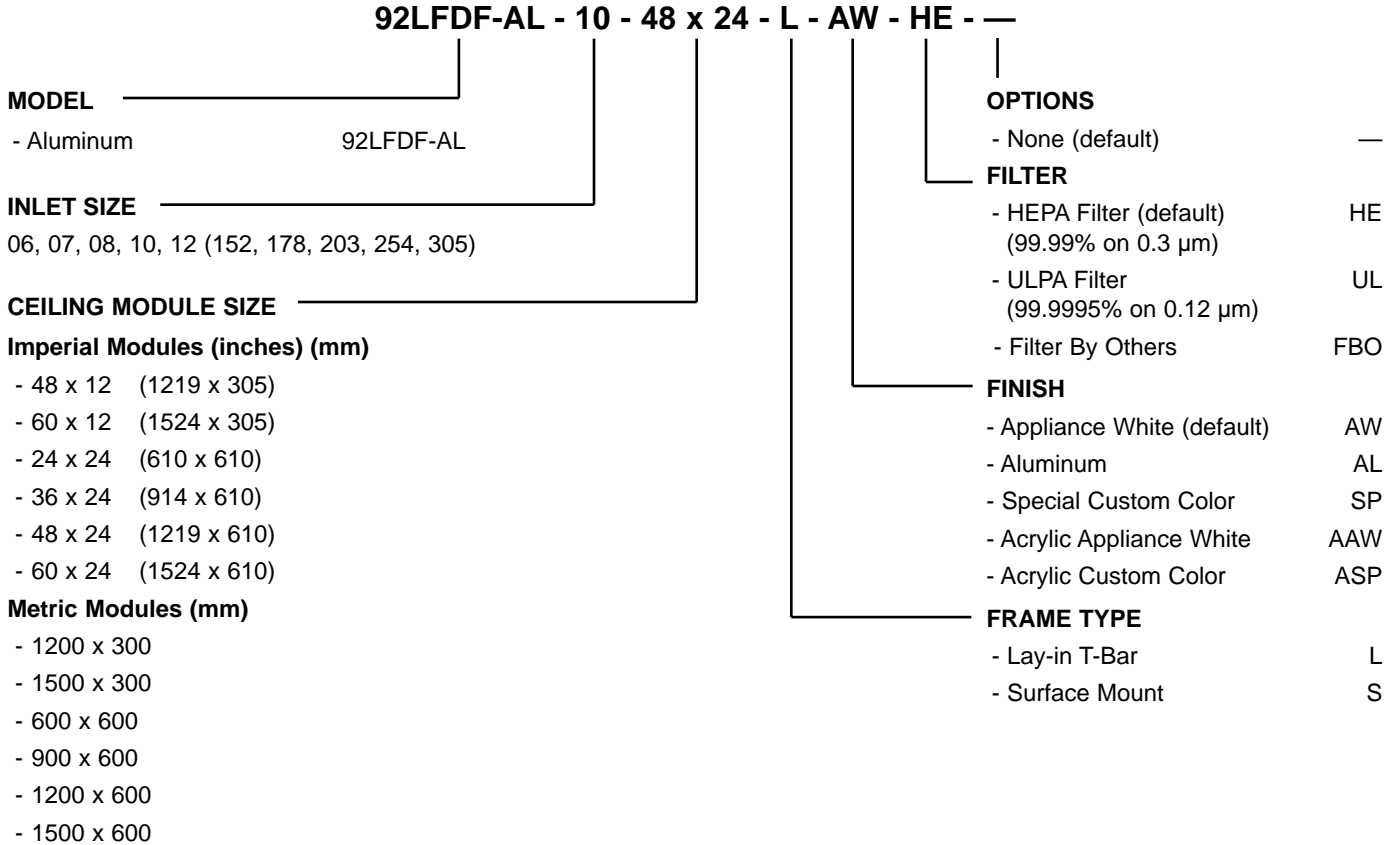

**HOSPITAL / CLEANROOM DIFFUSERS**

**Note:**

1. Consult dimensional data as to limitations of model, module and neck size combinations.

**SUGGESTED SPECIFICATION:**

Furnish and install **Nailor Model 92LFDF-AL Laminar Flow Diffusers with Filters** of the sizes and capacities as shown on the plans and air distribution schedules. The diffusers shall have an aluminum backpan, a perforated inlet deflector ring, a disc type damper and an extruded aluminum frame. The face of the diffuser shall be perforated aluminum and have a 13% free area with 3/32" (2.4) dia. holes on 1/4" (6) staggered centers. The face shall be attached with 1/4 turn fasteners to allow for complete removal and access to the interior for cleaning. All diffusers are to include safety cables to prevent accidental dropping of the removable face. The finish shall be AW Appliance White baked enamel (optional finishes are available).

The diffuser plenum shall incorporate an integral filter frame to accommodate a Gel Seal filter. Filters shall be securely held in place by at least four mounting brackets allowing filter removal from the face of the diffuser without disturbing installed ductwork or the diffuser mounting surface. Filters shall incorporate a removable test port, to measure filter pressure drop, perform leakage (scan) tests and to adjust the balancing damper without removing the filter. The filters efficiency shall be HEPA: 99.99% minimum removal efficiency on 0.30 micrometer particle size (ULPA: 99.9995% minimum removal efficiency on 0.12 micrometer particle size optional). Filters shall incorporate an anodized extruded aluminum frame and a 2" (51) deep separatorless filter pack. All filters shall be UL 900 Class I Listed and Factory Mutual Approved. All filters shall be individually scan tested per Section 6.2 of IEST-RP-CC034.1. Filters are to be packaged independently from the diffuser for final installation of the filter in the field (by others).

The manufacturer shall provide published performance data for the diffuser, which shall be tested in accordance with ANSI/ASHRAE Standard 70 – 1991.

## HOW TO SPECIFY OR TO ORDER

(Show complete Model Number and Size, unless "Default" is desired).

### Stainless Steel Laminar Flow Diffuser with Filter – Model 92LFDF-SS

**92LFDF-SS - 10 - 48 x 24 - L - #3 - HE - —**

**MODEL**

- 304 Stainless Steel      92LFDF-SS

**INLET SIZE**

06, 07, 08, 10, 12 (152, 178, 203, 254, 305)

**CEILING MODULE SIZE**

**Imperial Modules (inches) (mm)**

- 48 x 12 (1219 x 305)
- 60 x 12 (1524 x 305)
- 24 x 24 (610 x 610)
- 36 x 24 (914 x 610)
- 48 x 24 (1219 x 610)
- 60 x 24 (1524 x 610)

**Metric Modules (mm)**

- 1200 x 300
- 1500 x 300
- 600 x 600
- 900 x 600
- 1200 x 600
- 1500 x 600

**OPTIONS**

- None (default)      —
- 316 Stainless Steel Construction      316

**FILTER**

- HEPA Filter (default)      HE  
(99.99% on 0.3 µm)
- ULPA Filter      UL  
(99.9995% on 0.12 µm)
- Filter By Others      FBO

**FINISH**

- #3 Satin Polished (default)      #3
- Appliance White      AW
- Special Custom Color      SP

**FRAME TYPE**

- Lay-in T-Bar      L
- Surface Mount      S

HOSPITAL / CLEANROOM DIFFUSERS

**Note:**

1. Consult dimensional data as to limitations of model, module and neck size combinations.

**SUGGESTED SPECIFICATION:**

Furnish and install **Nailor Model 92LFDF-SS Laminar Flow Diffusers with Filters** of the sizes and capacities as shown on the plans and air distribution schedules. The diffusers shall be constructed entirely from 304 stainless steel (316 optional), minimum 24 gauge. The perforated face of the diffuser shall have 13% free area with 3/32" (2.4) dia. holes on 1/4" (6) staggered centers. The face shall be attached with 1/4 turn fasteners to allow for complete removal and access to the interior for cleaning. All diffusers are to include safety cables to prevent accidental dropping of the removable face. A disc type balancing damper shall be provided with all units. Integral earthquake hanger tabs shall be included with all units. All exposed surfaces shall have a #3 satin polished finish (optional finishes are available).

The diffuser plenum shall incorporate an integral filter frame to accommodate a Gel Seal filter. Filters shall be securely held in place by at least four mounting brackets allowing filter removal from the face of the diffuser without disturbing installed ductwork or the diffuser mounting surface. Filters shall incorporate a removable test port, to measure filter pressure drop, perform leakage (scan) tests and to adjust the balancing damper without removing the filter. The filters efficiency shall be HEPA: 99.99% minimum removal efficiency on 0.30 micrometer particle size (ULPA: 99.9995% minimum removal efficiency on 0.12 micrometer particle size optional). Filters shall incorporate an anodized extruded aluminum frame and a 2" (51) deep separatorless filter pack. All filters shall be UL 900 Class I Listed and Factory Mutual Approved. All filters shall be individually scan tested per Section 6.2 of IEST-RP-CC034.1. Filters are to be packaged independently from the diffuser for final installation of the filter in the field (by others).

The manufacturer shall provide published performance data for the diffuser, which shall be tested in accordance with ANSI/ASHRAE Standard 70 – 1991.

## Performance Data

### Model 92LFDF-AL, 92LFDF-SS

With HEPA Filter • 99.99% Minimum Removal Efficiency on 0.30 Micrometer Particle Size

### Imperial Units

### 8" (203 mm) dia. Inlet

Module Size	Airflow, CFM	100	120	140	160	180	200	220	240	260	280	290
48" x 12" * or 1200 mm x 300 mm	Total Pressure, Pt	0.17	0.24	0.33	0.43	0.55	0.68	0.82	0.98	1.14	1.33	1.42
	Static Pressure, Ps	0.16	0.24	0.32	0.42	0.53	0.66	0.79	0.94	1.11	1.28	1.38
	NC	—	17	19	22	25	27	29	31	34	35	37
	Throw, T	.5-1-2	.5-1-3	1-1.5-4	1.5-2-4	1.5-2.5-5	2-3.5-5	2.5-4-6	3-4.5-7	3-4.5-7.5	4-5.5-8	4.5-6-9
60" x 12" or 1500 mm x 300 mm	Total Pressure, Pt	0.11	0.16	0.22	0.28	0.36	0.44	0.54	0.64	0.75	0.87	0.93
	Static Pressure, Ps	0.11	0.15	0.21	0.27	0.34	0.42	0.51	0.61	0.71	0.83	0.89
	NC	—	16	18	21	24	25	28	30	33	34	36
	Throw, T	.5-1-2	1-1-3	1-1.5-4	1-2-4	1-2.5-4.5	2-3.5-5	2-4-5.5	3-4-6.5	3-5-7	4-5-8	4-6-8.5

Module Size	Airflow, CFM	100	120	140	160	180	200	220	240	260	280	295
24" x 24" * or 600 mm x 600 mm	Total Pressure, Pt	0.17	0.24	0.32	0.42	0.54	0.66	0.80	0.95	1.12	1.30	1.44
	Static Pressure, Ps	0.16	0.23	0.31	0.41	0.52	0.64	0.77	0.92	1.08	1.25	1.39
	NC	—	17	19	22	25	27	29	31	34	35	37
	Throw, T	.5-1-2	.5-1-3	1-1.5-4	1.5-2-4	1.5-2.5-5	2-3.5-6	2.5-4-6	3-4.5-7	3-4.5-7.5	4-5.5-8	4.5-6-9
36" x 24" or 900 mm x 600 mm	Total Pressure, Pt	0.07	0.10	0.14	0.18	0.23	0.29	0.35	0.41	0.48	0.56	0.62
	Static Pressure, Ps	0.07	0.10	0.13	0.17	0.21	0.26	0.32	0.38	0.45	0.52	0.58
	NC	—	15	18	21	24	26	28	30	33	34	36
	Throw, T	0-1-1.5	0-1-2	0-1-3	1-2-3.5	1-2-4.5	2-3-5	2-3-5.5	2-3-5-6	2.5-4.5-7	3-5-8	3-5-8
48" x 24" or 1200 mm x 600 mm	Total Pressure, Pt	0.05	0.07	0.09	0.12	0.15	0.18	0.22	0.27	0.31	0.36	0.40
	Static Pressure, Ps	0.04	0.06	0.08	0.10	0.13	0.16	0.20	0.24	0.28	0.32	0.36
	NC	—	—	17	20	23	25	27	30	32	33	35
	Throw, T	0-5-1.5	.5-1-2	.5-1-2.5	1-1.5-3	1-2-4	1-2-5	1.5-2.5-5	2-3-6	2-4-6.5	2-4.5-7	3-5-7

### 10" (254 mm) dia. Inlet

Module Size	Airflow, CFM	160	180	200	220	240	260	280	300	320	340	360
36" x 24" or 900 mm x 600 mm	Total Pressure, Pt	0.14	0.18	0.22	0.27	0.32	0.37	0.43	0.50	0.56	0.64	0.71
	Static Pressure, Ps	0.14	0.17	0.21	0.26	0.30	0.36	0.41	0.48	0.54	0.61	0.69
	NC	15	18	20	21	23	26	28	30	32	34	36
	Throw, T	1-2-3.5	1-2-4.5	2-3-5	2-3-5.5	2-3.5-6	2.5-4-7	3-5-8	3-5-8	4-5.5-8.5	4-6-9	5-7-9.5
48" x 24" or 1200 mm x 600 mm	Total Pressure, Pt	0.08	0.10	0.13	0.15	0.18	0.21	0.25	0.28	0.32	0.37	0.41
	Static Pressure, Ps	0.08	0.10	0.12	0.14	0.17	0.20	0.23	0.27	0.30	0.34	0.38
	NC	—	15	18	19	22	25	27	29	31	33	35
	Throw, T	1-1-3	1-2-4	1-2-5	1.5-2.5-5	2-3-6	2-4-6.5	2-4.5-7	3-5-7	3-5-8	4-6-8.5	5-7-9
60" x 24" or 1500 mm x 600 mm	Total Pressure, Pt	0.06	0.07	0.09	0.11	0.13	0.15	0.17	0.20	0.22	0.25	0.28
	Static Pressure, Ps	0.05	0.06	0.08	0.10	0.11	0.13	0.15	0.18	0.20	0.23	0.26
	NC	—	—	17	19	22	24	27	29	31	33	35
	Throw, T	1-1-3	1-2-4	1-2-5	1.5-2.5-5	2-3-6	2-4-6.5	2-4.5-7	3-5-7	3-5-8	4-6-8.5	5-7-9

### 12" (305 mm) dia. Inlet

Module Size	Airflow, CFM	230	260	290	315	345	375	400	430	460	490	520
48" x 24" or 1200 mm x 600 mm	Total Pressure, Pt	0.16	0.20	0.25	0.29	0.35	0.42	0.48	0.55	0.63	0.71	0.80
	Static Pressure, Ps	0.15	0.19	0.24	0.28	0.34	0.40	0.46	0.53	0.61	0.69	0.78
	NC	15	18	20	22	23	25	26	28	30	32	33
	Throw, T	1-2-6	1.5-3-6.5	2-4-7	3-5-8	4-5.5-8	4.5-6-8.5	5-7-9.5	5.5-7.5-10	6-8-11	6.5-8.5-11.5	7-9-12
60" x 24" or 1500 mm x 600 mm	Total Pressure, Pt	0.10	0.13	0.16	0.19	0.23	0.27	0.31	0.36	0.41	0.47	0.53
	Static Pressure, Ps	0.10	0.12	0.16	0.18	0.22	0.26	0.30	0.34	0.39	0.44	0.50
	NC	15	18	20	22	23	25	26	28	30	32	33
	Throw, T	1-2-6	2-3-6	2-4-7	3-5-8	4-5.5-7.5	4.5-6-8.5	5-6.5-9	5.5-7.5-9.5	6-8-10.5	6-8.5-11	6.5-8.5-11.5

**CFM** - cubic feet per minute

**FPM** - feet per minute velocity

**Pt** - total pressure - inches w.g.

**Ps** - static pressure - inches w.g.

**T** - throw in feet

**NC** - Noise Criteria (values) based on 10 dB room absorption, re 10<sup>-12</sup> watts.

#### Performance Notes:

1. Throws are the average vertical distance in feet to terminal velocities of 100, 75 and 50 fpm. Based upon a cooling ΔT of 10°F. 9 ft. ceiling.

2. Performance data is for diffusers with clean filters. Filters may be operated up to a final resistance of 2" w.g. (500 Pa).

3\* Maximum airflow shown is based on 150 fpm (0.76 m/s) velocity per square foot of filter face area. Exceeding these airflows may result in reduced filter efficiencies. Refer to the engineering section for more details.

4. Data derived from tests conducted in accordance with ANSI/ASHRAE Standard 70 – 1991.

## Performance Data

Model 92LFDF-AL, 92LFDF-SS

With HEPA Filter • 99.99% Minimum Removal Efficiency on 0.30 Micrometer Particle Size

Metric Units

8" (203 mm) dia. Inlet

Module Size	Airflow, L/S	47	57	66	76	85	94	104	113	123	132	137
1219 mm x 305 mm* or 1200 mm x 300 mm	Total Pressure, Pt	42	60	82	107	137	169	204	244	283	331	353
	Static Pressure, Ps	40	60	80	104	132	164	196	234	276	318	343
	NC	—	17	19	22	25	27	29	31	34	35	37
	Throw, T	0.2-0.3-0.6	0.2-0.3-0.9	0.3-0.5-1.2	0.5-0.6-1.2	0.5-0.8-1.5	0.6-1.1-1.5	0.8-1.2-1.8	0.9-1.4-2.1	0.9-1.4-2.3	1.2-1.7-2.4	1.4-1.8-2.7
1524 mm x 305 mm or 1500 mm x 300 mm	Total Pressure, Pt	27	40	55	70	89	109	134	159	186	216	231
	Static Pressure, Ps	27	37	52	67	84	104	127	152	177	206	221
	NC	—	16	18	21	24	25	28	30	33	34	36
	Throw, T	0.2-0.3-0.6	0.3-0.3-0.9	0.3-0.5-1.2	0.3-0.6-1.2	0.3-0.8-1.4	0.6-1.1-1.5	0.6-1.2-1.7	0.9-1.2-2.0	0.9-1.5-2.1	1.2-1.5-2.4	1.2-1.8-2.6

Module Size	Airflow, L/S	47	57	66	76	85	94	104	113	123	132	139
610 mm x 610 mm* or 600 mm x 600 mm	Total Pressure, Pt	42	60	80	104	134	164	199	236	278	323	358
	Static Pressure, Ps	40	57	77	102	129	159	191	229	268	311	346
	NC	—	17	19	22	25	27	29	31	34	35	37
	Throw, T	0.2-0.3-0.6	0.2-0.3-0.9	0.3-0.5-1.2	0.5-0.6-1.2	0.5-0.8-1.5	0.6-1.1-1.8	0.8-1.2-1.8	0.9-1.4-2.1	0.9-1.4-2.3	1.2-1.7-2.4	1.4-1.8-2.7
914 mm x 610 mm or 900 mm x 600 mm	Total Pressure, Pt	17	25	35	45	57	72	87	102	119	139	154
	Static Pressure, Ps	17	25	32	40	52	64	80	94	112	129	144
	NC	—	15	18	21	24	26	28	30	33	34	36
	Throw, T	0-0.3-0.5	0-0.3-0.6	0-0.3-0.9	0.3-0.6-1.1	0.3-0.6-1.4	0.6-0.9-1.5	0.6-0.9-1.7	0.6-1.1-1.8	0.8-1.4-2.1	0.9-1.5-2.4	0.9-1.5-2.4
1219 mm x 610 mm or 1200 mm x 600 mm	Total Pressure, Pt	12	17	22	30	37	45	55	67	77	89	99
	Static Pressure, Ps	10	15	20	25	32	40	50	60	70	80	89
	NC	—	—	17	20	23	25	27	30	32	33	35
	Throw, T	0-0.2-0.5	0.2-0.3-0.6	0.2-0.3-0.8	0.3-0.5-0.9	0.3-0.6-1.2	0.3-0.6-1.5	0.5-0.8-1.5	0.6-0.9-1.8	0.6-1.2-2.0	0.6-1.4-2.1	0.9-1.5-2.1

10" (254 mm) dia. Inlet

Module Size	Airflow, L/S	76	85	94	104	113	123	132	142	151	160	170
914 mm x 610 mm or 900 mm x 600 mm	Total Pressure, Pt	35	45	55	67	80	92	107	124	139	159	177
	Static Pressure, Ps	35	42	52	65	75	89	102	119	134	152	172
	NC	15	18	20	21	23	26	28	30	32	34	36
	Throw, T	0.3-0.6-1.1	0.3-0.6-1.4	0.6-0.9-1.5	0.6-0.9-1.7	0.6-1.1-1.8	0.8-1.2-2.1	0.9-1.5-2.4	0.9-1.5-2.4	1.2-1.7-2.6	1.2-1.8-2.7	1.5-2.1-2.9
1219 mm x 610 mm or 1200 mm x 600 mm	Total Pressure, Pt	20	25	32	37	45	52	62	70	80	92	102
	Static Pressure, Ps	20	25	30	35	42	50	57	67	75	85	94
	NC	—	15	18	19	22	25	27	29	31	33	35
	Throw, T	0.3-0.3-0.9	0.3-0.6-1.2	0.3-0.6-1.5	0.5-0.8-1.5	0.6-0.9-1.8	0.6-1.2-2.0	0.6-1.4-2.1	0.9-1.5-2.1	0.9-1.5-2.4	1.2-1.8-2.6	1.5-2.1-2.7
1524 mm x 610 mm or 1500 mm x 600 mm	Total Pressure, Pt	15	17	22	27	32	37	42	50	55	62	70
	Static Pressure, Ps	12	15	20	25	27	32	37	45	50	57	65
	NC	—	—	17	19	22	24	27	29	31	33	35
	Throw, T	0.3-0.3-0.9	0.3-0.6-1.2	0.3-0.6-1.5	0.5-0.8-1.5	0.6-0.9-1.8	0.6-1.2-2.0	0.6-1.4-2.1	0.9-1.5-2.1	0.9-1.5-2.4	1.2-1.8-2.6	1.5-2.1-2.7

12" (305 mm) dia. Inlet

Module Size	Airflow, L/S	109	123	137	149	163	177	189	203	217	231	245
1219 mm x 610 mm or 1200 mm x 600 mm	Total Pressure, Pt	40	50	62	72	87	104	119	137	157	177	199
	Static Pressure, Ps	37	47	60	70	85	99	114	132	152	172	194
	NC	15	18	20	22	23	25	26	28	30	32	33
	Throw, T	0.3-0.6-1.8	0.5-0.9-2.0	0.6-1.2-2.1	0.9-1.5-2.4	1.2-1.7-2.4	1.4-1.8-2.6	1.5-2.1-2.9	1.7-2.3-3.0	1.8-2.4-3.4	2.0-2.6-3.5	2.1-2.7-3.7
1524 mm x 610 mm or 1500 mm x 600 mm	Total Pressure, Pt	25	32	40	47	57	67	77	89	102	117	132
	Static Pressure, Ps	25	30	40	45	55	65	75	85	97	109	124
	NC	15	18	20	22	23	25	26	28	30	32	33
	Throw, T	0.3-0.6-1.8	0.6-0.9-1.8	0.6-1.2-2.1	0.9-1.5-2.4	1.2-1.7-2.3	1.4-1.8-2.6	1.5-2.0-2.7	1.7-2.3-2.9	1.8-2.4-3.2	1.8-2.6-3.4	2.0-2.6-3.5

L/S - litres per second

M/S - meters per second velocity

Pt - total pressure - Pa

Ps - static pressure - Pa

T - throw in meters

NC - Noise Criteria (values) based on 10 dB room absorption, re 10<sup>-12</sup> watts.

### Performance Notes:

1. Throws are the average vertical distance in meters to terminal velocities of 0.51, 0.38 and 0.25 m/s. Based upon a cooling ΔT of 5.5°C. 2.7 m ceiling.
2. Performance data is for diffusers with clean filters. Filters may be operated up to a final resistance of 2" w.g. (500 Pa).

3\* Maximum airflow shown is based on 150 fpm (0.76 m/s) velocity per square foot of filter face area. Exceeding these airflows may result in reduced filter efficiencies. Refer to the engineering section for more details.

4. Data derived from tests conducted in accordance with ANSI/ASHRAE Standard 70 – 1991.

## Performance Data

### Model 92LFDF-AL, 92LFDF-SS

With ULPA Filter • 99.9995% Minimum Removal Efficiency on 0.12 Micrometer Particle Size

Imperial Units

8" (203 mm) dia. Inlet

Module Size	Airflow, CFM	100	120	140	160	180	200	220	240	260	280	290
48" x 12" * or 1200 mm x 300 mm	Total Pressure, Pt	0.20	0.29	0.39	0.51	0.65	0.80	0.96	1.15	1.35	1.56	1.68
	Static Pressure, Ps	0.19	0.28	0.38	0.50	0.63	0.78	0.94	1.12	1.31	1.52	1.63
	NC	—	17	19	22	25	27	29	31	34	35	37
	Throw, T	.5-1-2	.5-1-3	1-1.5-4	1.5-2-4	1.5-2.5-5	2-3.5-5	2.5-4-6	3-4.5-7	3-4.5-7.5	4-5.5-8	4.5-6-9
60" x 12" or 1500 mm x 300 mm	Total Pressure, Pt	0.13	0.18	0.25	0.33	0.42	0.51	0.62	0.74	0.87	1.01	1.08
	Static Pressure, Ps	0.12	0.18	0.24	0.31	0.40	0.49	0.60	0.71	0.83	0.96	1.03
	NC	—	16	18	21	24	25	28	30	33	34	36
	Throw, T	.5-1-2	1-1-3	1-1.5-4	1-2-4	1-2.5-4.5	2-3.5-5	2-4-5.5	3-4-6.5	3-5-7	4-5-8	4-6-8.5

Module Size	Airflow, CFM	100	120	140	160	180	200	220	240	260	280	295
24" x 24" * or 600 mm x 600 mm	Total Pressure, Pt	0.19	0.28	0.38	0.50	0.63	0.78	0.94	1.12	1.31	1.52	1.69
	Static Pressure, Ps	0.19	0.27	0.37	0.48	0.61	0.75	0.91	1.09	1.28	1.48	1.64
	NC	—	17	19	22	25	27	29	31	34	35	37
	Throw, T	.5-1-2	.5-1-3	1-1.5-4	1.5-2-4	1.5-2.5-5	2-3.5-6	2.5-4-6	3-4.5-7	3-4.5-7.5	4-5.5-8	4.5-6-9
36" x 24" or 900 mm x 600 mm	Total Pressure, Pt	0.08	0.12	0.16	0.21	0.26	0.32	0.39	0.47	0.55	0.64	0.71
	Static Pressure, Ps	0.08	0.11	0.15	0.19	0.25	0.30	0.37	0.44	0.51	0.59	0.66
	NC	—	15	18	21	24	26	28	30	33	34	36
	Throw, T	0-1-1.5	0-1-2	0-1-3	1-2-3.5	1-2-4.5	2-3-5	2-3-5.5	2-3-5-6	2.5-4.5-7	3-5-8	3-5-8
48" x 24" or 1200 mm x 600 mm	Total Pressure, Pt	0.05	0.07	0.10	0.13	0.17	0.20	0.25	0.29	0.34	0.40	0.44
	Static Pressure, Ps	0.05	0.07	0.09	0.12	0.15	0.18	0.22	0.26	0.31	0.36	0.40
	NC	—	—	17	20	23	25	27	30	32	33	35
	Throw, T	0-5-1.5	.5-1-2	.5-1-2.5	1-1.5-3	1-2-4	1-2-5	1.5-2.5-5	2-3-6	2-4-6.5	2-4.5-7	3-5-7

10" (254 mm) dia. Inlet

Module Size	Airflow, CFM	160	180	200	220	240	260	280	300	320	340	360
36" x 24" or 900 mm x 600 mm	Total Pressure, Pt	0.17	0.21	0.26	0.31	0.37	0.44	0.51	0.58	0.66	0.75	0.84
	Static Pressure, Ps	0.16	0.20	0.25	0.30	0.36	0.42	0.49	0.56	0.64	0.72	0.81
	NC	15	18	20	21	23	26	28	30	32	34	36
	Throw, T	1-2-3.5	1-2-4.5	2-3-5	2-3-5.5	2-3.5-6	2.5-4-7	3-5-8	3-5-8	4-5.5-8.5	4-6-9	5-7-9.5
48" x 24" or 1200 mm x 600 mm	Total Pressure, Pt	0.09	0.12	0.15	0.18	0.21	0.25	0.29	0.33	0.37	0.42	0.47
	Static Pressure, Ps	0.09	0.11	0.14	0.17	0.20	0.23	0.27	0.31	0.35	0.40	0.44
	NC	—	15	18	19	22	25	27	29	31	33	35
	Throw, T	1-1-3	1-2-4	1-2-5	1.5-2.5-5	2-3-6	2-4-6.5	2-4.5-7	3-5-7	3-5-8	4-6-8.5	5-7-9
60" x 24" or 1500 mm x 600 mm	Total Pressure, Pt	0.06	0.08	0.10	0.12	0.14	0.17	0.19	0.22	0.25	0.29	0.32
	Static Pressure, Ps	0.06	0.07	0.09	0.11	0.13	0.15	0.18	0.20	0.23	0.26	0.29
	NC	—	—	17	19	22	24	27	29	31	33	35
	Throw, T	1-1-3	1-2-4	1-2-5	1.5-2.5-5	2-3-6	2-4-6.5	2-4.5-7	3-5-7	3-5-8	4-6-8.5	5-7-9

12" (305 mm) dia. Inlet

Module Size	Airflow, CFM	230	260	290	315	345	375	400	430	460	490	520
48" x 24" or 1200 mm x 600 mm	Total Pressure, Pt	0.18	0.23	0.29	0.34	0.41	0.49	0.55	0.64	0.73	0.83	0.93
	Static Pressure, Ps	0.18	0.23	0.28	0.33	0.40	0.47	0.54	0.62	0.71	0.80	0.91
	NC	15	18	20	22	23	25	26	28	30	32	33
	Throw, T	1-2-6	1.5-3-6.5	2-4-7	3-5-8	4-5.5-8	4.5-6-8.5	5-7-9.5	5.5-7.5-10	6-8-11	6.5-8.5-11.5	7-9-12
60" x 24" or 1500 mm x 600 mm	Total Pressure, Pt	0.12	0.15	0.19	0.22	0.27	0.32	0.36	0.41	0.47	0.54	0.61
	Static Pressure, Ps	0.11	0.14	0.18	0.21	0.25	0.30	0.34	0.39	0.45	0.51	0.58
	NC	15	18	20	22	23	25	26	28	30	32	33
	Throw, T	1-2-6	2-3-6	2-4-7	3-5-8	4-5.5-7.5	4.5-6-8.5	5-6-9.5	5.5-7.5-9.5	6-8-10.5	6-8.5-11	6.5-8.5-11.5

CFM - cubic feet per minute

FPM - feet per minute velocity

Pt - total pressure - inches w.g.

Ps - static pressure - inches w.g.

T - throw in feet

NC - Noise Criteria (values) based on 10 dB room absorption, re 10<sup>-12</sup> watts.

### Performance Notes:

1. Throws are the average vertical distance in feet to terminal velocities of 100, 75 and 50 fpm. Based upon a cooling ΔT of 10°F. 9 ft. ceiling.

2. Performance data is for diffusers with clean filters. Filters may be operated up to a final resistance of 2" w.g. (500 Pa).

3\* Maximum airflow shown is based on 150 fpm (0.76 m/s) velocity per square foot of filter face area. Exceeding these airflows may result in reduced filter efficiencies. Refer to the engineering section for more details.

4. Data derived from tests conducted in accordance with ANSI/ASHRAE Standard 70 – 1991.

## Performance Data

Model 92LFDF-AL, 92LFDF-SS

With ULPA Filter • 99.9995% Minimum Removal Efficiency on 0.12 Micrometer Particle Size

Metric Units

8" (203 mm) dia. Inlet

Module Size	Airflow, L/S	47	57	66	76	85	94	104	113	123	132	137
1219 mm x 305 mm* or 1200 mm x 300 mm	Total Pressure, Pt	50	72	97	127	162	199	239	286	336	388	418
	Static Pressure, Ps	47	70	94	124	157	194	234	278	326	378	405
	NC	—	17	19	22	25	27	29	31	34	35	37
	Throw, T	0.2-0.3-0.6	0.2-0.3-0.9	0.3-0.5-1.2	0.5-0.6-1.2	0.5-0.8-1.5	0.6-1.1-1.5	0.8-1.2-1.8	0.9-1.4-2.1	0.9-1.4-2.3	1.2-1.7-2.4	1.4-1.8-2.7
1524 mm x 305 mm or 1500 mm x 300 mm	Total Pressure, Pt	32	45	62	82	104	127	154	184	216	251	268
	Static Pressure, Ps	30	45	60	77	99	122	149	177	206	239	256
	NC	—	16	18	21	24	25	28	30	33	34	36
	Throw, T	0.2-0.3-0.6	0.3-0.3-0.9	0.3-0.5-1.2	0.3-0.6-1.2	0.3-0.8-1.4	0.6-1.1-1.5	0.6-1.2-1.7	0.9-1.2-2.0	0.9-1.5-2.1	1.2-1.5-2.4	1.2-1.8-2.6

Module Size	Airflow, L/S	47	57	66	76	85	94	104	113	123	132	139
610 mm x 610 mm* or 600 mm x 600 mm	Total Pressure, Pt	47	70	94	124	157	194	234	278	326	378	420
	Static Pressure, Ps	47	67	92	119	152	186	226	271	318	368	408
	NC	—	17	19	22	25	27	29	31	34	35	37
	Throw, T	0.2-0.3-0.6	0.2-0.3-0.9	0.3-0.5-1.2	0.5-0.6-1.2	0.5-0.8-1.5	0.6-1.1-1.8	0.8-1.2-1.8	0.9-1.4-2.1	0.9-1.4-2.3	1.2-1.7-2.4	1.4-1.8-2.7
914 mm x 610 mm or 900 mm x 600 mm	Total Pressure, Pt	20	30	40	52	65	80	97	117	137	159	177
	Static Pressure, Ps	20	27	37	47	62	75	92	109	127	147	164
	NC	—	15	18	21	24	26	28	30	33	34	36
	Throw, T	0-0.3-0.5	0-0.3-0.6	0-0.3-0.9	0.3-0.6-1.1	0.3-0.6-1.4	0.6-0.9-1.5	0.6-0.9-1.7	0.6-1.1-1.8	0.8-1.4-2.1	0.9-1.5-2.4	0.9-1.5-2.4
1219 mm x 610 mm or 1200 mm x 600 mm	Total Pressure, Pt	12	17	25	32	42	50	62	72	85	99	109
	Static Pressure, Ps	12	17	22	30	37	45	55	65	77	89	99
	NC	—	—	17	20	23	25	27	30	32	33	35
	Throw, T	0-0.2-0.5	0.2-0.3-0.6	0.2-0.3-0.8	0.3-0.5-0.9	0.3-0.6-1.2	0.3-0.6-1.5	0.5-0.8-1.5	0.6-0.9-1.8	0.6-1.2-2.0	0.6-1.4-2.1	0.9-1.5-2.1

10" (254 mm) dia. Inlet

Module Size	Airflow, L/S	76	85	94	104	113	123	132	142	151	160	170
914 mm x 610 mm or 900 mm x 600 mm	Total Pressure, Pt	42	52	65	77	92	109	127	144	164	186	209
	Static Pressure, Ps	40	50	62	75	89	104	122	139	159	179	201
	NC	15	18	20	21	23	26	28	30	32	34	36
	Throw, T	0.3-0.6-1.1	0.3-0.6-1.4	0.6-0.9-1.5	0.6-0.9-1.7	0.6-1.1-1.8	0.8-1.2-2.1	0.9-1.5-2.4	0.9-1.5-2.4	1.2-1.7-2.6	1.2-1.8-2.7	1.5-2.1-2.9
1219 mm x 610 mm or 1200 mm x 600 mm	Total Pressure, Pt	22	30	37	45	52	62	72	82	92	104	117
	Static Pressure, Ps	22	27	35	42	50	57	67	77	87	99	109
	NC	—	15	18	19	22	25	27	29	31	33	35
	Throw, T	0.3-0.3-0.9	0.3-0.6-1.2	0.3-0.6-1.5	0.5-0.8-1.5	0.6-0.9-1.8	0.6-1.2-2.0	0.6-1.4-2.1	0.9-1.5-2.1	0.9-1.5-2.4	1.2-1.8-2.6	1.5-2.1-2.7
1524 mm x 610 mm or 1500 mm x 600 mm	Total Pressure, Pt	15	20	25	30	35	42	47	55	62	72	80
	Static Pressure, Ps	15	17	22	27	32	37	45	50	57	65	72
	NC	—	—	17	19	22	24	27	29	31	33	35
	Throw, T	0.3-0.3-0.9	0.3-0.6-1.2	0.3-0.6-1.5	0.5-0.8-1.5	0.6-0.9-1.8	0.6-1.2-2.0	0.6-1.4-2.1	0.9-1.5-2.1	0.9-1.5-2.4	1.2-1.8-2.6	1.5-2.1-2.7

12" (305 mm) dia. Inlet

Module Size	Airflow, L/S	109	123	137	149	163	177	189	203	217	231	245
1219 mm x 610 mm or 1200 mm x 600 mm	Total Pressure, Pt	45	57	72	85	102	122	137	159	181	206	231
	Static Pressure, Ps	45	57	70	82	99	117	134	154	177	199	226
	NC	15	18	20	22	23	25	26	28	30	32	33
	Throw, T	0.3-0.6-1.8	0.5-0.9-2.0	0.6-1.2-2.1	0.9-1.5-2.4	1.2-1.7-2.4	1.4-1.8-2.6	1.5-2.1-2.9	1.7-2.3-3.0	1.8-2.4-3.4	2.0-2.6-3.5	2.1-2.7-3.7
1524 mm x 610 mm or 1500 mm x 600 mm	Total Pressure, Pt	30	37	47	55	67	80	89	102	117	134	152
	Static Pressure, Ps	27	35	45	52	62	75	85	97	112	127	144
	NC	15	18	20	22	23	25	26	28	30	32	33
	Throw, T	0.3-0.6-1.8	0.6-0.9-1.8	0.6-1.2-2.1	0.9-1.5-2.4	1.2-1.7-2.3	1.4-1.8-2.6	1.5-2.0-2.7	1.7-2.3-2.9	1.8-2.4-3.2	1.8-2.6-3.4	2.0-2.6-3.5

L/S - litres per second

M/S - meters per second velocity

Pt - total pressure - Pa

Ps - static pressure - Pa

T - throw in meters

NC - Noise Criteria (values) based on 10 dB room absorption, re 10<sup>-12</sup> watts.

### Performance Notes:

1. Throws are the average vertical distance in meters to terminal velocities of 0.51, 0.38 and 0.25 m/s. Based upon a cooling ΔT of 5.5°C. 2.7 m ceiling.
2. Performance data is for diffusers with clean filters. Filters may be operated up to a final resistance of 2" w.g. (500 Pa).

3\* Maximum airflow shown is based on 150 fpm (0.76 m/s) velocity per square foot of filter face area. Exceeding these airflows may result in reduced filter efficiencies. Refer to the engineering section for more details.

4. Data derived from tests conducted in accordance with ANSI/ASHRAE Standard 70 – 1991.