

## ROUND CEILING DIFFUSERS

- ARCHITECTURAL PLAQUE FACE
- ADJUSTABLE HORIZONTAL PATTERN
- ALUMINUM FACE

**Model:**  
**R-UNI**

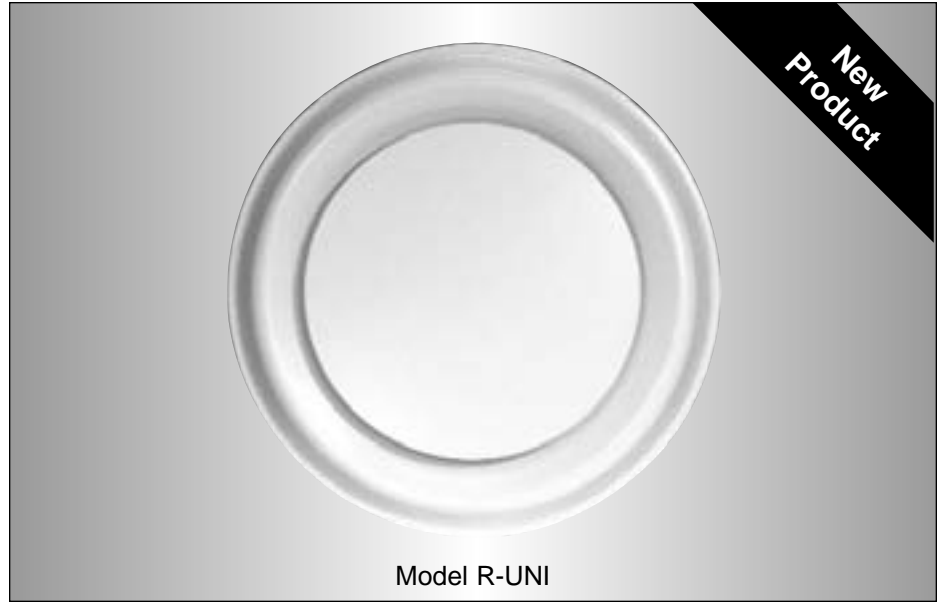

**D**

The **Nailor Model R-UNI Round Plaque Ceiling Air Diffuser** has been designed to provide both the appearance required for architectural excellence as well as high engineering performance. These diffusers are suitable for both architectural ceilings and exposed duct applications.

The diffusers deliver the air in a true 360° air pattern and provide excellent performance in variable air volume systems. The discharge setting is simply adjusted by sliding the inner face plaque assembly up or down. The diffuser provides higher induction and more air movement in the higher position while maximum capacity at minimum NC levels can be obtained in the lower position.

### FEATURES:

- Smooth heavy duty face plaque is 1/8" (0.125) thick aluminum for strength and lightness.
- A spring clip arrangement permits quick, easy installation and removal of the inner cone assembly.
- The core is retained by a spring loaded friction arrangement. There are no screws to reposition.
- An optional radial opposed blade damper with an operating arm to adjust the damper without removing the core is available.
- Available for duct sizes 6" – 16" (152 – 406) diameter.
- High neck collars for solid connection.

**Material:** Corrosion-resistant steel outer cone and bracketry with an aluminum face.

**Finish:** AW Appliance White baked enamel finish is standard. Other finishes are available.

**CEILING DIFFUSERS**

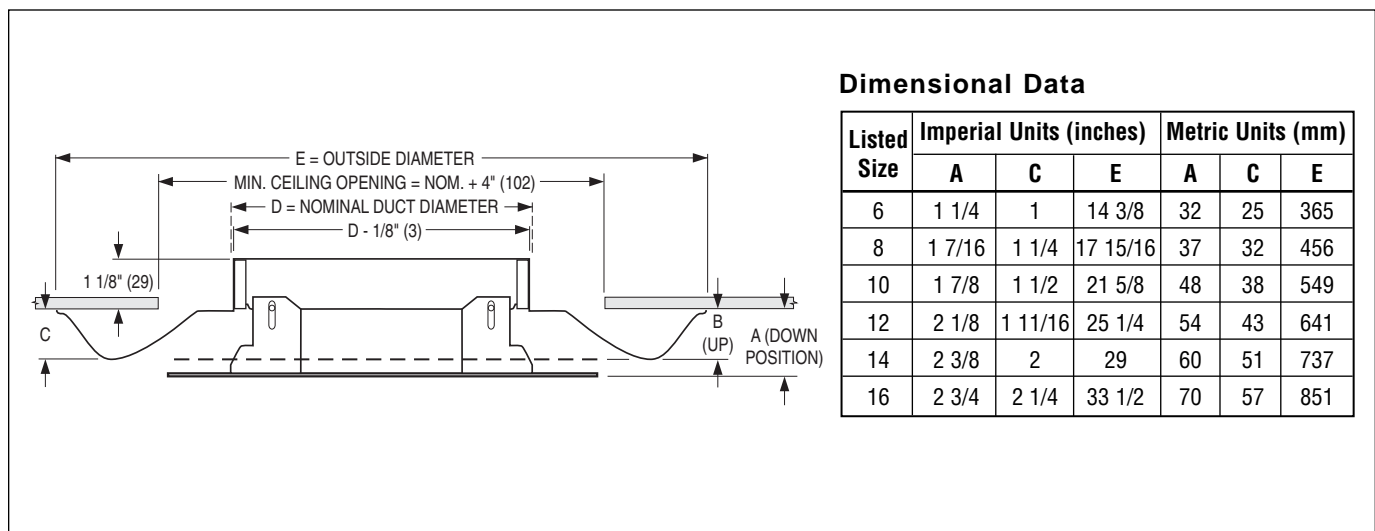

## HOW TO SPECIFY OR TO ORDER

(Show complete Model Number and Size, unless "Default" is desired).

### Round Plaque Ceiling Diffusers – Model Series R-UNI

**R-UNI - 12 - AW - -**

**MODEL**

Plaque Face Adjustable (Horizontal) R-UNI

**LISTED NECK SIZE**

Imperial (inches)	Metric (mm)
- 06	152
- 08	203
- 10	254
- 12	305
- 14	356
- 16	406

**ACCESSORIES**

- None (default) —
- Safety Chain SC
- Earthquake Tabs EQT
- Foam Gasket GK

**AIR BALANCING DEVICES**

- Radial Sliding Blade Damper 4250
- Radial Opposed Blade Damper 4275
- Radial OBD with Operating Arm 4275-OA
- Butterfly Damper 4675
- Equalizing Grid EGR
- Damper/Equalizing Grid DEGR

**FINISH**

- Appliance White (default) AW
- Aluminum AL
- Special Custom Color SP

**D**  
**CEILING DIFFUSERS**

**Note:**

1. If more than one accessory is required, list in order.

**SUGGESTED SPECIFICATION:**

Furnish and install **Nailor Model R-UNI Round Architectural Plaque Face Ceiling Diffusers** of the sizes and capacities as shown on the plans and air distribution schedules. The diffuser shall have a round outer cone that is spun from corrosion-resistant steel. The inner core shall have a round plaque face that is heavy gauge aluminum, and shall be smooth and flat in appearance. A removable inner core assembly shall slide up or down to attain infinite horizontal discharge patterns. The finish shall be AW Appliance White baked enamel (optional finishes are available).

The manufacturer shall provide published performance data for the diffuser, which shall be tested in accordance with ANSI/ASHRAE Standard 70 – 1991.

## Performance Data

### Model R-UNI

Nominal Neck Size	Neck Velocity, fpm	400	500	600	700	800	900	1000	1200	1400	1600
	Velocity Pressure	.010	.016	.022	.031	.040	.050	.062	.090	.122	.160
<b>6" Dia.</b>	Total Pressure	.034	.053	.076	.103	.134	.169	.209	.300	.407	.531
	Airflow, cfm	<b>79</b>	<b>98</b>	<b>118</b>	<b>137</b>	<b>157</b>	<b>177</b>	<b>196</b>	<b>236</b>	<b>275</b>	<b>314</b>
	Throw	1-2-3	2-2-5	2-3-7	3-4-9	3-5-10	4-6-12	4-7-13	6-9-14	7-11-15	8-13-17
	NC	—	—	—	—	16	21	24	30	36	41
<b>8" Dia.</b>	Total Pressure	.033	.052	.075	.104	.136	.174	.216	.315	.432	.569
	Airflow, cfm	<b>140</b>	<b>175</b>	<b>209</b>	<b>244</b>	<b>279</b>	<b>314</b>	<b>349</b>	<b>419</b>	<b>489</b>	<b>559</b>
	Throw	1-2-3	2-2-5	2-3-8	3-4-10	3-5-12	4-7-13	4-8-15	6-11-17	7-14-19	9-18-21
	NC	—	—	—	—	17	21	25	33	40	46
<b>10" Dia.</b>	Total Pressure	.048	.074	.106	.143	.185	.232	.285	.405	.546	.707
	Airflow, cfm	<b>218</b>	<b>273</b>	<b>327</b>	<b>382</b>	<b>436</b>	<b>491</b>	<b>545</b>	<b>654</b>	<b>764</b>	<b>873</b>
	Throw	1-2-5	2-2-6	2-3-8	3-4-10	3-6-13	4-8-13	5-9-14	6-15-20	8-16-21	10-19-22
	NC	—	—	—	—	15	20	23	28	34	37
<b>12" Dia.</b>	Total Pressure	.047	.073	.104	.141	.184	.233	.287	.411	.558	.727
	Airflow, cfm	<b>314</b>	<b>393</b>	<b>471</b>	<b>550</b>	<b>628</b>	<b>707</b>	<b>785</b>	<b>942</b>	<b>1100</b>	<b>1257</b>
	Throw	2-4-9	2-6-11	3-7-13	4-8-14	5-9-15	6-10-17	7-11-18	9-13-19	12-15-21	14-18-22
	NC	—	—	—	—	17	20	22	28	33	37
<b>14" Dia.</b>	Total Pressure	.051	.080	.116	.159	.209	.265	.328	.476	.651	.854
	Airflow, cfm	<b>428</b>	<b>535</b>	<b>641</b>	<b>748</b>	<b>855</b>	<b>962</b>	<b>1069</b>	<b>1283</b>	<b>1497</b>	<b>1710</b>
	Throw	4-7-14	5-9-16	6-10-17	7-12-18	9-13-20	10-14-21	11-15-21	14-18-23	17-20-24	20-22-25
	NC	—	—	16	20	24	28	36	43	49	54
<b>16" Dia.</b>	Total Pressure	.058	.090	.130	.177	.232	.293	.362	.522	.711	.929
	Airflow, cfm	<b>559</b>	<b>698</b>	<b>838</b>	<b>977</b>	<b>1117</b>	<b>1257</b>	<b>1396</b>	<b>1676</b>	<b>1955</b>	<b>2234</b>
	Throw	6-8-12	7-10-16	9-12-18	10-14-21	12-15-23	13-17-25	14-19-26	17-22-29	20-25-31	22-28-33
	NC	—	—	—	—	15	19	25	30	35	41

#### Performance Notes:

1. All pressures are in inches w.g.. To obtain static pressure, subtract the velocity pressure from the total pressure.
2. Throws are given at 150, 100 and 50 fpm terminal velocities, under isothermal conditions.

3. NC (Noise Criteria) values are based on 10 dB room absorption, re 10<sup>-12</sup> watts. Dash (–) in spaces indicates an NC level of less than 15.
4. Data derived from tests conducted in accordance with ANSI/ASHRAE Standard 70 – 1991.

#### Balancing:

It is recommended that a commercially available 'Flow Hood' is used for field balancing. The airflow meter directly reads average flow rate with great accuracy at all volumes. It is a much faster and more accurate alternative to time consuming multiple velocity readings, eliminating the use of Ak factors and the calculations required to convert the average velocity into airflow.