

SQUARE MODULAR CORE DIFFUSERS

- 1, 2, 3 OR 4-WAY ADJUSTABLE DISCHARGE PATTERN

Steel Model:

7500

- Suffix '-O' adds a steel opposed blade damper

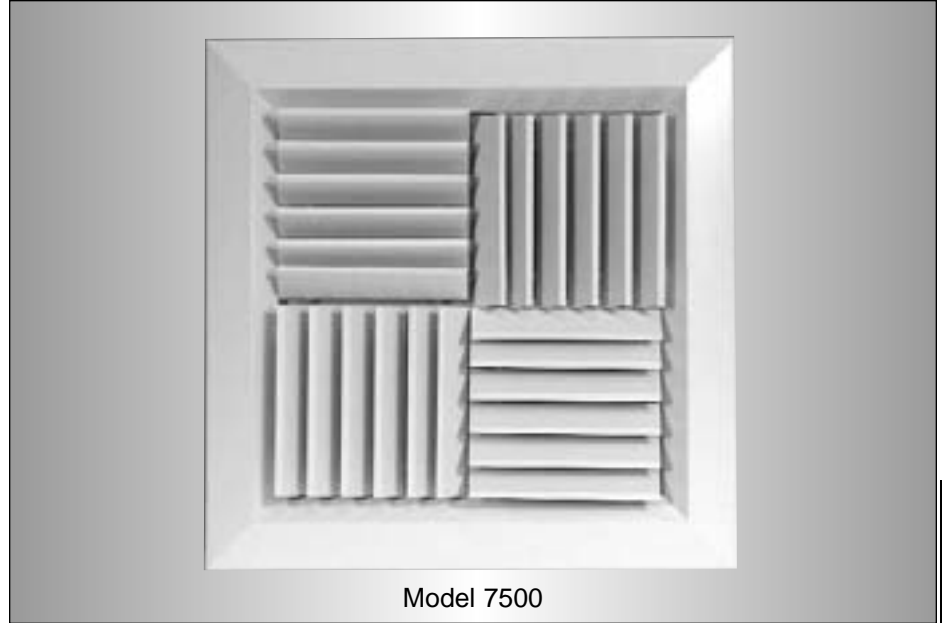

The **Nailor 7500 Series Diffusers** have been specially designed to provide a versatile 'modular core' product which is available in a comprehensive range of sizes and air capacities, providing optimum simplicity and flexibility for field adjustment of the discharge air pattern. They maintain a horizontal ceiling pattern from maximum to minimum flow and make an excellent choice for use in variable air volume systems.

The **7500 Series** features four individual spring-loaded 'modular' pattern controllers mounted in the neck. They can be adjusted before or after installation, to provide a 1, 2, 3 or 4-way discharge pattern by simply rotating one or more of the pattern controllers which takes only a few seconds.

FEATURES:

- Square neck is standard.
- Round transition adaptors are available (SR option).
- Each diffuser features four individually adjustable 'spring-loaded' modular cores.
- Simple adjustment for a 1, 2, 3 or 4-way horizontal discharge pattern without the use of tools.
- Inlet collar has 1 1/2" (38) depth for easy duct connection.
- A wide variety of frame styles to suit most ceiling applications.
- Optional extended panels to suit modular T-Bar ceiling systems.
- Optional opposed blade damper with screwdriver slot operator is adjustable from the diffuser face by removing a modular core.

Material: Corrosion-resistant steel blades and frame.

Finish: AW Appliance White baked enamel finish is standard. Other finishes are available.

Modular Core Adjustments

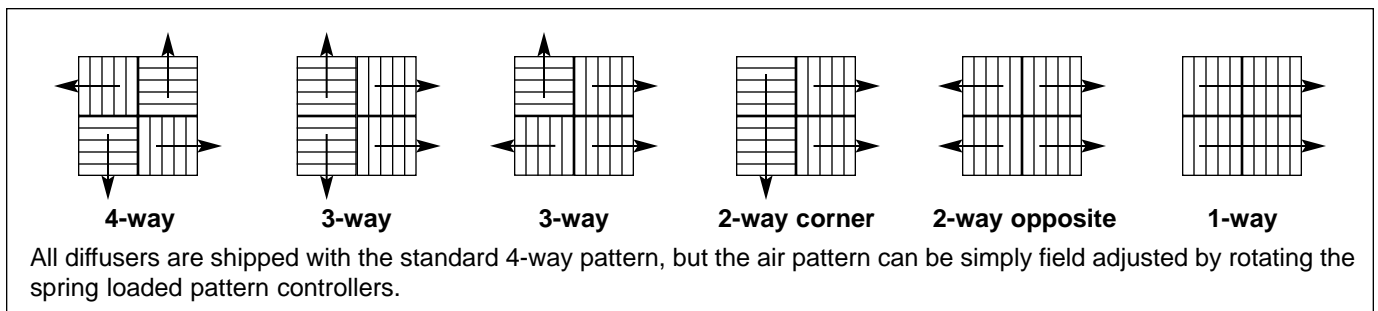

Dimensional Data and Frame Types

Model Series 7500

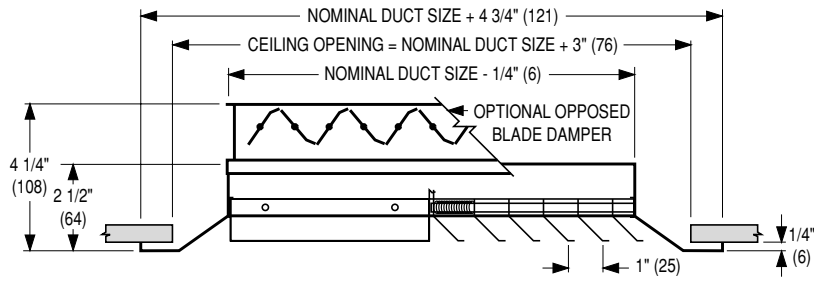

Type S - Surface Mount Frame

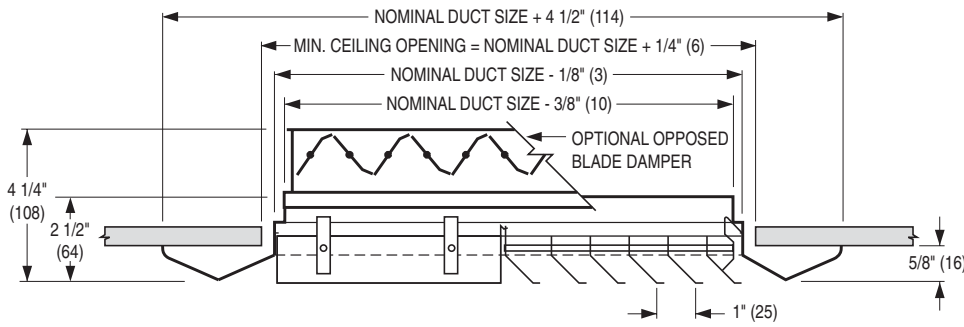
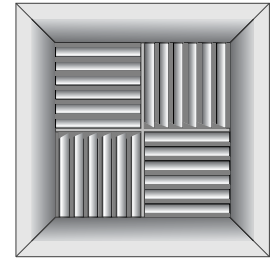

Type BS - Beveled Surface Mount Frame (Low Profile)

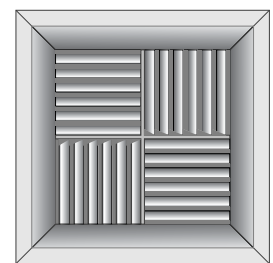

D
CEILING DIFFUSERS

Available Duct Sizes

Frame Types S and BS		
6 x 6 (152 x 152)	12 x 12 (305 x 305)	18 x 18 (457 x 457)
8 x 8 (203 x 203)	14 x 14 (356 x 356)	20 x 20 (508 x 508)
9 x 9 (229 x 229)	15 x 15 (381 x 381)	22 x 22 (559 x 559)
10 x 10 (254 x 254)	16 x 16 (406 x 406)	24 x 24 (610 x 610)

Dimensional Data and Frame Types

Model Series 7500

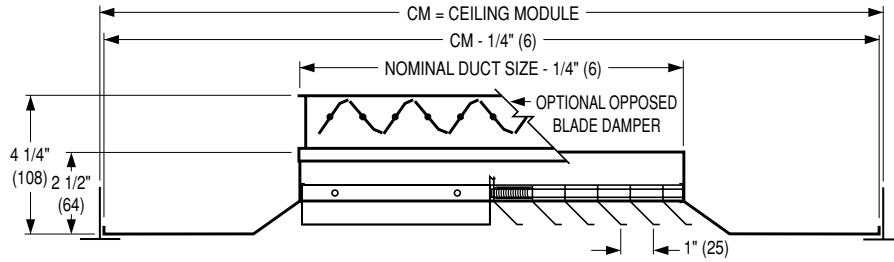

**Type L - Lay-In
T-Bar Frame**

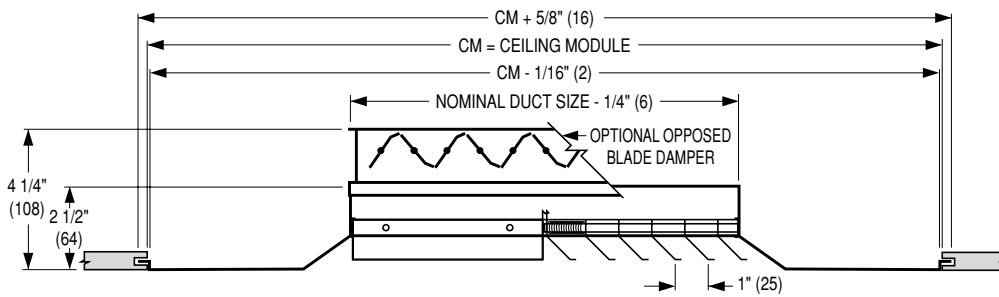
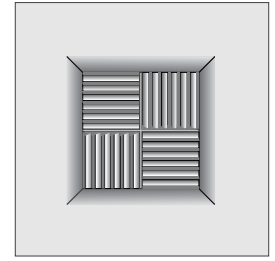

Type SP - Spline Frame

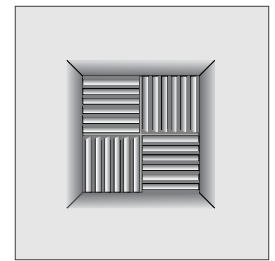

SPLINE TYPE DIFFUSER FOR ONE-DIRECTIONAL EXPOSED T-BAR LAY-IN GRID OR FOR CONCEALED T-BAR GRID.
(SPLINES ON TWO OPPOSITE SIDES. STEEL LIFT BRACKETS ON THE OTHER TWO SIDES).

Type M Metal Pan (Snap-in)

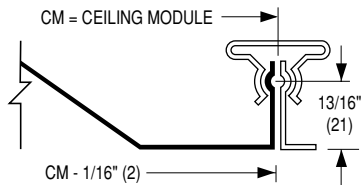

Type F Fineline®

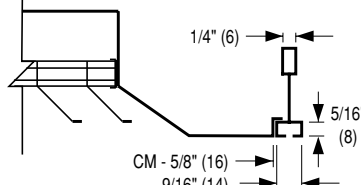

Type TL Tegular

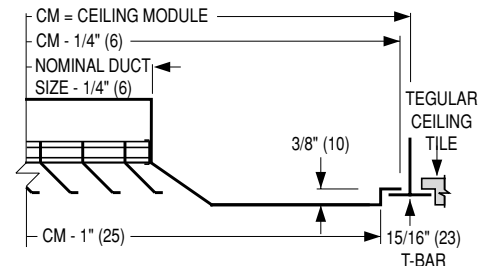

Extended Panel Diffusers

Frame Types L, SP, TL, F and M

If the ceiling module is more than 3" (76) larger than the neck size of the diffuser in either or both dimensions, a module-sized extended panel will be added.

See the table (below) for the maximum duct size for each module size.

Ceiling Module Size CM – Frame Types L, SP, M, TL and F		
Imperial Modules (inches)	Metric Modules (mm)	Available Duct Sizes
12 x 12, 24 x 12	300 x 300, 600 x 300	6 x 6 (152 x 152) 8 x 8 (203 x 203) 9 x 9 (229 x 229)
20 x 20	500 x 500	6 x 6 (152 x 152) 10 x 10 (254 x 254) 15 x 15 (381 x 381)
		8 x 8 (203 x 203) 12 x 12 (305 x 305)
		9 x 9 (229 x 229) 14 x 14 (356 x 356)
24 x 24	600 x 600	6 x 6 (152 x 152) 10 x 10 (254 x 254) 15 x 15 (381 x 381)
		8 x 8 (203 x 203) 12 x 12 (305 x 305) 16 x 16 (406 x 406)
		9 x 9 (229 x 229) 14 x 14 (356 x 356) 18 x 18 (457 x 457)

HOW TO SPECIFY OR TO ORDER

(Show complete Model Number and Size, unless "Default" is desired).

Modular Core Ceiling Diffusers – Model Series 7500

7500 - O - 9 x 9 - 24 x 24 - L - AW - -

MODEL

- Steel 7500

DAMPER

- No Damper (default) —
 - Opposed Blade (steel) O

NECK SIZE (inches)

6 x 6, 8 x 8, 9 x 9, 10 x 10
 12 x 12, 14 x 14, 15 x 15,
 16 x 16, 18 x 18, 20 x 20,
 22 x 22, 24 x 24

CEILING MODULE SIZE

(Frame Types L, SP, M, TL and F)

Imperial (in.)	Metric (mm)
12 x 12	300 x 300
20 x 20	500 x 500
24 x 12	600 x 300
24 x 24	600 x 600

ACCESSORIES

- None (default) —
 - External Foil Back Insulation EX
 - Earthquake Tabs EQT
 - Square to Round Transition Collar (04 thru 16 specify) SR

AIR BALANCING DEVICES

Square Neck

- Equalizing Grid EGL
 - Damper/Equalizing Grid DEGL

Round Neck

- Radial Sliding Blade Damper 4250
 - Radial Opposed Blade Damper 4275
 - Butterfly Damper 4675
 - Equalizing Grid EGR
 - Damper/Equalizing Grid DEGR

FINISH

- Appliance White (default) AW
 - Aluminum AL
 - Special Custom Color SP

FRAME TYPE

- Surface Mount S
 - Bevelled Surface Mount BS
 - Lay-in T-Bar L
 - Spline SP
 - Metal Pan Snap-in M
 - Finline® F
 - Tegular (Drop Face) TL

D
CEILING DIFFUSERS

Notes:

1. Consult individual models as to limitations of panel and neck size combinations.
2. If more than one accessory is required, list in order.

SUGGESTED SPECIFICATION:

Furnish and install **Nailor Model Series 7500 Modular Core Ceiling Diffusers** of the sizes and capacities as shown on the plans and air distribution schedules. The diffuser shall have a heavy gauge, corrosion-resistant steel frame and core. The modular deflectors shall consist of four square, individually adjustable pattern deflectors, factory installed in a 4-way pattern, that are easily field rotated to provide throws in a 1, 2, or 3-way pattern. The diffuser shall have a square duct connection collar that is an integral part of the frame assembly and not be less than 1 1/2" (38) high. The finish shall be AW Appliance White baked enamel (optional finishes are available).

(Optional) An opposed blade damper, constructed of heavy gauge corrosion-resistant steel and operable from the face of the diffuser, shall be provided with all units.

The manufacturer shall provide published performance data for the diffuser, which shall be tested in accordance with ANSI/ASHRAE Standard 70 – 1991.

Performance Data

Models 7500 • Square Neck

Nominal Neck Size Inches	Neck Velocity, FPM	200	300	400	500	600	700	800	900	1000	
	Velocity Pressure	.003	.006	.010	.016	.022	.031	.040	.051	.062	
	TP	.015	.032	.058	.090	.130	.177	.231	.293	.362	
6 x 6	Airflow, CFM	50	75	100	125	150	175	200	225	250	
	NC	—	—	11	17	22	26	29	32	35	
	T	4-Way	1-1-1	1-1-2	1-2-3	1-2-3	1-2-4	2-3-4	2-3-5	2-3-5	2-3-5
		3-Way	1-1-3	1-2-4	2-3-5	2-4-6	3-4-7	3-5-7	4-5-8	4-6-8	5-6-9
		2-Way	1-1-3	1-2-4	2-3-5	2-4-6	3-4-7	3-5-7	4-5-8	4-6-8	5-6-9
1-Way		1-2-4	2-3-7	3-4-8	3-5-9	4-7-9	5-7-10	6-8-11	7-8-12	7-9-12	
8 x 8	Airflow, CFM	88	133	177	222	266	310	355	399	444	
	NC	—	—	14	20	25	29	32	35	38	
	T	4-Way	1-2-4	2-3-6	2-4-8	3-5-9	4-6-10	4-7-11	5-8-11	6-8-12	6-9-13
		3-Way	2-3-7	3-5-11	5-7-13	6-9-14	7-11-15	8-12-17	10-13-18	11-14-19	12-14-20
		2-Way	2-3-7	3-5-11	5-7-13	6-9-14	7-11-15	8-12-17	10-13-18	11-14-19	12-14-20
1-Way		3-5-11	5-8-15	7-11-18	9-13-20	11-15-22	12-16-24	14-18-26	15-19-27	16-20-29	
10 x 10	Airflow, CFM	138	208	277	347	416	485	555	624	694	
	NC	—	13	20	22	27	31	34	37	40	
	T	4-Way	2-3-7	3-5-9	4-7-10	6-8-11	7-9-12	8-9-14	8-10-14	9-11-14	9-11-17
		3-Way	4-6-12	6-10-14	9-12-16	11-13-18	12-14-20	13-15-22	14-16-23	14-19-25	14-20-26
		2-Way	4-6-12	6-10-14	9-12-16	11-13-18	12-14-20	13-15-22	14-16-23	14-17-25	14-18-26
1-Way		6-9-16	9-14-20	13-16-23	14-18-26	16-20-28	17-21-31	18-23-33	20-24-35	21-26-37	
12 x 12	Airflow, CFM	200	300	400	500	600	700	800	900	1000	
	NC	—	16	23	25	30	34	37	40	43	
	T	4-Way	2-4-8	4-6-11	5-8-12	7-10-14	8-11-14	9-11-15	10-12-17	11-13-18	11-14-19
		3-Way	5-8-14	8-12-17	10-14-20	13-15-22	14-17-24	15-18-26	16-20-28	17-21-30	18-22-32
		2-Way	5-8-14	8-12-17	10-14-20	13-15-22	14-17-24	15-18-26	16-20-28	17-21-30	18-22-32
1-Way		7-11-19	11-16-24	14-19-28	17-22-31	19-24-34	21-26-37	22-28-40	24-30-42	25-31-45	
14 x 14	Airflow, CFM	272	408	544	680	816	952	1088	1224	1361	
	NC	—	18	25	27	32	36	39	42	45	
	T	4-Way	3-5-10	5-7-12	6-10-14	8-11-15	10-12-19	11-13-18	12-14-19	12-14-21	13-15-22
		3-Way	6-9-16	9-14-20	12-16-23	14-18-26	16-20-29	17-21-31	19-23-33	20-25-35	21-26-37
		2-Way	6-9-16	9-14-20	12-16-23	14-18-26	16-20-29	17-21-31	19-23-33	20-25-35	21-26-37
1-Way		9-13-23	13-19-28	17-23-33	21-25-37	23-28-40	25-30-44	26-33-47	28-35-49	30-37-51	
16 x 16	Airflow, CFM	355	533	711	889	1066	1244	1422	1600	1778	
	NC	—	20	27	29	34	38	41	44	47	
	T	4-Way	3-5-11	5-8-14	7-11-15	9-13-17	11-14-19	12-14-21	13-15-23	14-17-24	14-17-25
		3-Way	7-10-18	10-15-23	14-18-27	17-21-30	18-23-33	20-25-36	21-27-38	23-28-41	24-30-43
		2-Way	7-10-18	10-15-23	14-18-27	17-21-30	18-23-33	20-25-38	21-27-38	23-28-41	24-31-43
1-Way		10-14-26	14-22-32	20-26-38	24-29-42	26-32-46	28-35-49	30-38-53	32-40-56	34-42-59	

- CFM** - cubic feet per minute
- FPM** - feet per minute velocity
- TP** - total pressure - inches w.g.
- T** - throw in feet
- NC** - Noise Criteria (values) based on 10 dB room absorption, re 10⁻¹² watts.

Performance Notes:

1. Throws are given at 150, 100 and 50 fpm terminal velocities under isothermal conditions.
2. Data derived from tests conducted in accordance with ANSI/ASHRAE Standard 70 – 1991.

Neck Size Square in Inches	Ak Factor
6 x 6	0.1134
8 x 8	0.1932
9 x 9	0.2551
10 x 10	0.3024
12 x 12	0.4526
14 x 14	0.5883
15 x 15	0.6804
16 x 16	0.7728

Performance Data

Models 7500 • Square Neck

Nominal Neck Size Inches	Neck Velocity FPM	200	300	400	500	600	700	800	900	1000	
	Velocity Pressure	.003	.006	.010	.016	.022	.031	.040	.051	.062	
	TP	.015	.032	.058	.090	.130	.177	.231	.293	.362	
18 x 18	Airflow, CFM	450	675	900	1125	1350	1575	1800	2025	2250	
	NC	—	22	28	30	35	39	42	45	48	
	T	4-Way	4-6-13	6-10-15	8-13-18	11-14-20	13-15-22	14-16-24	14-18-26	15-19-27	16-20-29
		3-Way	8-12-21	12-17-26	15-21-30	19-23-34	21-26-37	23-28-40	24-30-43	26-32-46	27-34-48
		2-Way	8-12-21	12-17-26	15-21-30	19-23-34	21-26-37	23-28-40	24-30-43	26-32-46	27-34-48
1-Way		11-16-30	16-25-37	22-30-42	27-33-48	30-37-51	32-40-56	34-42-60	36-45-63	39-48-67	
20 x 20	Airflow, CFM	555	835	1110	1390	1665	1945	2220	2500	2775	
	NC	11	24	30	32	37	41	44	47	50	
	T	4-Way	4-7-14	7-11-17	9-14-20	12-15-22	14-17-24	15-18-27	16-20-29	17-21-30	18-22-32
		3-Way	9-13-23	13-19-29	17-23-34	21-26-38	23-29-41	25-31-45	27-34-48	29-36-50	30-38-53
		2-Way	9-13-23	13-19-29	17-23-34	21-26-38	23-29-41	25-31-45	27-34-48	29-36-51	30-38-53
1-Way		13-18-33	18-28-43	25-33-47	30-37-52	33-41-57	36-44-62	38-47-67	41-49-71	43-52-75	
22 x 22	Airflow, CFM	675	1000	1345	1680	2015	2350	2690	3025	3360	
	NC	13	26	32	34	39	43	46	49	52	
	T	4-Way	5-8-15	8-12-19	10-15-22	13-17-25	15-19-27	16-20-29	18-22-31	19-23-34	20-25-35
		3-Way	10-14-26	14-21-32	19-26-37	23-29-42	26-32-46	28-35-48	30-37-52	32-39-55	34-41-58
		2-Way	10-14-26	14-21-32	19-26-37	23-29-42	26-32-46	28-35-48	30-37-52	32-39-55	34-41-58
1-Way		14-20-36	20-31-45	28-36-51	33-41-58	36-45-63	39-48-68	41-51-73	45-54-78	47-58-81	
24 x 24	Airflow, CFM	800	1200	1600	2000	2400	2800	3200	3600	4000	
	NC	15	28	34	36	41	45	48	51	54	
	T	4-Way	5-8-16	8-13-21	11-16-24	14-19-27	16-21-30	18-22-32	19-24-35	21-26-37	22-27-39
		3-Way	10-15-28	15-23-35	20-28-41	26-32-45	28-35-49	31-38-53	33-41-57	35-43-61	37-45-64
		2-Way	10-15-28	15-23-35	20-28-41	26-32-45	28-35-49	31-38-53	33-41-57	35-43-61	37-45-64
1-Way		14-22-40	22-34-48	30-40-56	36-45-63	40-48-69	43-52-75	45-56-79	48-60-84	51-63-89	

D
CEILING DIFFUSERS

CFM - cubic feet per minute
 FPM - feet per minute velocity
 TP - total pressure - inches w.g.
 T - throw in feet
 NC - Noise Criteria (values) based on 10 dB room absorption, re 10⁻¹² watts.

Performance Notes:
 1. Throws are given at 150, 100 and 50 fpm terminal velocities under isothermal conditions.
 2. Data derived from tests conducted in accordance with ANSI/ASHRAE Standard 70 – 1991.

Neck Size Square in Inches	Ak Factor
18 x 18	0.9541
20 x 20	1.2096
22 x 22	1.4636
24 x 24	1.7304