

SQUARE AND RECTANGULAR PATTERN CEILING DIFFUSERS

- LOUVERED FACE
- HIGH CAPACITY
- SQUARE, RECTANGULAR OR ROUND NECKS

Steel Models:

6500 Fixed Pattern

6550 Adjustable Pattern

Aluminum Models:

6200 Fixed Pattern

6250 Adjustable Pattern

- Suffix '-O' adds a steel opposed blade damper
- Suffix '-OA' adds an aluminum opposed blade damper (available on aluminum models only)

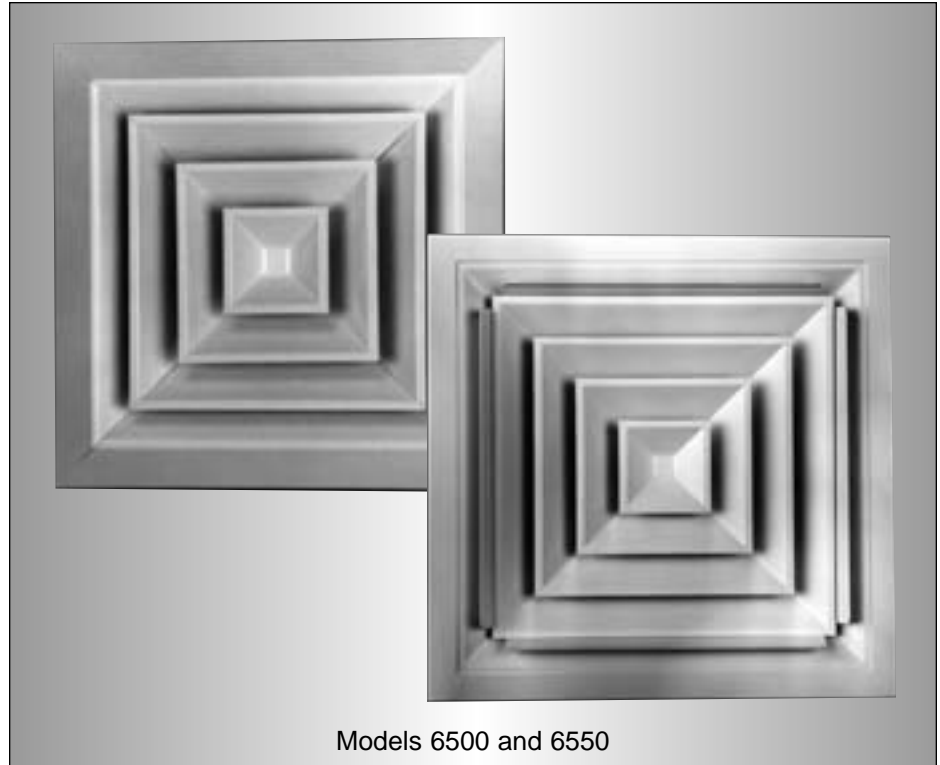

Models 6500 and 6550

D

CEILING DIFFUSERS

The **Nailor Model Series 6500 and 6200 Pattern Ceiling Diffusers** have been specially designed to provide a high capacity louvered face directional diffuser that can supply large volumes of air at relatively low sound levels and pressure drops. An engineered blade design with a 1/4" (6) horizontal lip on all angular discharge louvers creates a stable horizontal air pattern that is tight to the ceiling. Ideal for applications in VAV systems, these diffusers create a strong ceiling coanda effect at typical maximum and minimum airflow rates and ensure draft free air distribution.

Available with a wide variety of core styles and neck sizes, a combination can be selected to suit a specified air pattern and deliver the desired volume of air to suit any particular requirement. Many frame types are also available to suit almost any mounting condition including surface mount (flat, beveled or deep drop face) and T-Bar panel types (Standard 1" (25), Fineline®, Spline, Tegular or Metal Snap-in). These models therefore offer a great degree of design flexibility.

The **Nailor Model Series 6550 and 6250 Adjustable Pattern Ceiling Diffusers** offer the same features as the 6500 and 6200 Series, however, they feature four hinged, individually adjustable deflecting vanes. These vanes allow air pattern adjustment from horizontal to vertical and further enhance the flexibility of the diffuser. Ideal for applications with higher ceiling heights or for heating applications to minimize stratification.

FEATURES:

- Spring loaded core. Removable without the use of tools.
- High neck collars for solid connection.
- Secure core attachment.
- A wide variety of frame styles to suit most ceiling applications.
- Optional extended panels to suit modular ceiling systems.
- Engineered air diffusion patterns for 1, 2, 3 or 4-way blow in a wide selection of square and rectangular neck sizes (see page D16).
- Clean lines with no unsightly visible screws.
- Square-to-round transition adaptors are available (SR option).

- Optional opposed blade damper with screwdriver slot operator.

Material: **6500 Series** – Corrosion-resistant steel. **6200 Series** – Heavy-gauge aluminum extrusions.

Finish: AW Appliance White baked enamel finish is standard. Other finishes are available.

AVAILABLE SIZES:

Unit Size is determined by duct dimensions. Diffuser necks are undersized to suit ductwork.

Duct Sizes are available in 3" (76) increments.

Minimum size:

6" x 6" (152 x 152) square neck. 9" x 6" (229 x 152) rectangular neck (most core styles).

Maximum size:

Types S, B and D: 36" x 36" (914 x 914).

Types L, SP, TL, M and F: see page D14.

Dimensional Data and Frame Types

Model Series 6500 and 6200

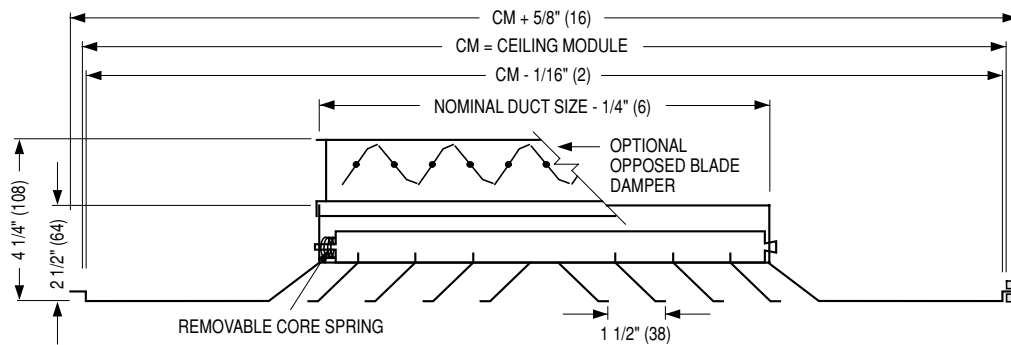
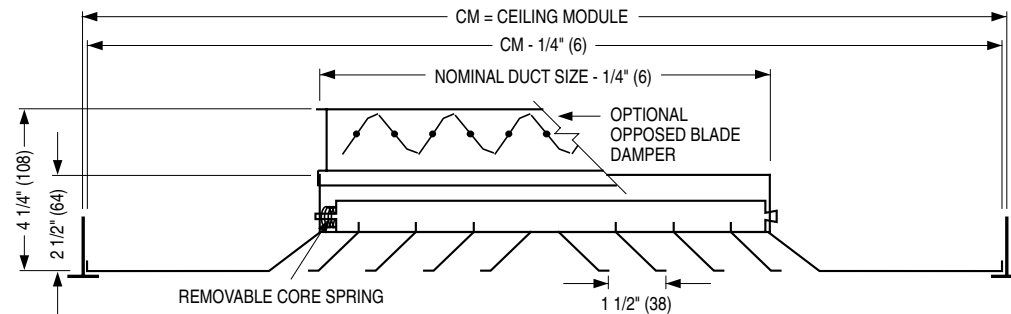
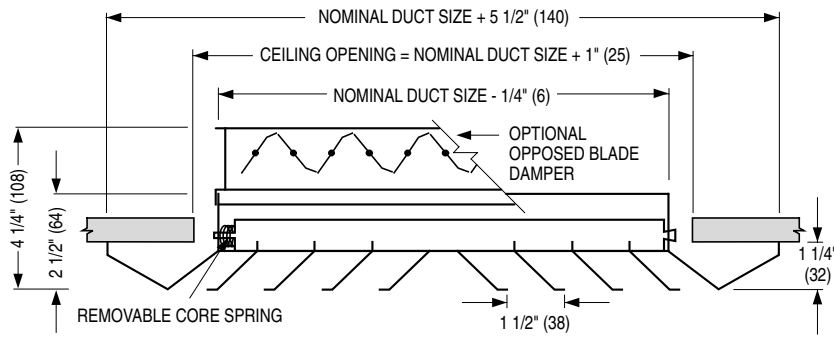
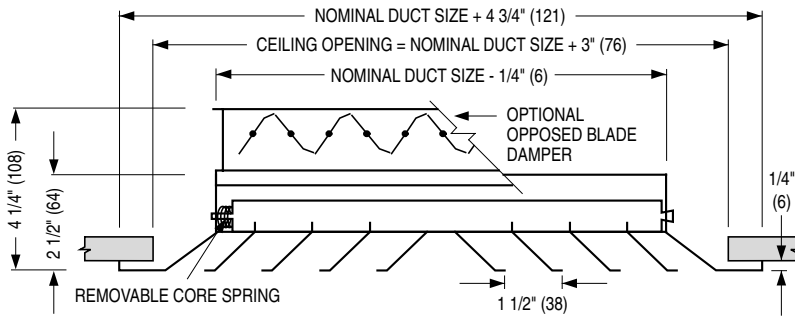

SPLINE TYPE DIFFUSER FOR ONE-DIRECTIONAL EXPOSED T-BAR LAY-IN GRID OR FOR CONCEALED T-BAR GRID.
(SPLINES ON TWO OPPOSITE SIDES. STEEL LIFT BRACKETS ON THE OTHER TWO SIDES).

Type S - Surface Mount Frame



Type B - Beveled Drop Face Frame



Type L - Lay-In T-Bar Frame

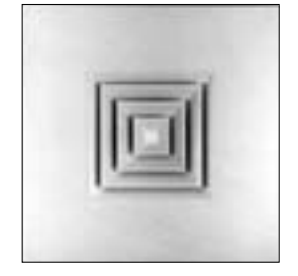

Type SP - Spline Frame

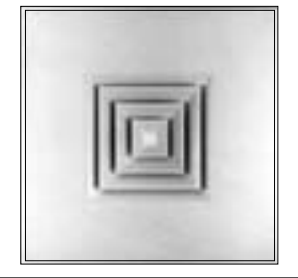

D

CEILING DIFFUSERS

Extended Panel Diffusers

Frame Types L, SP, TL, M and F

If the ceiling module is more than 3" (76) larger than the neck size of the diffuser in either or both dimensions, a module-sized extended panel will be added.

See the table at right for the maximum duct size for each module size.

TABLE 1

Ceiling Module Size	Maximum Duct Size Frames L, SP and M	Maximum Duct Size Frames TL and F
12 x 12 (305 x 305)	9 x 9 (229 x 229)	6 x 6 (152 x 152)
20 x 20 (508 x 508)	15 x 15 (381 x 381)	—
24 x 12 (610 x 305)	21 x 9 (533 x 229)	18 x 6 (457 x 152)
24 x 24 (610 x 610)	21 x 21 (533 x 533)	18 x 18 (457 x 457)
48 x 24 (1219 x 610)	45 x 21 (1143 x 533)	—

Dimensions are in inches (mm).

Dimensional Data and Frame Types Model Series 6500 and 6200

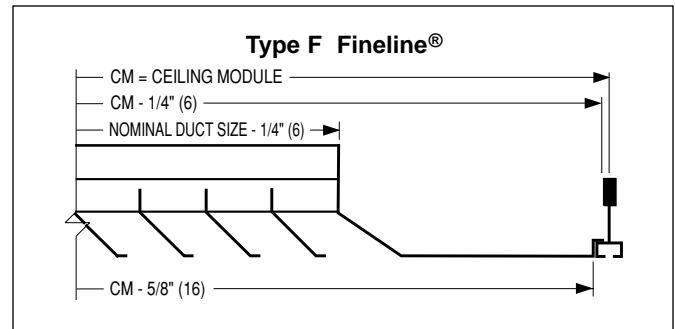
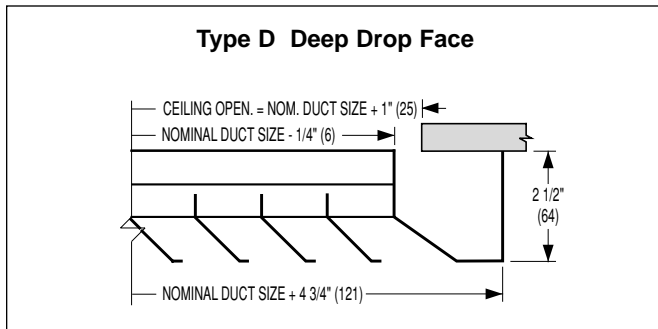
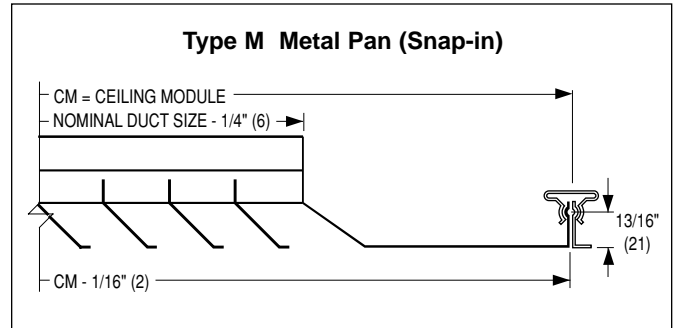
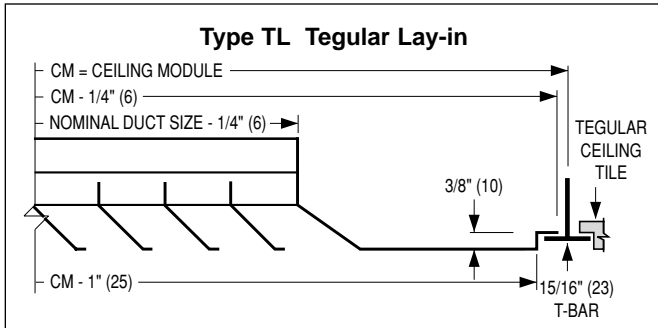

Adjustable Discharge Pattern Models 6550 & 6250

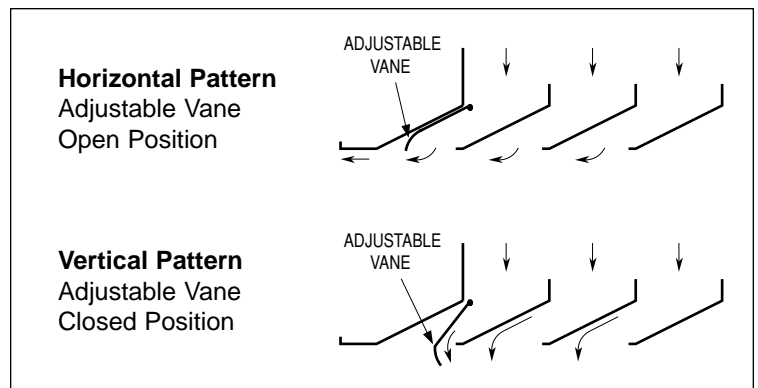

Models 6550 and 6250 Adjustable Diffusers provide continuous adjustment – from horizontal to vertical – on each face of the diffuser. They feature four hinged, independently adjustable control vanes attached to the outer cone.

FEATURES:

- Unit size is determined by duct 24" x 24" (610 x 610) neck size.
- Square duct sizes are recommended.
- Discharge patterns on all sides are independently adjustable.
- No tools required to adjust pattern.
- Can be adjusted from diffuser face without removing core.
- Square or rectangular 1, 2, 3 or 4-way core style diffusers up to and including

REMOVABLE CORE

- Standard feature of **Models 6500, 6550, 6200 and 6250.**
- Engineered design allows easy removal without the need for tools, yet remains securely in place.

HOW TO REMOVE "REMOVABLE" CORE

To remove diffuser core, lift the complete core assembly to disengage the latch, push the core against the core spring, pull down the core slightly and remove. Reverse procedure to re-install.

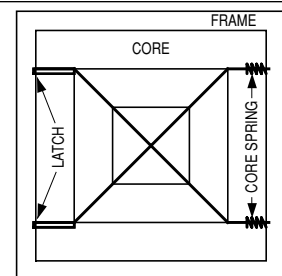

D
CEILING DIFFUSERS

Standard Core Styles Model Series 6500 and 6200

Contact factory for special core configurations.

SIZES AVAILABLE

	SQUARE	RECTANGULAR	CORE	MINIMUM	MAXIMUM			
→ 1-WAY			1S 1A 1B	6 x 6 (152 x 152) 9 x 6 (229 x 152) 9 x 6 (229 x 152)	36 x 36 (914 x 914) 36 x 33 (914 x 838) 36 x 33 (914 x 838)			
	↕ 2-WAY		2S 2A 2B	6 x 6 (152 x 152) 9 x 6 (229 x 152) 9 x 6 (229 x 152)	36 x 36 (914 x 914) 36 x 33 (914 x 838) 36 x 33 (914 x 838)			
			↻ 2-WAY CORNER		2G 2C 2D 2E 2F	6 x 6 (152 x 152) 9 x 6 (229 x 152) 9 x 6 (229 x 152) 9 x 6 (229 x 152) 9 x 6 (229 x 152)	36 x 36 (914 x 914) 36 x 33 (914 x 838) 36 x 33 (914 x 838) 36 x 33 (914 x 838) 36 x 33 (914 x 838)	
↕↔ 3-WAY		3A 3A1 3A2 3B 3C 3E 3H			6 x 6 (152 x 152) 9 x 6 (229 x 152) 9 x 6 (229 x 152) 12 x 6 (305 x 152) 9 x 6 (229 x 152) 15 x 6 (381 x 152) 6 x 6 (152 x 152)	36 x 36 (914 x 914) 36 x 33 (914 x 838) 36 x 33 (914 x 838) 36 x 18 (914 x 457) 36 x 33 (914 x 838) 36 x 15 (914 x 381) 36 x 36 (914 x 914)		
		↕↕ 4-WAY				4A 4B 4C 4E	6 x 6 (152 x 152) 9 x 6 (229 x 152) 12 x 6 (305 x 152) 15 x 6 (381 x 152)	36 x 36 (914 x 914) 36 x 33 (914 x 838) 36 x 30 (914 x 762) 36 x 27 (914 x 686)

Dimensions are in inches (mm).

Notes:

1. Duct sizes are available in 3" (76) increments.
2. Unless otherwise specified, the "x" dimension on 3C and 4E patterns will be such that cataloged flow division is obtained.
3. Patterns are shown in plan view (looking down into inlet).

D

CEILING DIFFUSERS

HOW TO SPECIFY OR TO ORDER

(Show complete Model Number and Size, unless "Default" is desired).

Pattern Ceiling Diffusers – Model Series 6500 and 6200

6500 - O - 9 x 9 - 24 x 24 - L - AW - 4A - SR08

MODEL

Steel	
- Fixed Pattern	6500
- Adjustable Pattern	6550
Aluminum	
- Fixed Pattern	6200
- Adjustable Pattern	6250

DAMPER

- No Damper (default)	—
- Opposed Blade (steel)	O
- Opposed Blade (alum.)	OA

NECK SIZE (W x H)

PANEL SIZE (TYPES L, SP, M, TL, F AND DL ONLY)

Imperial (inches)	Metric (mm)
- 12 x 12	300 x 300
- 20 x 20	500 x 500
- 24 x 12	600 x 300
- 24 x 24	600 x 600
- 48 x 24	1200 x 600

FRAME TYPE

- Surface Mount Flat	S
- T-Bar Lay-In	L
- Spline	SP
- Surface Mount Beveled	B
- Metal Pan	M
- Tegular (Drop Face)	TL
- Fineline®	F
- Surface Mount (Deep Drop)	D
- Dropped Face Lay-in	DL

Note:

1. Consult text as to limitations of panel, neck size and core style combinations.

ACCESSORIES

- None (default)	—
- Square to Round Transition Collar (04 thru 20 specify)	SR
- Earthquake Tabs	EQT

AIR BALANCING DEVICES

Rectangular Neck:	
- Equalizing Grid (long)	EGL
- Equalizing Grid (short)	EGS
- Damper/Equal. Grid (long)	DEGL
- Damper/Equal. Grid (short)	DEGS

Round Neck:	
- Radial Sliding Blade Damper	4250
- Radial Opposed Blade Damper	4275
- Butterfly Damper	4675
- Equalizing Grid	EGR
- Damper/Equalizing Grid	DEGR

CORE STYLE (See Below).

FINISH

- Appliance White (default)	AW
- Aluminum	AL
- Special Custom Color	SP

CORE STYLE CHART

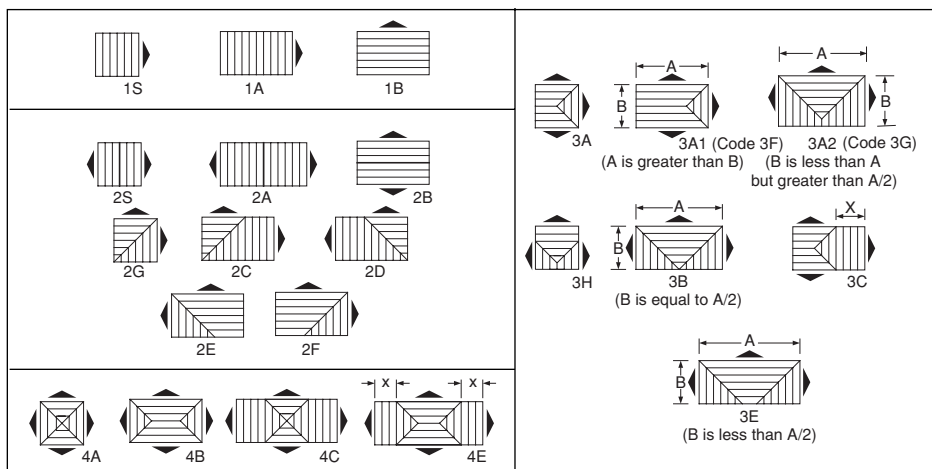

D
CEILING DIFFUSERS

SUGGESTED SPECIFICATION:

Furnish and install **Nailor Model** (select one) **6500/6550** (steel) or **6200/6250** (aluminum) **Pattern Ceiling Diffusers** of the sizes and capacities as shown on the plans and air distribution schedules. Model 6500 or 6200 shall incorporate fixed pattern discharge louvers for a horizontal throw pattern. Model 6550 or 6250 shall incorporate fixed pattern discharge louvers and adjustable vanes for a vertical or horizontal throw pattern. The entire core assembly shall be removable without the use of tools. The directional pattern shall be supplied as a 4, 3, 2, or 1-way discharge pattern as specified. The core is to be interchangeable with all other frame styles of equal size. The square or rectangular duct connection collar shall be an integral part of the frame assembly. The finish shall be AW Appliance White baked enamel (optional finishes are available).

(Optional) An opposed blade damper constructed of heavy gauge corrosion-resistant steel (aluminum is optional) shall be provided with all units

The manufacturer shall provide published performance data for the diffuser, which shall be tested in accordance with ANSI/ASHRAE Standard 70 – 1991.

Performance Data

Models 6500 and 6200 • Square Neck

D
CEILING DIFFUSERS

NOMINAL NECK SIZE	BLOW PATTERNS	NECK VELOCITY TP	300 .033		400 .058		500 .090		600 .130		700 .177		800 .231		900 .293	
			CFM NC	A	B	A	B	A	B	A	B	A	B	A	B	A
6 x 6 .25 SQ. FT.	RETURN FACTORS	—SP=1.1 TP NC + 1	75 —													
	4A	CFM/SIDE THROW, FT.	19 4-5-8		25 4-6-10		31 6-8-10		37 6-8-11		44 8-9-12		50 8-9-12		56 9-10-13	
	3A	CFM/SIDE THROW, FT.	19 28 4-5-8 5-8-11		25 38 4-6-10 6-9-12		31 47 6-8-10 8-10-14		37 56 6-8-11 8-11-15		44 66 8-9-12 9-12-16		50 75 8-9-12 9-12-17		56 85 9-10-13 10-13-18	
	2S 2G	CFM/SIDE THROW, FT.	37 8-9-12		50 9-10-14		62 10-11-16		75 11-12-17		88 12-13-18		100 12-13-19		113 12-14-20	
	1S	CFM/SIDE THROW, FT.	75 9-11-15		100 10-12-17		125 11-14-19		150 12-15-22		175 13-16-22		200 14-17-24		225 15-18-25	
9 x 9 .56 SQ. FT.	RETURN FACTORS	—SP=1.2 TP NC + 2	170 —		225 14		280 20		340 26		395 31		450 35		505 38	
	4A	CFM/SIDE THROW, FT.	42 6-8-12		56 7-10-14		70 10-11-15		84 10-12-16		98 11-12-17		112 11-14-19		126 12-15-20	
	3A	CFM/SIDE THROW, FT.	42 63 6-8-12 9-11-14		56 85 7-10-14 10-12-17		70 106 10-11-15 11-13-19		84 127 10-12-16 12-14-20		98 148 11-12-17 13-15-21		112 169 11-14-19 13-16-22		126 190 12-15-20 14-18-24	
	2S 2G	CFM/SIDE THROW, FT.	84 9-10-15		112 11-13-18		141 12-15-20		169 13-16-22		197 14-17-23		225 15-18-25		253 16-19-28	
	1S	CFM/SIDE THROW, FT.	169 12-15-20		225 14-17-23		282 16-19-26		338 17-22-29		394 18-22-31		450 19-24-33		507 22-25-35	
12 x 12 1.0 SQ. FT.	RETURN FACTORS	—SP=1.3 TP NC + 4	300 10		400 17		500 23		600 28		700 33		800 36		900 39	
	4A	CFM/SIDE THROW, FT.	75 8-13-15		100 11-14-18		125 13-15-21		150 14-17-22		175 14-18-24		200 15-20-25		225 17-21-27	
	3A	CFM/SIDE THROW, FT.	75 112 8-13-15 11-14-19		100 150 11-14-18 12-15-21		125 187 13-15-21 14-17-24		150 225 14-17-22 15-19-26		175 262 14-18-24 16-20-27		200 300 15-20-25 17-21-30		225 338 17-21-27 19-22-31	
	2S 2G	CFM/SIDE THROW, FT.	150 12-15-20		200 15-17-25		250 17-19-27		300 18-20-29		350 19-21-31		400 20-25-34		450 21-25-36	
	1S	CFM/SIDE THROW, FT.	300 16-20-28		400 18-22-32		500 21-25-37		600 22-26-39		700 23-28-41		800 25-29-41		900 28-33-47	
15 x 15 1.56 SQ. FT.	RETURN FACTORS	—SP=1.8 TP NC + 4	465 10		625 19		780 25		935 30		1090 33		1250 39		1400 41	
	4A	CFM/SIDE THROW, FT.	117 13-16-21		156 14-18-24		195 16-19-27		234 18-21-29		273 19-22-30		312 20-24-33		350 21-26-35	
	3A	CFM/SIDE THROW, FT.	117 175 13-16-21 14-17-23		156 234 14-18-24 17-19-29		195 292 16-19-27 19-22-31		234 351 18-21-29 21-23-34		273 409 19-22-30 22-25-36		312 468 19-24-35 22-29-39		350 527 21-26-35 25-29-42	
	2S 2G	CFM/SIDE THROW, FT.	234 16-20-27		312 19-22-31		390 21-25-36		468 22-27-40		546 24-29-42		625 27-31-45		700 27-35-47	
	1S	CFM/SIDE THROW, FT.	467 21-25-36		625 23-29-42		780 26-32-47		935 29-36-51		1090 30-39-55		1250 32-42-57		1400 36-44-61	
18 x 18 2.25 SQ. FT.	RETURN FACTORS	—SP=2.1 TP NC + 6	675 12		900 21		1125 27		1350 31		1575 36		1800 39		2025 42	
	4A	CFM/SIDE THROW, FT.	168 15-19-25		225 17-20-29		281 19-24-32		337 20-25-36		394 22-27-37		450 24-29-41		506 25-31-43	
	3A	CFM/SIDE THROW, FT.	168 253 15-19-25 17-22-29		225 338 17-20-29 20-25-33		281 422 19-24-32 23-27-38		337 506 20-25-36 25-32-42		394 590 22-27-37 26-32-45		450 675 24-29-41 27-35-48		506 760 25-31-43 32-36-51	
	2S 2G	CFM/SIDE THROW, FT.	337 19-23-32		450 22-26-38		562 24-30-43		675 26-31-46		787 30-34-49		900 30-35-53		1012 32-39-55	
	1S	CFM/SIDE THROW, FT.	675 25-33-45		900 30-36-51		1125 34-42-58		1350 36-45-61		1575 39-48-66		1800 43-52-70		2025 46-55-75	

For performance notes, see page D31.

Performance Data

Models 6500 and 6200 • Square Neck

NOMINAL NECK SIZE	BLOW PATTERNS	NECK VELOCITY TP	300 .033	400 .058	500 .090	600 .130	700 .177	800 .231	900 .293
21 x 21 3.06 SQ. FT.	RETURN FACTORS —SP=2.6 TP NC + 8	CFM NC	915 14	1225 22	1530 28	1835 32	2140 37	2450 40	2750 43
	4A	CFM/SIDE THROW, FT.	230 18-21-30	306 19-25-34	382 21-28-39	460 23-30-41	535 25-32-44	612 26-34-46	688 28-39-51
	3A	CFM/SIDE THROW, FT.	230 345 15-19-26 20-25-34	306 460 17-22-29 23-28-39	382 573 19-25-34 26-31-45	460 688 20-26-36 28-34-50	535 802 22-28-39 29-36-53	612 918 23-29-40 34-39-56	688 1030 25-34-45 34-43-59
	2S 2G	CFM/SIDE THROW, FT.	458 22-27-39	612 25-31-45	765 28-35-50	917 31-39-55	1070 32-42-59	1225 35-45-62	1375 39-48-66
1S	CFM/SIDE THROW, FT.	917 29-37-51	1225 34-43-59	1530 39-50-67	1835 43-53-71	2140 46-56-77	2450 50-60-82	2750 53-64-88	
24 x 24 4.0 SQ. FT.	RETURN FACTORS —SP=2.7 TP NC + 8	CFM NC	1200 15	1600 23	2000 29	2400 33	2800 37	3200 41	3600 44
	4A	CFM/SIDE THROW, FT.	300 20-24-33	400 24-27-40	500 27-31-44	600 29-33-47	700 31-35-51	800 33-40-55	900 35-40-58
	3A	CFM/SIDE THROW, FT.	300 450 20-24-33 23-28-39	400 600 24-27-40 26-31-46	500 750 27-31-44 29-36-52	600 900 29-33-47 31-38-56	700 1050 31-33-51 36-41-59	800 1200 33-40-55 36-43-64	900 1350 35-40-58 39-47-67
	2S 2G	CFM/SIDE THROW, FT.	600 25-33-45	800 30-36-51	1000 34-42-58	1200 36-45-61	1400 39-48-66	1600 43-52-70	1800 46-55-75
1S	CFM/SIDE THROW, FT.	1200 35-40-59	1600 38-48-67	2000 45-54-77	2400 48-58-82	2800 51-62-90	3200 54-67-93	3600 59-70-101	
30 x 30 6.25 SQ. FT.	RETURN FACTORS —SP=3.1 TP NC + 8	CFM NC	1875 16	2500 24	3125 30	3750 35	4375 39	5000 42	5625 46
	4A	CFM/SIDE THROW, FT.	469 25-31-42	625 29-36-48	782 34-40-55	937 36-44-61	1093 38-46-65	1250 40-50-69	1406 46-52-73
	3A	CFM/SIDE THROW, FT.	469 703 25-31-42 28-34-49	625 938 29-36-48 32-39-57	782 1172 34-40-55 35-44-64	937 1405 36-44-61 39-49-69	1093 1640 38-46-65 41-49-74	1250 1875 40-50-69 44-57-78	1406 2110 46-52-73 49-60-83
	2S 2G	CFM/SIDE THROW, FT.	937 32-40-55	1250 37-47-63	1562 42-53-72	1875 47-57-77	2187 50-60-83	2500 53-65-88	2812 57-68-95
1S	CFM/SIDE THROW, FT.	1875 42-53-72	2500 49-60-83	3125 56-69-93	3750 60-72-102	4375 63-77-109	5000 69-83-116	5625 72-88-123	
36 x 36 9.0 SQ. FT.	RETURN FACTORS —SP=3.6 TP NC + 9	CFM NC	2700 18	3600 25	4500 31	5400 36	6300 40	7200 44	8100 48
	4A	CFM/SIDE THROW, FT.	675 30-37-51	900 34-41-57	1125 39-46-67	1350 41-51-74	1575 44-53-78	1800 51-57-83	2025 51-64-87
	3A	CFM/SIDE THROW, FT.	675 1010 30-37-51 34-44-60	900 1350 34-41-57 40-48-68	1125 1687 39-46-67 46-56-78	1350 2025 41-51-74 48-60-82	1575 2362 44-53-78 52-64-88	1800 2700 51-57-83 58-70-94	2025 3038 51-64-87 62-74-100
	2S 2G	CFM/SIDE THROW, FT.	1350 40-45-67	1800 43-54-76	2250 50-61-86	2700 54-65-92	3150 58-70-101	3600 61-76-104	4050 67-79-113
1S	CFM/SIDE THROW, FT.	2700 49-61-85	3600 59-70-99	4500 66-80-114	5400 72-85-122	6300 76-91-131	7200 82-97-142	8100 87-106-150	

For performance notes, see page D31.

D
CEILING DIFFUSERS

Performance Data

Models 6500 and 6200 • Rectangular Neck

NOMINAL NECK SIZE	BLOW PATTERNS	NECK VELOCITY TP	300 .033		400 .058		500 .090		600 .130		700 .177		800 .231		900 .293	
			CFM NC	110 —	150 14	185 20	225 25	260 29	300 33	335 37						
9 x 6 .375 SQ. FT.	RETURN FACTORS —SP=1.2 TP NC + 0	CFM NC	110 —		150 14		185 20		225 25		260 29		300 33		335 37	
	4B	CFM/SIDE THROW, FT.	37 18	50 25	62 31	75 37	87 44	100 50	112 56							
	3A1	CFM/SIDE THROW, FT.	47 18	62 25	78 31	94 37	109 44	125 50	140 56							
	3A2	CFM/SIDE THROW, FT.	42 35	55 47	70 58	84 70	98 82	112 94	126 105							
	2A 2B	CFM/SIDE THROW, FT.	56	75	93	112	131	150	168							
	2C 2E 2D 2F	CFM/SIDE THROW, FT.	75 37	100 50	125 62	150 75	175 87	200 100	225 112							
1A 1B	CFM/SIDE THROW, FT.	112	150	187	225	262	300	337								
12 x 6 .50 SQ. FT.	RETURN FACTORS —SP=1.6 TP NC + 1	CFM NC	150 —		200 14		250 20		300 26		350 31		400 35		450 39	
	4B 4C	CFM/SIDE THROW, FT.	56 18	75 25	94 31	113 37	131 44	150 50	169 56							
	3A1	CFM/SIDE THROW, FT.	66 18	87 25	109 31	131 37	153 44	175 50	197 56							
	3B	CFM/SIDE THROW, FT.	75 37	100 50	126 62	150 75	176 87	200 100	226 112							
	2A 2B	CFM/SIDE THROW, FT.	75	100	125	150	175	200	225							
	2C 2E 2D 2F	CFM/SIDE THROW, FT.	112 37	150 50	188 62	225 75	263 87	300 100	338 112							
1A 1B	CFM/SIDE THROW, FT.	150	200	250	300	350	400	450								
15 x 6 .625 SQ. FT.	RETURN FACTORS —SP=1.9 TP NC + 1	CFM NC	190 —		250 15		310 21		375 27		440 32		500 36		565 40	
	4B 4C	CFM/SIDE THROW, FT.	75 18	100 25	125 31	150 37	175 44	200 50	225 56							
	4E	CFM/SIDE THROW, FT.	56 37	75 50	94 62	113 75	131 87	150 100	169 112							
	3A1	CFM/SIDE THROW, FT.	84 18	112 25	140 31	169 37	197 44	225 50	253 56							
	2A 2B	CFM/SIDE THROW, FT.	94	125	156	187	219	250	281							
	2C 2E 2D 2F	CFM/SIDE THROW, FT.	150 37	200 50	250 62	300 75	350 87	400 100	450 112							
1A 1B	CFM/SIDE THROW, FT.	188	250	312	375	438	500	563								

Notes:

- Core style 4E is sized to give equal flow as near as possible in directions A and B.
- For core styles 1A, 1B, 2A and 2B, the "A" direction is shown. Throw correction factor for "B" direction is: $A \times .82 = B$.

For performance notes, see page D31.

D
CEILING DIFFUSERS

Performance Data

Models 6500 and 6200 • Rectangular Neck

NOMINAL NECK SIZE	BLOW PATTERNS	NECK VELOCITY TP	300 .033		400 .058		500 .090		600 .130		700 .177		800 .231		900 .293	
			CFM NC	225 —	300 16	375 22	450 28	525 33	600 37	675 41						
18 x 6 .75 SQ. FT.	RETURN FACTORS —SP=2.6 TP NC + 2	CFM NC	225 —		300 16		375 22		450 28		525 33		600 37		675 41	
	4B 4C	CFM/SIDE THROW, FT.	94 18	125 25	156 31	188 37	218 44	250 50	281 56							
	4E	CFM/SIDE THROW, FT.	56 56	75 75	94 94	113 113	131 131	150 150	169 169							
	3A1	CFM/SIDE THROW, FT.	103 18	137 25	172 31	206 37	240 44	275 50	309 56							
	2A 2B	CFM/SIDE THROW, FT.	112 13-16-22	150 16-18-26	187 18-20-29	225 19-22-31	262 20-23-34	300 22-26-36	337 23-26-38							
	2C 2E 2D 2F	CFM/SIDE THROW, FT.	187 37	250 50	313 62	375 75	438 87	500 100	563 112							
1A 1B	CFM/SIDE THROW, FT.	225 17-21-29	300 19-23-32	375 22-26-38	450 23-29-42	525 25-30-44	600 29-32-47	675 29-36-52								
21 x 6 .875 SQ. FT.	RETURN FACTORS —SP=3.2 TP NC + 3	CFM NC	260 —		350 16		435 22		525 29		610 33		700 38		785 41	
	4B 4C	CFM/SIDE THROW, FT.	112 18	150 25	187 31	225 37	262 44	300 50	337 56							
	4E	CFM/SIDE THROW, FT.	75 56	100 75	125 94	150 113	175 131	200 150	225 169							
	3A1	CFM/SIDE THROW, FT.	122 18	162 25	203 31	244 37	284 44	325 50	365 56							
	2A 2B	CFM/SIDE THROW, FT.	131 13-16-22	175 16-18-26	218 18-20-29	262 19-22-31	306 20-23-34	350 22-26-36	393 23-26-38							
	2C 2E 2D 2F	CFM/SIDE THROW, FT.	225 37	300 50	375 62	450 75	525 87	600 100	675 112							
1A 1B	CFM/SIDE THROW, FT.	262 17-21-29	350 19-23-32	437 22-26-38	525 23-29-42	612 25-30-44	700 29-32-47	787 29-36-49								
24 x 6 1.0 SQ. FT.	RETURN FACTORS —SP=3.9 TP NC + 4	CFM NC	300 —		400 16		500 23		600 30		700 34		800 39		900 42	
	4B 4C	CFM/SIDE THROW, FT.	131 18	175 25	219 31	263 37	306 44	350 50	394 56							
	4E	CFM/SIDE THROW, FT.	75 75	100 100	125 125	150 150	175 175	200 200	225 225							
	3A1	CFM/SIDE THROW, FT.	141 18	187 25	234 31	281 37	328 44	375 50	422 56							
	2A 2B	CFM/SIDE THROW, FT.	150 13-16-22	200 16-18-26	250 18-20-29	300 19-22-31	350 20-23-34	400 22-26-36	450 23-26-38							
	2C 2E 2D 2F	CFM/SIDE THROW, FT.	260 37	350 50	438 62	525 75	613 87	700 100	788 112							
1A 1B	CFM/SIDE THROW, FT.	300 18-22-31	400 21-25-36	500 23-29-42	600 25-30-44	700 29-32-47	800 29-34-51	900 31-38-53								

Notes:

1. Core style 4E is sized to give equal flow as near as possible in directions A and B.
2. For core styles 1A, 1B, 2A and 2B, the "A" direction is shown. Throw correction factor for "B" direction is: A x .82 = B.

For performance notes, see page D31.

Performance Data

Models 6500 and 6200 • Rectangular Neck

NOMINAL NECK SIZE	BLOW PATTERNS	NECK VELOCITY TP	300 .033		400 .058		500 .090		600 .130		700 .177		800 .231		900 .293	
			CFM NC	A	B	A	B	A	B	A	B	A	B	A	B	A
30 x 6 1.25 SQ. FT.	RETURN FACTORS —SP=3.2 TP NC + 3	CFM NC	375 —		500 17		625 24		750 30		875 35		1000 40		1125 43	
	4B 4C	CFM/SIDE THROW, FT.	169	18	225	25	281	31	338	37	393	44	450	50	506	56
	4E	CFM/SIDE THROW, FT.	94	94	125	125	156	156	188	188	219	219	250	250	282	282
	3A1	CFM/SIDE THROW, FT.	178	18	237	25	297	31	356	37	415	44	475	50	534	56
	2A 2B	CFM/SIDE THROW, FT.	187		250		312		375		437		500		562	
	2C 2D 2E 2F	CFM/SIDE THROW, FT.	337	37	450	50	563	62	675	75	788	87	900	100	1013	112
1A 1B	CFM/SIDE THROW, FT.	375		500		625		750		875		1000		1125		
12 x 9 .75 SQ. FT.	RETURN FACTORS —SP=3.9 TP NC + 4	CFM NC	225 —		300 17		375 23		450 28		525 33		600 36		675 40	
	4B 4C	CFM/SIDE THROW, FT.	70	42	94	56	117	70	141	84	164	98	188	112	211	126
	3A1	CFM/SIDE THROW, FT.	91	42	121	56	152	70	183	84	213	98	244	112	274	126
	3A2	CFM/SIDE THROW, FT.	75	75	100	100	125	125	150	150	175	175	200	200	225	225
	2A 2B	CFM/SIDE THROW, FT.	112		150		187		225		262		300		337	
	2C 2D 2E 2F	CFM/SIDE THROW, FT.	141	84	188	112	234	141	281	169	328	197	375	225	422	253
1A 1B	CFM/SIDE THROW, FT.	225		300		375		450		525		600		675		
15 x 9 .93 SQ. FT.	RETURN FACTORS —SP=1.7 TP NC + 3	CFM NC	280 —		375 18		470 24		565 29		655 34		750 37		845 41	
	4B 4C	CFM/SIDE THROW, FT.	98	42	131	56	165	70	198	84	230	98	263	112	296	126
	4E	CFM/SIDE THROW, FT.	70	70	94	94	117	117	141	141	164	164	188	188	211	211
	3A1	CFM/SIDE THROW, FT.	120	42	159	56	200	70	240	84	279	98	319	112	359	126
	3A2	CFM/SIDE THROW, FT.	117	82	155	110	196	137	233	165	272	192	312	219	351	247
	2A 2B	CFM/SIDE THROW, FT.	140		187		235		281		328		375		422	
2C 2D 2E 2F	CFM/SIDE THROW, FT.	197	84	263	112	329	141	394	169	459	197	525	225	592	253	
1A 1B	CFM/SIDE THROW, FT.	281		375		470		563		656		750		845		

Notes:

1. Core style 4E is sized to give equal flow as near as possible in directions A and B.
2. For core styles 1A, 1B, 2A and 2B, the "A" direction is shown. Throw correction factor for "B" direction is: A x .82 = B.

For performance notes, see page D31.

Performance Data

Models 6500 and 6200 • Rectangular Neck

NOMINAL NECK SIZE	BLOW PATTERNS	NECK VELOCITY TP	300 .033		400 .058		500 .090		600 .130		700 .177		800 .231		900 .293	
			CFM NC	CFM NC	CFM NC	CFM NC	CFM NC	CFM NC	CFM NC	CFM NC	CFM NC	CFM NC	CFM NC	CFM NC	CFM NC	
18 x 9 1.125 SQ. FT.	RETURN FACTORS —SP=2.1 TP NC + 3	CFM NC	335 —		450 19		560 25		675 30		790 35		900 38		1010 42	
	4B 4C	CFM/SIDE THROW, FT.	126 42	169 56	211 70	254 84	296 98	338 112	380 126							
	4E	CFM/SIDE THROW, FT.	99 70	132 94	164 117	197 141	230 164	263 188	296 211							
	3A1	CFM/SIDE THROW, FT.	147 42	197 56	246 70	295 84	345 98	394 112	443 126							
	3B	CFM/SIDE THROW, FT.	168 84	225 112	281 141	337 169	394 197	450 225	506 253							
	2A 2B	CFM/SIDE THROW, FT.	163	225	281	337	394	450	506							
	2C 2E 2D 2F	CFM/SIDE THROW, FT.	253 84	338 112	421 141	506 169	591 197	675 225	759 253							
1A 1B	CFM/SIDE THROW, FT.	337	450	562	675	788	900	1012								
21 x 9 1.125 SQ. FT.	RETURN FACTORS —SP=2.5 TP NC + 4	CFM NC	395 —		525 19		655 25		785 31		915 36		1050 38		1180 42	
	4B 4C	CFM/SIDE THROW, FT.	154 42	206 56	258 70	309 84	360 98	413 112	464 126							
	4E	CFM/SIDE THROW, FT.	98 98	131 131	163 163	196 196	229 229	261 261	294 294							
	3A1	CFM/SIDE THROW, FT.	175 42	234 56	292 70	351 84	410 98	468 112	527 126							
	2A 2B	CFM/SIDE THROW, FT.	196	262	327	393	458	525	590							
	2C 2E 2D 2F	CFM/SIDE THROW, FT.	308 84	412 112	514 141	617 169	720 197	825 225	927 253							
	1A 1B	CFM/SIDE THROW, FT.	393	524	655	786	917	1050	1180							
24 x 9 1.5 SQ. FT.	RETURN FACTORS —SP=2.9 TP NC + 4	CFM NC	450 —		600 19		750 25		900 31		1050 36		1200 38		1350 43	
	4B 4C	CFM/SIDE THROW, FT.	183 42	244 56	305 70	366 84	427 98	488 112	549 126							
	4E	CFM/SIDE THROW, FT.	126 99	169 132	211 164	253 197	295 230	337 263	379 296							
	3A1	CFM/SIDE THROW, FT.	204 42	272 56	340 70	408 84	476 98	544 112	612 126							
	2A 2B	CFM/SIDE THROW, FT.	225	300	375	450	525	600	675							
	2C 2E 2D 2F	CFM/SIDE THROW, FT.	365 84	488 112	609 141	731 169	853 197	975 225	1097 253							
	1A 1B	CFM/SIDE THROW, FT.	450	600	750	900	1050	1200	1350							

Notes:

1. Core style 4E is sized to give equal flow as near as possible in directions A and B.
2. For core styles 1A, 1B, 2A and 2B, the "A" direction is shown. Throw correction factor for "B" direction is: A x .82 = B.

For performance notes, see page D31.

D

CEILING DIFFUSERS

Performance Data

Models 6500 and 6200 • Rectangular Neck

NOMINAL NECK SIZE	BLOW PATTERNS	NECK VELOCITY TP	300 .033		400 .058		500 .090		600 .130		700 .177		800 .231		900 .293	
			CFM NC	— —	CFM NC	— —	CFM NC	— —	CFM NC	— —	CFM NC	— —	CFM NC	— —	CFM NC	— —
30 x 9 1.875 SQ. FT.	RETURN FACTORS —SP=3.9 TP NC + 5	CFM NC	560 —		750 20		935 26		1125 32		1310 37		1500 39		1685 44	
	4B 4C	CFM/SIDE THROW, FT.	238 42	319 56	398 70	478 84	557 98	638 112	716 126							
	4E	CFM/SIDE THROW, FT.	155 126	206 169	258 211	310 253	361 295	413 337	465 379							
	3A1	CFM/SIDE THROW, FT.	259 42	347 56	433 70	520 84	606 98	694 112	779 126							
	2A 2B	CFM/SIDE THROW, FT.	281	375	468	562	655	750	842							
	2C 2E 2D 2F	CFM/SIDE THROW, FT.	476 84	638 112	796 141	956 169	1113 197	1275 225	1432 253							
	1A 1B	CFM/SIDE THROW, FT.	562	750	937	1125	1310	1500	1685							
36 x 9 2.25 SQ. FT.	RETURN FACTORS —SP=5.0 TP NC + 6	CFM NC	675 —		900 21		1125 27		1350 33		1575 38		1800 40		2025 44	
	4B 4C	CFM/SIDE THROW, FT.	295 42	394 56	492 70	591 84	689 98	788 112	886 126							
	4E	CFM/SIDE THROW, FT.	183 155	244 206	305 258	366 310	427 361	488 413	549 465							
	3A1	CFM/SIDE THROW, FT.	316 42	422 56	527 70	633 84	738 98	844 112	949 126							
	2A 2B	CFM/SIDE THROW, FT.	337	450	562	675	787	900	1012							
	2C 2E 2D 2F	CFM/SIDE THROW, FT.	590 84	788 112	984 141	1181 169	1378 197	1575 225	1772 253							
	1A 1B	CFM/SIDE THROW, FT.	675	900	1125	1350	1575	1800	2025							
15 x 12 1.25 SQ. FT.	RETURN FACTORS —SP=1.6 TP NC + 2	CFM NC	375 —		500 19		625 25		750 30		875 34		1000 38		1125 41	
	4B 4C	CFM/SIDE THROW, FT.	112 75	150 100	187 125	225 150	262 175	300 200	337 225							
	3A1	CFM/SIDE THROW, FT.	150 75	200 100	250 125	300 150	350 175	400 200	450 225							
	3A2	CFM/SIDE THROW, FT.	117 129	156 172	195 215	234 258	273 301	312 344	351 387							
	2A 2B	CFM/SIDE THROW, FT.	187	250	312	375	437	500	567							
	2C 2E 2D 2F	CFM/SIDE THROW, FT.	225 150	300 200	375 250	450 300	525 350	600 400	675 450							
	1A 1B	CFM/SIDE THROW, FT.	375	500	625	750	875	1000	1125							

Notes:

1. Core style 4E is sized to give equal flow as near as possible in directions A and B.
2. For core styles 1A, 1B, 2A and 2B, the "A" direction is shown. Throw correction factor for "B" direction is: A x .82 = B.

For performance notes, see page D31.

D
CEILING DIFFUSERS

Performance Data

Models 6500 and 6200 • Rectangular Neck

NOMINAL NECK SIZE	BLOW PATTERNS		NECK VELOCITY TP	300 .033		400 .058		500 .090		600 .130		700 .177		800 .231		900 .293	
	RETURN FACTORS	—SP=1.9 TP NC + 3		CFM NC	A	B	A	B	A	B	A	B	A	B	A	B	A
18 x 12 1.5 SQ. FT.			CFM/SIDE THROW, FT.	150	75	200	100	250	125	300	150	350	175	400	200	450	225
				15-18-25	8-13-15	18-21-31	11-14-18	21-24-34	13-15-21	22-25-36	14-17-22	24-27-39	14-18-24	25-31-42	15-20-25	27-31-45	17-21-27
				187	75	250	100	312	125	375	150	437	175	500	200	562	225
				17-21-28	8-13-15	20-24-32	11-14-18	22-27-36	13-15-21	24-31-41	14-17-22	25-31-43	14-18-24	27-34-46	15-20-25	31-35-49	17-21-27
				168	141	225	187	281	234	337	281	394	328	450	375	506	422
				14-17-24	13-15-21	15-20-27	14-17-24	17-22-31	15-20-27	18-24-32	17-21-31	20-25-35	18-22-31	21-27-36	20-24-34	22-31-41	21-25-35
21 x 12 1.75 SQ. FT.			CFM/SIDE THROW, FT.	187	75	250	100	312	125	375	150	437	175	500	200	562	225
				17-21-28	8-13-15	20-24-32	11-14-18	22-27-36	13-15-21	24-31-41	14-17-22	25-32-43	14-18-24	27-34-46	15-20-25	31-35-49	17-21-27
				150	112	200	150	250	187	300	225	350	262	400	300	450	337
				15-18-25		18-21-31	15-18-25	21-24-34		22-25-36		24-27-39		25-31-42	22-25-36	27-31-45	
				225	75	300	100	375	125	450	150	525	175	600	200	675	225
				18-22-31	8-13-15	21-25-35	11-14-18	24-28-41	13-15-21	25-31-45	14-17-22	27-32-48	14-18-24	29-35-50	15-20-25	31-39-53	17-21-27
24 x 12 2.0 SQ. FT.			CFM/SIDE THROW, FT.	225	75	300	100	375	125	450	150	525	175	600	200	675	225
				18-22-31	8-13-15	21-25-35	11-14-18	24-28-41	13-15-21	25-31-45	14-17-22	27-32-48	14-18-24	31-35-50	15-20-25	31-39-53	17-21-27
				150	150	200	200	250	250	300	300	350	350	400	400	450	450
				15-18-25	15-18-25	18-21-31	18-21-31	21-24-34	21-24-34	22-25-36	22-25-36	24-27-39	24-27-39	25-31-42	25-31-42	27-31-45	27-31-45
				262	75	350	100	437	175	525	150	612	175	700	200	787	225
				18-22-31	8-13-15	21-25-35	11-14-18	24-28-41	13-15-21	25-31-45	14-17-22	27-32-48	14-18-24	29-35-50	15-20-25	31-39-53	17-21-27

D
CEILING DIFFUSERS

Notes:

1. Core style 4E is sized to give equal flow as near as possible in directions A and B.
2. For core styles 1A, 1B, 2A and 2B, the "A" direction is shown. Throw correction factor for "B" direction is: $A \times .82 = B$.

For performance notes, see page D31.

Performance Data

Models 6500 and 6200 • Rectangular Neck

D
CEILING DIFFUSERS

NOMINAL NECK SIZE	BLOW PATTERNS	NECK VELOCITY TP	300 .033		400 .058		500 .090		600 .130		700 .177		800 .231		900 .293	
			CFM NC	750 15	1000 23	1250 29	1500 33	1750 37	2000 41	2250 43						
30 x 12 SQ. FT.	RETURN FACTORS —SP=3.3 TP NC + 6	CFM NC	750 15	1000 23	1250 29	1500 33	1750 37	2000 41	2250 43							
	4B 4C	CFM/SIDE THROW, FT.	300 75	400 100	500 125	600 150	700 175	800 200	900 225							
	4E	CFM/SIDE THROW, FT.	183 183	250 250	313 313	375 375	437 437	500 500	562 562							
	3A1	CFM/SIDE THROW, FT.	337 75	450 100	562 125	675 150	787 175	900 200	1012 225							
	2A 2B	CFM/SIDE THROW, FT.	375	500	625	750	875	1000	1125							
	2C 2E 2D 2F	CFM/SIDE THROW, FT.	600 150	800 200	1000 250	1200 300	1400 350	1600 400	1800 450							
	1A 1B	CFM/SIDE THROW, FT.	750	1000	1250	1500	1750	2000	2250							
36 x 12 SQ. FT.	RETURN FACTORS —SP=4.0 TP NC + 7	CFM NC	900 16	1200 25	1500 30	1800 34	2100 38	2400 42	2700 44							
	4B 4C	CFM/SIDE THROW, FT.	375 75	500 100	625 125	750 150	875 175	1000 200	1125 225							
	4E	CFM/SIDE THROW, FT.	225 225	300 300	375 375	450 450	525 525	600 600	675 675							
	3A1	CFM/SIDE THROW, FT.	412 75	550 100	687 125	825 150	962 175	1100 200	1237 225							
	2A 2B	CFM/SIDE THROW, FT.	450	600	750	900	1050	1200	1350							
	2C 2E 2D 2F	CFM/SIDE THROW, FT.	750 150	1000 200	1250 250	1500 300	1750 350	2000 400	2250 450							
	1A 1B	CFM/SIDE THROW, FT.	900	1200	1500	1800	2100	2400	2700							
18 x 15 SQ. FT.	RETURN FACTORS —SP=2.0 TP NC + 4	CFM NC	560 14	750 21	935 28	1125 32	1310 36	1500 39	1685 43							
	4B 4C	CFM/SIDE THROW, FT.	164 117	219 156	273 195	328 234	383 273	438 312	492 351							
	3A1	CFM/SIDE THROW, FT.	222 117	297 156	371 195	445 234	519 273	594 312	668 351							
	3A2	CFM/SIDE THROW, FT.	168 197	225 262	281 328	337 394	394 459	450 525	506 590							
	2A 2B	CFM/SIDE THROW, FT.	281	375	468	562	656	750	843							
	2C 2E 2D 2F	CFM/SIDE THROW, FT.	329 234	438 312	547 390	657 468	766 546	876 624	985 702							
	1A 1B	CFM/SIDE THROW, FT.	562	750	937	1125	1312	1500	1687							

Notes:

1. Core style 4E is sized to give equal flow as near as possible in directions A and B.
2. For core styles 1A, 1B, 2A and 2B, the "A" direction is shown. Throw correction factor for "B" direction is: A x .82 = B.

For performance notes, see page D31.

Performance Data

Models 6500 and 6200 • Rectangular Neck

NOMINAL NECK SIZE	BLOW PATTERNS	NECK VELOCITY TP	300 .033		400 .058		500 .090		600 .130		700 .177		800 .231		900 .293		
			CFM NC	655 14	875 21	1090 28	1310 33	1530 36	1750 39	1970 43							
21 x 15 2.185 SQ. FT.	RETURN FACTORS —SP=2.1 TP NC + 5	CFM NC	655 14		875 21		1090 28		1310 33		1530 36		1750 39		1970 43		
	4B 4C	CFM/SIDE THROW, FT.	210 117	281 156	361 195	422 234	493 273	563 312	634 351								
	4E	CFM/SIDE THROW, FT.	164 164	218 218	273 273	327 327	382 382	437 437	491 491								
	3A1	CFM/SIDE THROW, FT.	269 117	359 156	448 195	539 234	629 273	719 312	809 351								
	3A2	CFM/SIDE THROW, FT.	230 213	306 284	382 355	460 426	535 498	612 569	688 641								
	2A 2B	CFM/SIDE THROW, FT.	327 21-25-36	437 24-28-42	596 27-33-48	656 28-34-51	766 31-37-54	875 33-39-58	985 36-43-61								
	2C 2D 2E 2F	CFM/SIDE THROW, FT.	422 234	563 312	702 390	844 468	966 546	1126 624	1268 702								
	1A 1B	CFM/SIDE THROW, FT.	655 25-33-45	875 30-36-51	1092 33-42-58	1312 36-45-61	1532 39-48-66	1750 43-52-70	1970 46-55-75								
	24 x 15 2.5 SQ. FT.	RETURN FACTORS —SP=2.6 TP NC + 6	CFM NC	750 14		1000 22		1250 29		1500 34		1750 37		2000 39		2250 44	
		4B 4C	CFM/SIDE THROW, FT.	258 117	344 156	430 195	516 234	602 273	688 312	774 351							
4E		CFM/SIDE THROW, FT.	164 211	218 281	273 352	327 422	382 492	437 563	491 633								
3A1		CFM/SIDE THROW, FT.	316 117	422 156	527 195	633 234	738 273	844 312	949 351								
3A2		CFM/SIDE THROW, FT.	300 225	400 300	500 375	600 450	700 525	800 600	900 675								
2A 2B		CFM/SIDE THROW, FT.	375 22-27-37	500 25-33-45	625 28-36-51	750 31-39-54	875 33-42-58	1000 36-45-63	1125 37-48-66								
2C 2D 2E 2F		CFM/SIDE THROW, FT.	516 234	688 312	860 390	1032 468	1204 546	1376 624	1548 702								
1A 1B		CFM/SIDE THROW, FT.	750 27-33-48	1000 33-37-54	1250 36-43-61	1500 39-48-66	1750 41-51-70	2000 45-54-75	2250 48-57-79								
30 x 15 3.125 SQ. FT.		RETURN FACTORS —SP=3.1 TP NC + 7	CFM NC	935 14		1250 23		1565 30		1875 36		2190 39		2500 40		2810 45	
		4B 4C	CFM/SIDE THROW, FT.	351 117	469 156	587 195	703 234	822 273	938 312	1054 351							
	4E	CFM/SIDE THROW, FT.	258 211	344 281	430 352	516 422	602 492	688 583	775 633								
	3A1	CFM/SIDE THROW, FT.	410 117	547 156	685 195	820 234	958 273	1094 312	1224 351								
	3B	CFM/SIDE THROW, FT.	468 234	625 312	782 391	937 469	1095 547	1250 625	1406 702								
	2A 2B	CFM/SIDE THROW, FT.	468 22-27-39	625 25-31-45	782 28-35-50	937 31-39-55	1095 32-42-59	1250 35-45-62	1405 39-48-66								
	2C 2D 2E 2F	CFM/SIDE THROW, FT.	702 234	938 312	1175 390	1407 468	1644 546	1876 624	2108 702								
	1A 1B	CFM/SIDE THROW, FT.	937 28-36-49	1250 33-42-57	1565 37-48-64	1875 42-51-69	2190 45-54-75	2500 48-58-79	2810 51-61-85								

Notes:

1. Core style 4E is sized to give equal flow as near as possible in directions A and B.
2. For core styles 1A, 1B, 2A and 2B, the "A" direction is shown. Throw correction factor for "B" direction is: A x .82 = B.

For performance notes, see page D31.

D
CEILING DIFFUSERS

Performance Data

Models 6500 and 6200 • Rectangular Neck

NOMINAL NECK SIZE	BLOW PATTERNS	NECK VELOCITY TP	300 .033		400 .058		500 .090		600 .130		700 .177		800 .231		900 .293	
			CFM NC	1125 13	1500 23	1875 31	2250 37	2625 40	3000 41	3375 46						
36 x 15 3.75 SQ. FT.	RETURN FACTORS —SP=3.8 TP NC + 7	CFM NC	1125 13		1500 23		1875 31		2250 37		2625 40		3000 41		3375 46	
	4B 4C	CFM/SIDE THROW, FT.	446 117	594 156	742 195	891 234	1039 273	1188 312	1336 351							
	4E	CFM/SIDE THROW, FT.	306 258	408 344	510 430	612 516	714 602	816 688	918 775							
	3A1	CFM/SIDE THROW, FT.	504 117	672 156	840 195	1008 234	1176 273	1344 312	1512 351							
	2A 2B	CFM/SIDE THROW, FT.	562	750	937	1125	1312	1500	1682							
	2C 2E	CFM/SIDE THROW, FT.	890 234	1188 312	1485 390	1782 468	2079 546	2376 624	2873 702							
1A 1B	CFM/SIDE THROW, FT.	1125	1500	1875	2250	2625	3000	3375								
21 x 18 2.625 SQ. FT.	RETURN FACTORS —SP=2.2 TP NC + 5	CFM NC	785 14		1050 21		1310 27		1575 32		1840 36		2100 40		2360 43	
	4B 4C	CFM/SIDE THROW, FT.	225 169	300 225	375 280	450 337	526 394	600 450	674 506							
	3A1	CFM/SIDE THROW, FT.	309 169	412 225	514 281	619 337	723 394	825 450	927 506							
	3A2	CFM/SIDE THROW, FT.	279 230	372 306	464 382	557 460	652 535	744 612	836 688							
	2A 2B	CFM/SIDE THROW, FT.	393	525	655	787	920	1050	1180							
	2C 2E	CFM/SIDE THROW, FT.	450 338	600 450	750 560	900 675	1060 790	1200 900	1350 1010							
1A 1B	CFM/SIDE THROW, FT.	787	1050	1310	1575	1840	2100	2360								
24 x 18 3.0 SQ. FT.	RETURN FACTORS —SP=2.5 TP NC + 6	CFM NC	900 15		1200 22		1500 28		1800 33		2100 37		2400 40		2700 43	
	4B 4C	CFM/SIDE THROW, FT.	281 169	375 225	469 281	563 337	656 394	750 450	844 506							
	4E	CFM/SIDE THROW, FT.	225 225	300 300	375 375	450 450	525 525	600 600	675 675							
	3A1	CFM/SIDE THROW, FT.	366 169	487 225	609 281	731 337	853 394	975 450	1098 506							
	3A2	CFM/SIDE THROW, FT.	300 300	400 400	500 500	600 600	700 700	800 800	900 900							
	2A 2B	CFM/SIDE THROW, FT.	450	600	750	900	1050	1200	1350							
2C 2E	CFM/SIDE THROW, FT.	562 338	750 450	938 562	1125 675	1313 787	1500 900	1688 1012								
1A 1B	CFM/SIDE THROW, FT.	900	1200	1500	1800	2100	2400	2700								

Notes:

- Core style 4E is sized to give equal flow as near as possible in directions A and B.
- For core styles 1A, 1B, 2A and 2B, the "A" direction is shown. Throw correction factor for "B" direction is: $A \times .82 = B$.

For performance notes, see page D31.

Performance Data

Models 6500 and 6200 • Rectangular Neck

NOMINAL NECK SIZE	BLOW PATTERNS	NECK VELOCITY TP	300 .033		400 .058		500 .090		600 .130		700 .177		800 .231		900 .293	
			A	B	A	B	A	B	A	B	A	B	A	B	A	B
30 x 18 3.75 SQ. FT.	RETURN FACTORS —SP=3.1 TP NC + 7	CFM NC	1125 15		1500 23		1875 29		2250 34		2625 38		3000 42		3375 45	
	4B 4C	CFM/SIDE THROW, FT.	394	169	525	225	657	281	788	337	918	394	1050	450	1181	506
	4E	CFM/SIDE THROW, FT.	281	281	375	375	469	469	563	563	657	657	750	750	845	845
	3A1	CFM/SIDE THROW, FT.	478	169	637	225	797	281	956	337	1115	394	1275	450	1434	506
	3A2	CFM/SIDE THROW, FT.	469	327	625	437	782	546	937	656	1093	766	1250	875	1406	984
	2A 2B	CFM/SIDE THROW, FT.	562		750		937		1125		1312		1500		1687	
	2C 2D 2E 2F	CFM/SIDE THROW, FT.	787	337	1050	450	1313	562	1575	675	1838	787	2100	900	2363	1012
	1A 1B	CFM/SIDE THROW, FT.	1125		1500		1875		2250		2625		3000		3375	
36 x 18 4.5 SQ. FT.	RETURN FACTORS —SP=3.6 TP NC + 8	CFM NC	1350 16		1800 24		2250 30		2700 35		3150 39		3600 42		4050 45	
	4B 4C	CFM/SIDE THROW, FT.	506	169	675	225	844	281	1013	337	1181	394	1350	450	1519	506
	4E	CFM/SIDE THROW, FT.	339	339	452	452	565	565	678	678	791	791	904	904	1020	1020
	3A1	CFM/SIDE THROW, FT.	591	169	787	225	984	281	1181	337	1378	394	1575	450	1772	506
	3B	CFM/SIDE THROW, FT.	675	337	900	450	1125	562	1350	675	1575	787	1800	900	2025	1012
	2A 2B	CFM/SIDE THROW, FT.	675		900		1125		1350		1575		1800		2025	
	2C 2D 2E 2F	CFM/SIDE THROW, FT.	1010	337	1350	450	1688	562	2025	675	2363	787	2700	900	3038	1012
	1A 1B	CFM/SIDE THROW, FT.	1350		1800		2250		2700		3150		3600		4050	
24 x 21 3.5 SQ. FT.	RETURN FACTORS —SP=2.1 TP NC + 7	CFM NC	1050 15		1400 22		1750 28		2100 33		2450 37		2800 41		3150 44	
	4B 4C	CFM/SIDE THROW, FT.	295	230	394	306	493	382	590	460	690	535	788	612	887	688
	3A1	CFM/SIDE THROW, FT.	410	230	547	306	684	382	820	460	957	535	1094	612	1231	688
	3A2	CFM/SIDE THROW, FT.	375	300	500	400	625	500	750	600	875	700	1000	800	1125	900
	2A 2B	CFM/SIDE THROW, FT.	525		700		875		1050		1225		1400		1575	
	2C 2D 2E 2F	CFM/SIDE THROW, FT.	591	459	788	612	986	764	1180	920	1380	1070	1576	1224	1774	1376
	1A 1B	CFM/SIDE THROW, FT.	1050		1400		1750		2100		2450		2800		3150	

Notes:

1. Core style 4E is sized to give equal flow as near as possible in directions A and B.
2. For core styles 1A, 1B, 2A and 2B, the "A" direction is shown. Throw correction factor for "B" direction is: A x .82 = B.

For performance notes, see page D31.

Performance Data

Models 6500 and 6200 • Rectangular Neck

D

CEILING DIFFUSERS

NOMINAL NECK SIZE	BLOW PATTERNS	NECK VELOCITY TP	300 .033		400 .058		500 .090		600 .130		700 .177		800 .231		900 .293	
			A	B	A	B	A	B	A	B	A	B	A	B	A	B
30 x 21 4.375 SQ. FT.	RETURN FACTORS —SP=3.1 TP NC + 8	CFM NC	1310 16		1750 23		2185 29		2625 34		3060 38		3500 41		3935 44	
	4B 4C	CFM/SIDE THROW, FT.	425	230	569	306	710	382	852	460	995	535	1138	612	1279	688
	4E	CFM/SIDE THROW, FT.	360	295	480	394	600	492	720	591	840	690	960	788	1080	887
	3A1	CFM/SIDE THROW, FT.	540	230	722	306	901	382	1082	460	1262	535	1444	612	1623	688
	3A2	CFM/SIDE THROW, FT.	468	422	625	562	782	701	937	844	1093	983	1250	1125	1406	1264
	2A 2B	CFM/SIDE THROW, FT.	655		875		1092		1312		1530		1750		1968	
	2C 2E	CFM/SIDE THROW, FT.	853	457	1138	612	1421	764	1705	920	1990	1070	2276	1224	2559	1376
	1A 1B	CFM/SIDE THROW, FT.	1310		1750		2185		2625		3060		3500		3935	
36 x 21 5.25 SQ. FT.	RETURN FACTORS —SP=3.4 TP NC + 8	CFM NC	1575 16		2100 24		2625 30		3150 34		3675 38		4200 42		4725 45	
	4B 4C	CFM/SIDE THROW, FT.	558	230	744	306	930	382	1115	460	1306	535	1488	612	1674	688
	4E	CFM/SIDE THROW, FT.	427	360	568	480	710	600	852	720	945	840	1135	960	1280	1080
	3A1	CFM/SIDE THROW, FT.	672	230	897	306	1121	382	1345	460	1570	535	1794	612	2018	688
	3A2	CFM/SIDE THROW, FT.	675	450	900	600	1125	750	1350	900	1575	1050	1800	1200	2025	1350
	2A 2B	CFM/SIDE THROW, FT.	787		1050		1312		1575		1837		2100		2362	
	2C 2E	CFM/SIDE THROW, FT.	1115	460	1488	612	1861	764	2230	920	2605	1070	2976	1224	3349	1376
	1A 1B	CFM/SIDE THROW, FT.	1575		2100		2625		3150		3675		4200		4725	
30 x 24 5.0 SQ. FT.	RETURN FACTORS —SP=3.1 TP NC + 8	CFM NC	1500 17		2000 25		2500 30		3000 35		3500 39		4000 43		4500 46	
	4B 4C	CFM/SIDE THROW, FT.	450	300	600	400	750	500	900	600	1050	700	1200	800	1350	900
	4E	CFM/SIDE THROW, FT.	375	375	500	500	625	625	750	750	875	875	1000	1000	1125	1125
	3A1	CFM/SIDE THROW, FT.	600	300	800	400	1000	500	1200	600	1400	700	1600	800	1800	900
	3A2	CFM/SIDE THROW, FT.	515	470	687	625	859	782	1031	937	1203	1093	1375	1250	1548	1406
	2A 2B	CFM/SIDE THROW, FT.	750		1000		1250		1500		1750		2000		2250	
	2C 2E	CFM/SIDE THROW, FT.	900	600	1200	800	1500	1000	1800	1200	2100	1400	2400	1600	2700	1800
	1A 1B	CFM/SIDE THROW, FT.	1500		2000		2500		3000		3500		4000		4500	

Notes:

1. Core style 4E is sized to give equal flow as near as possible in directions A and B.
2. For core styles 1A, 1B, 2A and 2B, the "A" direction is shown. Throw correction factor for "B" direction is: A x .82 = B.

For performance notes, see page D31.

Performance Data

Models 6500 and 6200 • Rectangular Neck

NOMINAL NECK SIZE	BLOW PATTERNS	NECK VELOCITY TP	300 .033		400 .058		500 .090		600 .130		700 .177		800 .231		900 .293									
			CFM NC	1800 18	2400 25	3000 31	3600 36	4200 40	4800 43	5400 46														
36 x 24 6.0 SQ. FT.	RETURN FACTORS —SP=3.3 TP NC + 8	CFM NC	1800 18		2400 25		3000 31		3600 36		4200 40		4800 43		5400 46									
	4B 4C	CFM/SIDE THROW, FT.	600 300	800 400	1000 500	1200 600	1400 700	1600 800	1800 900	29-37-51	19-22-31	34-41-58	22-25-37	39-48-66	25-29-41	41-51-70	27-31-44	44-54-75	29-32-48	49-59-80	31-37-51	53-63-85	32-37-54	
	4E	CFM/SIDE THROW, FT.	450 450	600 600	750 750	900 900	1050 1050	1200 1200	1350 1350	25-31-42	24-31-42	29-37-51	29-37-51	32-41-58	32-41-58	35-44-61	35-44-61	37-48-66	37-48-66	41-51-71	41-51-71	42-54-75	42-54-75	
	3A1	CFM/SIDE THROW, FT.	750 300	1000 400	1250 500	1500 600	1750 700	2000 800	2250 900	31-37-54	19-22-31	37-42-61	22-25-37	41-49-70	25-29-41	44-54-75	27-31-44	48-58-80	29-32-48	51-61-85	31-37-51	54-65-90	32-37-54	
	3A2	CFM/SIDE THROW, FT.	676 562	900 750	1125 937	1350 1125	1575 1312	1800 1500	2025 1687	27-32-48	24-29-41	34-37-54	27-32-48	34-42-61	31-37-54	37-48-66	32-39-58	39-51-71	35-42-61	42-54-75	37-44-66	48-58-80	41-49-70	
	2A 2B	CFM/SIDE THROW, FT.	900 32-41-56	1200 37-48-65	1500 42-54-73	1800 48-58-78	2100 51-61-85	2400 54-66-90	2700 58-70-97															
	2C 2D 2E 2F	CFM/SIDE THROW, FT.	1200 600	1600 800	2000 1000	2400 1200	2800 1400	3200 1600	3600 1800	37-42-63	25-31-42	41-51-71	29-37-51	48-58-82	32-41-58	51-61-87	35-44-61	54-66-95	37-48-66	58-71-99	41-51-71	63-75-107	42-54-75	
	1A 1B	CFM/SIDE THROW, FT.	1800 41-51-70	2400 48-58-80	3000 54-66-90	3600 58-70-99	4200 61-75-105	4800 66-80-114	5400 70-85-122															
	36 x 30 7.5 SQ. FT.	RETURN FACTORS —SP=3.4 TP NC + 8	CFM NC	2250 19		3000 26		3750 32		4500 37		5250 41		6000 44		6750 47								
		4B 4C	CFM/SIDE THROW, FT.	657 468	875 625	1093 782	1313 937	1532 1093	1750 1250	1969 1406	29-37-51	20-25-34	34-41-58	24-29-39	39-48-66	27-32-44	41-51-70	29-37-49	44-54-75	31-37-53	49-59-80	32-41-56	53-63-85	37-42-59
3A1		CFM/SIDE THROW, FT.	890 468	1187 625	1484 782	1781 937	2078 1093	2375 1250	2672 1406	32-41-56	20-25-34	37-48-65	24-29-39	42-54-73	27-32-44	48-58-78	29-37-49	51-61-85	31-37-53	54-66-90	32-41-56	58-70-97	37-42-59	
3A2		CFM/SIDE THROW, FT.	787 675	1050 900	1312 1125	1575 1350	1837 1575	2100 1800	2362 2025	31-37-54	22-27-37	37-42-61	25-31-42	41-49-70	29-34-49	44-54-75	31-37-54	48-58-80	32-39-58	51-61-85	37-42-61	54-65-90	37-48-65	
2A 2B		CFM/SIDE THROW, FT.	1125 34-42-59	1500 39-49-68	1875 44-56-76	2250 49-59-83	2625 53-65-88	3000 56-68-97	3375 59-73-102															
2C 2D 2E 2F		CFM/SIDE THROW, FT.	1312 938	1750 1250	2188 1562	2625 1875	3063 2187	3500 2500	3938 2812	37-42-63	29-37-51	41-51-71	34-41-58	48-58-82	39-48-66	51-61-87	41-51-70	54-66-95	44-54-75	58-71-99	49-59-80	63-75-107	53-63-85	
1A 1B		CFM/SIDE THROW, FT.	2250 48-60-82	3000 56-68-94	3750 64-78-106	4500 68-82-116	5250 72-88-124	6000 78-94-134	6750 82-100-144															

Notes:

- Core style 4E is sized to give equal flow as near as possible in directions A and B.
- For core styles 1A, 1B, 2A and 2B, the "A" direction is shown. Throw correction factor for "B" direction is: $A \times .82 = B$.

- CFM** - cubic feet per minute
TP - total pressure - inches w.g.
T - throw in feet
NC - Noise Criteria (values) based on 10 dB room absorption, re 10^{-12} watts.
Neck Velocity – feet per minute

Performance Notes:

- Throw values are given for terminal velocities of 150, 100 and 50 fpm under isothermal conditions. Data applies to ceiling mounted units when the maximum coanda effect applies. When no ceiling is present (exposed duct), throws are reduced by approximately 25%.
- Sound levels in performance tables are for steel construction – **Model 6500**. Apply the following corrections for aluminum construction – **Model 6200**.
 $TP = \text{Listed value} \times 1.25$
 $NC = \text{Listed value} + 4$.

- Performance data as tabulated is for supply air conditions. Correction factors for return air application - see next page.
- Correction factors for adjustable models - see next page.
- Correction factors for round inlets - see next page.
- Data derived from tests conducted in accordance with ANSI/ASHRAE Standard 70 – 1991.

Performance Data Corrections

Model Series 6500 and 6200

CORRECTION FACTORS FOR RETURN INLET

If the unit is used as a return inlet, the performance data is obtained by applying the return corrections, as follows:

- Add the NC correction at the left side of the table to the NC value listed in the performance table.
- Multiply the listed SP factor at the left side of the table by the total pressure (TP) listed at the top of the table.

CORRECTION FACTORS FOR MODELS 6550 AND 6250 (ADJUSTABLE PATTERN CONTROLLERS) – TABLE 2

Refer to the performance data for the **Models 6500 and 6200**. Apply the corrections from Table 2 to the data for square, 4-way core styles, as follows:

- NC = listed + correction
- Total Pressure = listed x factor
- Horizontal Throw = listed
- Vertical Throw = listed x factor

Apply the throw factor to the 50 fpm terminal velocity throw only.

Example:

18" x 18", **Model 6500**, 1350 cfm, 20°F temperature difference heating, vertical projection, (Page D18).

- NC = 31 + 6 = 37
- TP = .13 x 2.1 = .273
- Throw = 36 x .9 = 32.4 feet @ 50 fpm terminal velocity.

CORRECTION FACTORS WITH SQUARE TO ROUND INLET ADAPTOR – TABLE 3

- Add the NC correction factor from Table 3 and the NC value listed in the performance tables.
- Multiply the correction factor from Table 3 by the listed total pressure in the performance tables.
- Multiply the correction factor from Table 3 by the listed throws in the performance tables.

Example:

12" x 12" unit with 10" round adaptor handling 500 cfm supply air. (Page D18).

- NC = 23 + 7 = 30
- Total Pressure = .09 x 1.65 = 0.149
- Throw = 21 x 1.15 = 24.15 feet @ 50 fpm terminal velocity.

Example:

12" x 12" unit handling 600 cfm of return air. (Page D18).

- Return NC = 28 + 4 = 32.
- Return negative SP = 1.3 x (- .13) = - .169.

TABLE 2 Correction Factors 6550/6250 Adjustable

NECK SIZE	NC (add)		TOTAL PRESSURE (multiply)		VERTICAL THROW (multiply)			
	H	V	H	V	COOLING, ΔT		HEATING, ΔT	
					20°F	0°F	20°F	40°F
6 x 6	2	6	1.2	1.5	1.3	1.1	0.8	0.6
9 x 9	2	6	1.4	2.1	1.5	1.2	0.9	0.6
12 x 12	2	6	1.4	2.1	1.6	1.3	1.0	0.6
15 x 15	2	6	1.4	2.1	1.7	1.3	1.0	0.6
18 x 18	2	6	1.4	2.1	1.7	1.3	0.9	0.6
21 x 21	2	6	1.4	2.1	1.7	1.3	0.8	0.5
24 x 24	2	6	1.6	2.2	1.5	1.1	0.7	0.3

TABLE 3 Correction Factors for SR Adaptors

SQUARE INLET	ROUND INLET	NC (add)	TP (multiply)	THROW (multiply)		
				150	100	50
6 x 6	5	7	1.65	1.10	1.10	1.15
9 x 9	6	17	3.50	1.15	1.15	1.20
9 x 9	8	4	1.40	1.10	1.10	1.10
12 x 12	8	17	3.50	1.15	1.15	1.20
12 x 12	10	7	1.65	1.10	1.10	1.15
15 x 15	10	17	3.50	1.15	1.15	1.20
15 x 15	12	9	1.90	1.10	1.10	1.15
15 x 15	14	3	1.25	1.05	1.05	1.10
18 x 18	12	17	3.50	1.15	1.15	1.20
18 x 18	14	10	2.00	1.10	1.10	1.15
18 x 18	16	5	1.45	1.10	1.10	1.10
21 x 21	14	17	3.70	1.15	1.15	1.20
21 x 21	16	11	2.25	1.10	1.10	1.15
21 x 21	18	6	1.60	1.10	1.10	1.10
21 x 21	20	3	1.20	1.05	1.05	1.10
24 x 24	16	17	3.50	1.15	1.15	1.20
24 x 24	18	12	2.35	1.10	1.10	1.15
24 x 24	20	7	1.65	1.10	1.10	1.15
24 x 24	22	4	1.33	1.05	1.05	1.10