

PERFORATED CURVED BLADE DIFFUSERS

- SUPPLY
- PREMIUM ARCHITECTURAL QUALITY
- 4-WAY ADJUSTABLE DISCHARGE PATTERN (STANDARD)
- 1, 2 OR 3-WAY DISCHARGE PATTERN (OPTIONAL)

Steel Face Model:

4330CB Flush Face

Aluminum Face Model:

4330CBA Flush Face

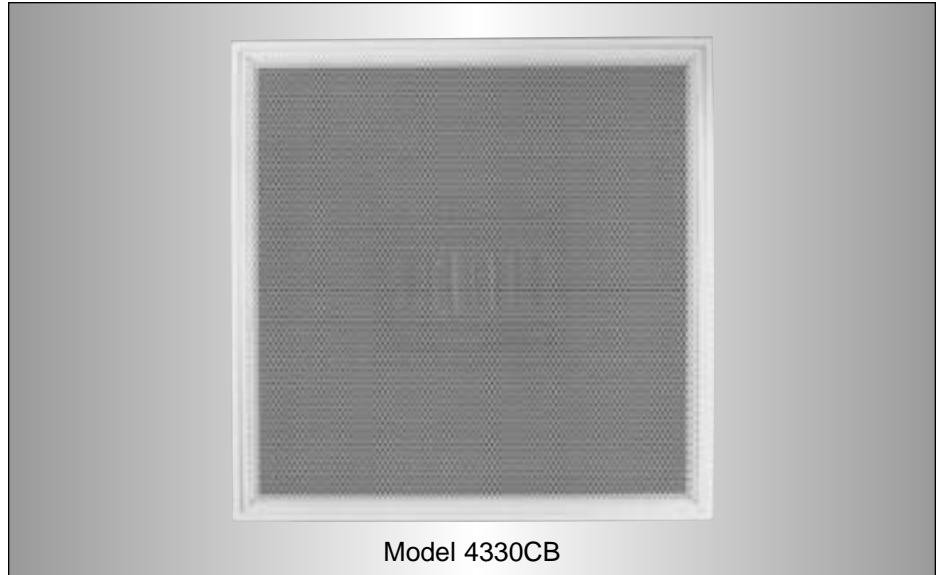

Model 4330CB

The **Nailor 4330CB Curved Blade Diffusers** provide the unobtrusive, smooth appearance preferred by many architects with superior features and performance characteristics. Designed to maximize throw, this model features individually adjustable, friction pivoted curved blade deflectors mounted directly under the neck. They project a tight, uniform horizontal blanket of air over a wide range of air volumes and provide excellent performance in variable air volume systems.

The **4330CB Diffuser** features an extruded aluminum frame with hairline mitered corners that encapsulates the perforated face providing a narrow, visible border within the T-Bar module. The deflector blades can be adjusted to control both the angle of discharge and hence throw from full horizontal to vertical in each direction and also damper the air volume. By closing off the deflectors in one or more directions, directional control can also be achieved. The **4330CB** is supplied with a 4-way adjustable discharge pattern as standard but is also available with a factory supplied 1, 2 or 3-way adjustable discharge pattern controller.

FEATURES:

- Round or square necks available.
- Hinged, removable face plate with quick-release spring latches.
- Discharge pattern can be adjusted from horizontal to vertical before or after installation.
- Discharge pattern is adjusted by dropping the perforated face and moving the curved blade deflectors.
- Inlet collar has 1 1/4" (32) depth for easy duct connection.
- Dropping the perforated face gives access to the optional damper.
- Perforated face with 3/16" (5) diameter holes on staggered 1/4" (6) centers, providing 51% free area.
- Return models (**4330R Series**) are available with the same face and frame construction as the supply models to match their appearance.

Material: Extruded aluminum border and frame, corrosion-resistant steel backpan. Corrosion-resistant steel or aluminum perforated face depending on model selection.

Finish: AW Appliance White baked enamel finish is standard. Other finishes are available.

Available Combinations of Ceiling Module vs. Neck Size

Ceiling Module CM		Nominal Duct Size D			
Imperial Modules	Metric Modules	Round Neck		Square Neck	
		Imperial Units (in.)	Metric Units (mm)	Imperial Units (in.)	Metric Units (mm)
12 x 12	300 x 300	6, 8	152, 203	6 x 6, 8 x 8	152 x 152, 203 x 203
24 x 12	600 x 300	6, 8	152, 203	6 x 6, 8 x 8, 18 x 6	152 x 152, 203 x 203, 457 x 152
16 x 16	400 x 400	6, 8, 10	152, 203, 254	6 x 6, 8 x 8	152 x 152, 203 x 203
20 x 20	500 x 500	6, 8, 10, 12, 14	152, 203, 254, 305, 356	6 x 6, 8 x 8, 10 x 10	152 x 152, 203 x 203, 254 x 254
24 x 24	600 x 600	6, 8, 10, 12, 14, 15, 16, 18	152, 203, 254, 305, 356, 381, 406, 457	6 x 6, 8 x 8, 10 x 10, 12 x 12, 14 x 14, 15 x 15, 16 x 16, 18 x 18	152 x 152, 203 x 203, 254 x 254, 305 x 305, 356 x 356, 381 x 381, 406 x 406, 457 x 457

Dimensional Data and Frame Types

Models 4330CB, 4330CBA • Supply • Flush Face

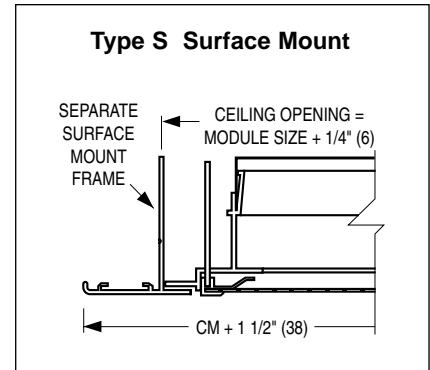
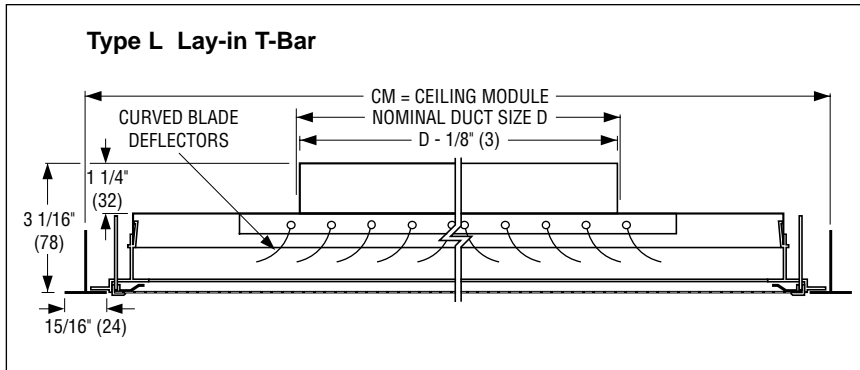

Model Series 4330CB • Adjusting Pattern Controllers

Removing Perforated Face

The **4330 Series** is supplied with a removable face plate that is retained in place with quick-release spring latches, located on the edge of the perforated face border.

1. Carefully insert a small screwdriver or similar object through a perforated hole in the edge of the face plate and pull the diffuser face down slightly. Grasp the face plate by hand and pull down to the extent of the spring latches on all sides.
2. The face plate will now hang by the extended spring latches. Compress the spring latches by hand and remove from the backpan.
3. When the latches are removed from three sides, the face will hinge down from the remaining latches for access to the pattern deflectors. The face can be completely removed by depressing the remaining latches.
4. To close; lift perforated face, depress the spring latches and snap in place.

The pattern controller in the neck of the diffuser features individually adjustable deflector blades which may be used to vary the discharge pattern from full horizontal to vertical. Each blade is friction pivoted using a tension wire which securely holds its position after adjustment.



Round or Square Neck • 4-way Pattern

Pattern Controller Options

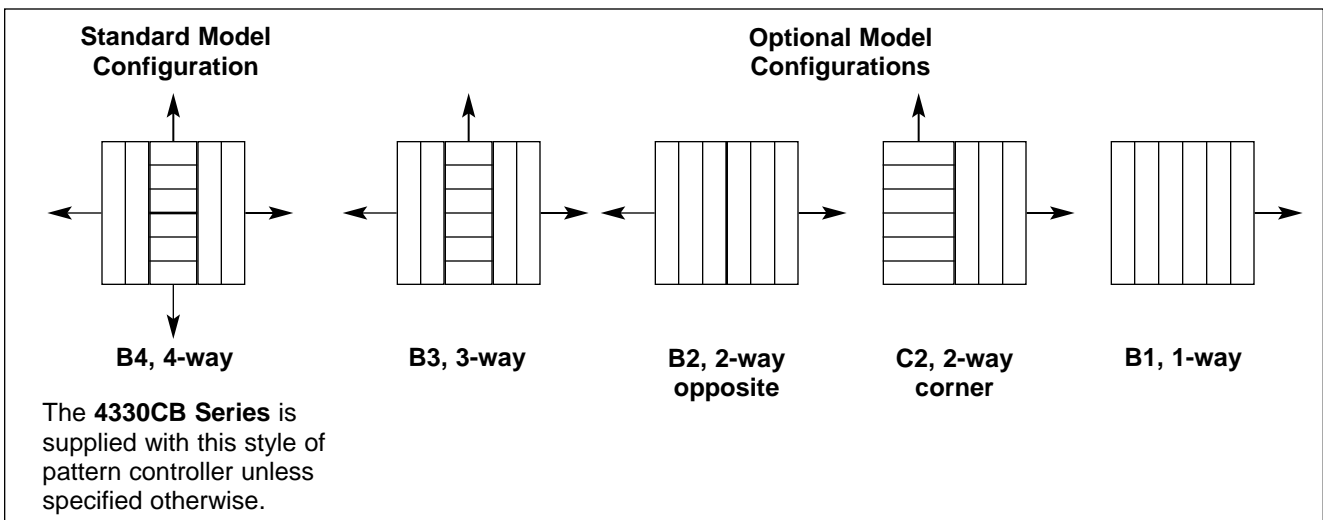

D
CEILING DIFFUSERS

HOW TO SPECIFY OR TO ORDER

(Show complete Model Number and Size, unless "Default" is desired).

Premium Perforated Curved Blade Supply Ceiling Diffusers – Model Series 4330CB

4330CB - 08 - 24 x 24 - L - AW - B4 - -

MODEL

- Steel Face 4330CB
- Aluminum Face 4330CBA

NECK SIZE (inches)

Round

06, 08, 10, 12, 14, 15, 16, 18

Square/Rectangular

6 x 6, 8 x 8, 10 x 10, 12 x 12,
14 x 14, 15 x 15, 16 x 16,
18 x 6, 18 x 18

CEILING MODULE

Imperial (inches) Metric (mm)

- 12 x 12 300 x 300
- 16 x 16 400 x 400
- 20 x 20 500 x 500
- 24 x 12 600 x 300
- 24 x 24 600 x 600
- 48 x 24 1200 x 600

FRAME TYPE

- Lay-in T-Bar L
- Surface Mount S

ACCESSORIES

- None (default) —
- External Foil Back Insulation EX
- Earthquake Tabs EQT

AIR BALANCING DEVICES

Round Neck

- Radial Sliding Blade Damper 4250
- Radial Opposed Blade Damper 4275
- Butterfly Damper 4675
- Equalizing Grid EGR
- Damper/Equalizing Grid DEGR

Square/Rectangular Neck

- Opposed Blade Damper OBD
- Equalizing Grid (long) EGL
- Equalizing Grid (short) EGS
- Damper/Equalizing Grid (long) DEGL
- Damper/Equalizing Grid (short) DEGS

BLOW PATTERN

- 4-Way (default) B4
- 3-Way B3
- 2-Way Opposite B2
- 2-Way Corner C2
- 1-Way B1

FINISH

- Appliance White (default) AW
- Special SP
- AW Face/Black Backpan BA

Notes:

1. Consult individual models as to limitations and availability of ceiling module and neck size combinations.
2. If more than one accessory is required, list in order.

SUGGESTED SPECIFICATION:

Furnish and install **Nailor Model** (select one) **4330CB** (corrosion-resistant steel face) or **4330CBA** (aluminum face) **Premium Architectural Perforated Supply Curved Blade Ceiling Diffusers** of the sizes and capacities as shown on the plans and air distribution schedules. The diffuser shall have a corrosion-resistant steel backpan with a round or square neck as specified, and an extruded aluminum border/frame that encapsulates the perforated face. The perforated face shall have 3/16" (5) dia. holes on 1/4" (6) staggered centers, providing 51% free area. Mounted on the neck of the diffuser shall be a factory installed curved blade pack with individually adjustable blades configured for a 4-way (standard) throw. (Optional) Factory installed 3, 2, or 1-way (select one) pattern to be supplied. The face shall include spring latches allowing easy access for cleaning and adjusting the deflectors (or optional damper). The finish shall be AW Appliance White baked enamel (optional finishes are available).

The manufacturer shall provide published performance data for the diffuser, which shall be tested in accordance with ANSI/ASHRAE Standard 70 – 1991.

Performance Data

Models 4330CB, 4330CBA • 12 x 12 (300 x 300) Module Size

Nominal Neck Size	Neck Velocity, FPM		300	400	500	600	700	800	900
	VP		.006	.010	.016	.023	.031	.040	.051
	TP		.030	.052	.082	.118	.162	.211	.267
6" Dia.	Flow Rate, CFM		60	80	95	115	135	155	175
	T	4-Way	1-2-4	2-3-6	2-4-7	3-5-7	3-5-8	4-6-9	5-6-9
		3-Way	2-3-6	2-4-8	3-5-11	4-6-12	5-7-13	5-8-14	6-10-15
		2-Way	2-4-8	3-5-11	4-6-13	5-8-15	6-9-16	7-11-18	8-12-20
		1-Way	3-4-9	4-6-12	5-8-16	6-9-18	7-11-20	8-12-22	9-14-23
NC		16	22	27	32	37	41	44	
8" Dia.	Flow Rate, CFM		105	140	175	210	245	280	315
	T	4-Way	2-3-6	2-4-8	3-5-9	4-6-10	4-7-11	4-8-12	5-9-12
		3-Way	2-3-7	3-4-9	3-5-11	4-7-12	5-8-13	6-9-14	7-10-14
		2-Way	3-4-9	4-6-13	5-8-15	6-9-17	7-11-18	8-13-20	9-14-21
		1-Way	3-5-11	5-7-15	6-9-18	7-11-21	8-13-22	10-15-24	11-17-25
NC		17	23	29	35	39	43	46	
6 x 6	Flow Rate, CFM		75	100	125	150	175	200	225
	T	4-Way	1-2-5	2-3-7	3-4-8	3-5-8	4-6-9	5-7-10	5-7-11
		3-Way	2-3-6	2-4-8	3-5-11	4-6-12	5-7-13	5-8-14	6-10-15
		2-Way	3-4-9	4-6-12	5-7-15	6-9-17	7-10-20	8-12-21	9-14-22
		1-Way	3-5-10	4-7-14	6-9-18	7-10-21	8-12-23	9-14-24	10-16-26
NC		16	22	27	32	36	40	43	
8 x 8	Flow Rate, CFM		135	175	220	265	310	355	400
	T	4-Way	2-3-6	3-4-9	3-5-10	4-6-11	5-8-12	6-9-13	6-10-14
		3-Way	2-3-7	3-5-10	4-6-12	5-7-13	6-9-14	7-10-15	7-11-16
		2-Way	3-5-11	4-7-14	6-9-17	7-11-20	8-13-21	9-14-23	11-16-24
		1-Way	4-6-12	5-8-17	7-10-21	8-12-23	9-14-25	11-17-27	12-20-28
NC		17	23	30	36	40	44	47	

Models 4330CB, 4330CBA • 24 x 12 (600 x 300) Module Size

Nominal Neck Size	Neck Velocity, FPM		300	400	500	600	700	800	900
	VP		.006	.010	.016	.023	.031	.040	.051
	TP		.030	.052	.082	.118	.162	.211	.267
6" Dia.	Flow Rate, CFM		60	80	95	115	135	155	175
	T	4-Way	1-2-4	2-3-6	2-4-7	3-5-7	3-5-8	4-6-9	5-6-9
		3-Way	2-3-6	2-4-8	3-5-11	4-6-12	5-7-13	5-8-14	6-10-15
		2-Way	2-4-8	3-5-11	4-6-13	5-8-15	6-9-16	7-11-18	8-12-20
		1-Way	3-4-9	4-6-12	5-8-16	6-9-18	7-11-20	8-12-22	9-14-23
NC		16	22	27	32	37	41	44	
8" Dia.	Flow Rate, CFM		105	140	175	210	245	280	315
	T	4-Way	2-3-6	2-4-8	3-5-9	4-6-10	4-7-11	4-8-12	5-9-12
		3-Way	2-3-7	3-4-9	3-5-11	4-7-12	5-8-13	6-9-14	7-10-14
		2-Way	3-4-9	4-6-13	5-8-15	6-9-17	7-11-18	8-13-20	9-14-21
		1-Way	3-5-11	5-7-15	6-9-18	7-11-21	8-13-22	10-15-24	11-17-25
NC		17	23	29	35	39	43	46	
6 x 6	Flow Rate, CFM		75	100	125	150	175	200	225
	T	4-Way	1-2-5	2-3-7	3-4-8	3-5-8	4-6-9	5-7-10	5-7-11
		3-Way	2-3-6	2-4-8	3-5-11	4-6-12	5-7-13	5-8-14	6-10-15
		2-Way	3-4-9	4-6-12	5-7-15	6-9-17	7-10-20	8-12-21	9-14-22
		1-Way	3-5-10	4-7-14	6-9-18	7-10-21	8-12-23	9-14-24	10-16-26
NC		16	22	27	32	36	40	43	
8 x 8	Flow Rate, CFM		135	175	220	265	310	355	400
	T	4-Way	2-3-6	3-4-9	3-5-10	4-6-11	5-8-12	6-9-13	6-10-14
		3-Way	2-3-7	3-5-10	4-6-12	5-7-13	6-9-14	7-10-15	7-11-16
		2-Way	3-5-11	4-7-14	6-9-17	7-11-20	8-13-21	9-14-23	11-16-24
		1-Way	4-6-12	5-8-17	7-10-21	8-12-23	9-14-25	11-17-27	12-20-28
NC		17	23	30	36	40	44	47	

For performance notes, see page D189.

Performance Data

Models 4330CB, 4330CBA • 24 x 24 (600 x 600) Module Size • Round Neck

Nominal Neck Size	Neck Velocity, FPM		300	400	500	600	700	800	900
	VP	TP	.006	.010	.016	.023	.031	.040	.051
6" Dia.	Flow Rate, CFM		60	80	95	115	135	155	175
	T	4-Way	1-2-4	2-3-6	2-3-7	3-4-7	3-5-8	4-6-9	4-6-9
3-Way		1-2-5	2-3-7	2-4-8	3-5-9	4-6-9	4-7-10	5-7-11	
2-Way		2-3-7	3-4-9	4-6-11	4-7-12	5-8-13	6-9-14	7-11-15	
1-Way		2-4-8	3-5-11	4-7-13	5-8-15	6-9-16	7-11-17	8-12-18	
NC		—	19	25	30	34	38	41	
8" Dia.	Flow Rate, CFM		105	140	175	210	245	280	315
	T	4-Way	2-3-6	2-4-8	3-5-9	4-6-10	4-7-11	4-8-12	5-9-12
3-Way		2-3-7	3-4-9	3-5-11	4-7-12	5-8-13	6-9-14	7-10-14	
2-Way		3-4-9	4-6-13	5-8-15	6-9-17	7-11-18	8-13-20	9-14-21	
1-Way		3-5-11	5-7-15	6-9-18	7-11-21	8-13-22	10-15-24	11-17-25	
NC		14	22	28	33	37	41	44	
10" Dia.	Flow Rate, CFM		165	215	270	325	380	435	490
	T	4-Way	2-3-7	3-5-10	4-6-12	5-7-13	5-8-14	6-10-15	7-11-16
3-Way		2-4-8	3-5-11	4-7-13	5-8-15	6-10-16	7-11-17	8-13-18	
2-Way		4-6-12	5-8-16	6-10-20	8-12-22	9-14-23	10-16-25	12-18-27	
1-Way		4-7-14	6-9-18	7-11-23	9-14-26	11-16-28	12-18-29	14-22-31	
NC		16	24	30	35	39	43	46	
12" Dia.	Flow Rate, CFM		235	315	390	470	550	625	705
	T	4-Way	3-4-9	4-6-12	5-7-14	6-9-15	7-10-17	8-12-18	9-13-20
3-Way		3-5-10	4-7-14	5-8-16	7-10-18	8-12-20	9-14-22	10-15-23	
2-Way		4-7-14	6-9-20	8-12-24	9-14-26	11-17-28	13-20-30	14-23-32	
1-Way		5-8-17	7-11-23	9-14-28	11-17-31	13-20-33	15-23-35	17-26-37	
NC		18	26	32	37	41	45	48	
14" Dia.	Flow Rate, CFM		320	425	535	640	750	855	960
	T	4-Way	3-5-10	4-7-14	5-8-16	7-10-18	8-12-21	9-14-22	10-16-23
3-Way		4-6-12	5-8-16	6-10-20	8-12-22	9-14-24	10-16-25	12-18-27	
2-Way		5-8-17	7-11-24	9-14-28	11-17-30	13-21-33	15-24-35	17-26-37	
1-Way		6-9-20	8-13-27	11-16-33	13-20-36	15-24-38	17-27-41	20-30-43	
NC		21	29	35	39	44	48	51	
15" Dia.	Flow Rate, CFM		370	490	615	740	860	985	1100
	T	4-Way	3-6-10	4-2-14	5-8-17	8-10-19	8-13-21	10-14-23	10-16-24
3-Way		4-6-12	6-8-17	6-11-21	8-13-22	10-14-25	11-16-26	13-18-28	
2-Way		4-8-17	7-12-25	9-15-30	11-18-31	13-22-34	16-25-35	17-27-38	
1-Way		6-9-20	8-14-28	12-17-34	14-21-37	16-24-39	18-27-42	17-31-43	
NC		22	30	36	40	45	49	52	
16" Dia.	Flow Rate, CFM		420	560	700	835	975	1115	1255
	T	4-Way	4-6-12	5-8-16	6-10-20	8-12-22	9-14-23	10-16-25	12-18-26
3-Way		4-7-14	6-9-18	7-11-23	9-14-25	10-16-27	12-18-29	14-22-30	
2-Way		6-9-20	8-13-27	10-16-32	13-20-35	15-24-37	17-27-40	20-30-42	
1-Way		7-11-23	10-15-31	12-18-37	15-23-41	17-27-44	21-31-47	23-35-50	
NC		23	31	37	41	46	50	53	
18" Dia.	Flow Rate, CFM		530	705	885	1060	1235	1415	1590
	T	4-Way	4-7-14	5-9-18	7-10-20	9-13-24	10-16-26	10-19-28	13-21-29
3-Way		4-7-17	6-10-21	8-12-24	10-15-28	11-20-30	13-22-32	17-24-34	
2-Way		7-10-23	10-14-29	11-17-34	15-22-36	18-28-43	20-30-44	24-34-50	
1-Way		8-12-26	11-17-33	14-21-40	18-25-45	21-32-50	23-38-53	29-40-56	
NC		25	33	39	43	48	52	55	

For performance notes, see page D189.

Performance Data

Models 4330CB, 4330CBA • 24 x 24 (600 x 600) Module Size • Square Neck

Nominal Neck Size	Neck Velocity, FPM		300	400	500	600	700	800	900
	VP		.006	.010	.016	.023	.031	.040	.051
	TP		.028	.050	.079	.113	.155	.202	.256
6 x 6	Flow Rate, CFM		75	100	125	150	175	200	225
	T	4-Way	1-2-5	2-3-7	3-4-8	3-5-8	4-6-9	5-7-10	5-7-11
		3-Way	2-3-6	2-4-8	3-5-11	4-6-12	5-7-13	5-8-14	6-10-15
		2-Way	3-4-9	4-6-12	5-7-15	6-9-17	7-10-20	8-12-21	9-14-22
		1-Way	3-5-10	4-7-14	6-9-18	7-10-21	8-12-23	9-14-24	10-16-26
NC		—	20	26	31	35	39	42	
8 x 8	Flow Rate, CFM		135	175	220	265	310	355	400
	T	4-Way	2-3-6	3-4-9	3-5-10	4-6-11	5-8-12	6-9-13	6-10-14
		3-Way	2-3-7	3-5-10	4-6-12	5-7-13	6-9-14	7-10-15	7-11-16
		2-Way	3-5-11	4-7-14	6-9-17	7-11-20	8-13-21	9-14-23	11-16-24
		1-Way	4-6-12	5-8-17	7-10-21	8-12-23	9-14-25	11-17-27	12-20-28
NC		15	23	29	34	38	42	45	
10 x 10	Flow Rate, CFM		210	275	345	415	485	555	625
	T	4-Way	2-4-8	3-5-11	4-7-13	5-8-14	6-10-16	7-11-17	8-12-18
		3-Way	3-4-9	4-6-13	5-8-15	6-9-17	7-11-18	8-13-20	9-14-22
		2-Way	4-6-13	6-9-18	7-11-22	9-13-25	10-16-26	12-18-28	13-21-30
		1-Way	5-8-16	7-10-22	8-13-26	10-16-29	12-18-31	14-22-33	16-25-35
NC		17	25	31	36	40	44	47	
12 x 12	Flow Rate, CFM		300	400	500	600	700	800	900
	T	4-Way	3-5-10	4-6-13	5-8-16	6-10-17	8-12-20	9-13-21	10-15-22
		3-Way	3-5-11	5-7-15	6-9-18	7-11-21	9-13-23	10-15-24	11-17-26
		2-Way	5-8-16	7-11-23	9-13-27	11-16-29	13-20-32	14-23-34	16-25-36
		1-Way	6-9-20	8-12-26	10-16-31	12-20-34	14-23-37	17-26-40	22-31-44
NC		19	25	33	38	42	46	49	
14 x 14	Flow Rate, CFM		410	545	680	815	955	1090	1360
	T	4-Way	1-1-6	1-3-8	2-4-11	3-6-13	4-7-15	5-8-17	7-11-22
		3-Way	1-3-10	2-6-14	4-9-18	6-10-21	8-12-26	9-14-29	11-18-37
		2-Way	2-5-14	4-9-19	7-12-24	9-14-30	11-17-35	13-19-40	16-24-47
		1-Way	3-8-17	6-11-23	9-14-30	11-17-36	13-20-42	15-23-48	19-30-54
NC		22	30	36	40	45	49	52	
15 x 15	Flow Rate, CFM		470	625	780	935	1095	1250	1405
	T	4-Way	4-6-12	5-8-17	7-10-21	8-12-23	10-15-25	11-17-26	12-20-28
		3-Way	4-7-14	6-9-20	8-12-24	9-14-26	11-17-28	13-20-30	14-23-32
		2-Way	6-10-21	9-13-28	11-17-33	13-21-37	16-25-40	18-28-42	21-32-45
		1-Way	8-12-25	10-16-33	13-21-39	16-25-43	18-29-46	22-33-49	25-37-53
NC		23	31	37	41	46	50	53	
16 x 16	Flow Rate, CFM		530	710	890	1065	1245	1420	1600
	T	4-Way	4-7-14	5-9-18	7-10-20	9-13-24	10-16-26	10-19-28	13-21-29
		3-Way	4-7-17	6-10-21	8-12-24	10-15-28	11-20-30	13-22-32	17-24-34
		2-Way	7-10-23	10-14-29	11-17-34	15-22-36	18-28-43	20-30-44	24-34-50
		1-Way	8-12-26	11-17-33	14-21-40	18-25-45	21-32-50	23-38-53	29-40-56
NC		24	32	38	42	47	51	54	
18 x 18	Flow Rate, CFM		675	900	1125	1350	1575	1800	2025
	T	4-Way	5-7-15	6-10-21	8-12-25	10-15-27	12-18-30	13-21-32	15-24-33
		3-Way	5-8-17	7-11-24	9-14-29	11-17-32	13-22-34	15-24-36	17-27-39
		2-Way	8-12-26	11-16-34	13-21-40	16-26-44	20-30-47	23-34-50	26-38-54
		1-Way	9-14-29	12-20-39	16-25-47	20-29-52	23-34-56	26-39-60	29-44-64
NC		26	34	40	44	49	53	56	

D
CEILING DIFFUSERS

- CFM** - cubic feet per minute
- FPM** - feet per minute velocity
- TP** - total pressure - inches w.g.
- VP** - velocity pressure - inches w.g.
- T** - throw in feet
- NC** - Noise Criteria (values) based on 10 dB room absorption, re 10⁻¹² watts.

- Performance Notes:**
1. Throws are given at 150, 100 and 50 fpm terminal velocities under isothermal conditions.
 2. Data derived from tests conducted in accordance with ANSI/ASHRAE Standard 70 – 1991.

Balancing:
It is recommended that a commercially available 'Flow Hood' is used for field balancing. The airflow meter directly reads average flow rate with great accuracy at all volumes. It is a much faster and more accurate alternative to time consuming multiple velocity readings, eliminating the use of Ak factors and the calculations required to convert the average velocity into airflow.