

## PERFORATED MODULAR CORE DIFFUSERS

- SUPPLY
- INTEGRAL ROUND NECK
- 1, 2, 3 OR 4-WAY ADJUSTABLE DISCHARGE PATTERN

### Steel Models:

- 4320MR Flush Face
- 4325MR Drop Face

### Aluminum Face Models:

- 4320MRA Flush Face
- 4325MRA Drop Face

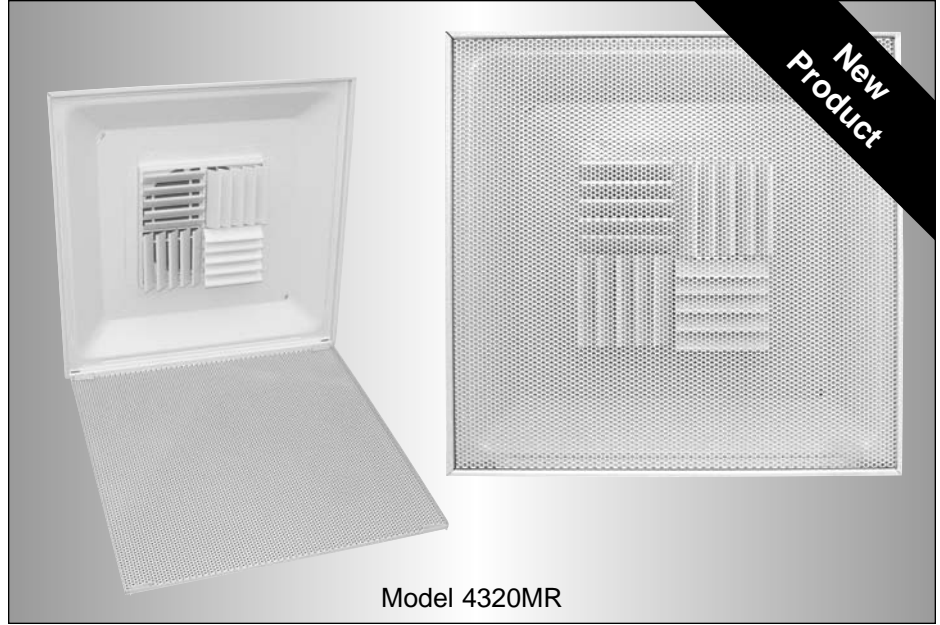

D

CEILING DIFFUSERS

The **Nailor 4320MR Perforated Modular Core Diffusers** provide the unobtrusive, smooth appearance preferred by many architects and combines this with the flexible features of a high performance modular core design. The low profile backpan features an integral round neck which eliminates the need for adapters. Four individual spring-loaded adjustable modular pattern controllers are mounted inside the backpan. This positions the leading edge of the pattern controllers near the perforated face and flush with ceiling for optimum performance. The engineered design maintains a tight, uniform horizontal throw pattern from maximum to minimum cataloged air volumes and therefore provides excellent performance in VAV systems.

Discharge pattern can adjust to 1, 2, 3 or 4-way horizontal, before or after installation.

Discharge pattern is adjusted by dropping the perforated face and rotating the pattern deflectors. Diffusers are shipped from the factory with a 4-way discharge pattern.

The **4325MR** features a dropped (extended) face panel that is designed to compliment tegular tile ceiling systems. The face panel is suspended flush with the ceiling line, providing both an aesthetically pleasing appearance and ensuring optimal performance is maintained.

### FEATURES:

- Designed for suspended ceiling systems.
- Round neck is standard.
- Hinged, removable face plate with quick-release spring latches.
- Discharge pattern can be adjusted to a 1, 2, 3 or 4-way horizontal pattern before or after installation.
- Discharge pattern is adjusted by dropping the perforated face and rotating the modular sections.
- Inlet collar has approximately 1 1/4" (32) depth for easy duct connection.
- Perforated face with 3/16" (5) diameter holes on staggered 1/4" (6) centers, providing 51% free area.
- Dropping the perforated face and removing a modular core module gives access to the optional balancing damper.
- Return models (**4360 Series**) have the same face and frame construction as the supply models to match the appearance.

**Material:** Corrosion-resistant steel backpan and modular core. Corrosion-resistant steel or aluminum perforated face depending on model selection.

**Finish:** AW Appliance White baked enamel finish is standard. Other finishes are available.

### Available Combinations of Ceiling Module vs. Neck Size

Ceiling Module CM		Nominal Duct Size D	
Imperial Modules	Metric Modules	Round Neck	
		Imperial Units (in.)	Metric Units (mm)
12 x 12	300 x 300	6, 8 dia.	152, 203 dia.
24 x 24	600 x 600	6, 8, 10, 12, 14, 15, 16 dia.	152, 203, 254, 305, 356, 381, 406 dia.

## Dimensional Data and Frame Types

Models 4320MR, 4320MRA • Flush Face • Round Neck

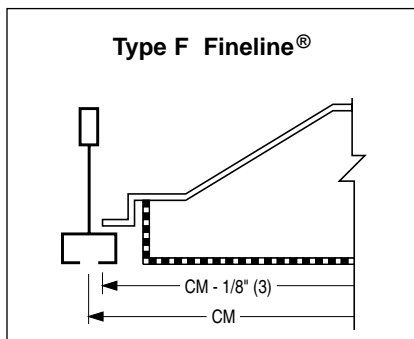
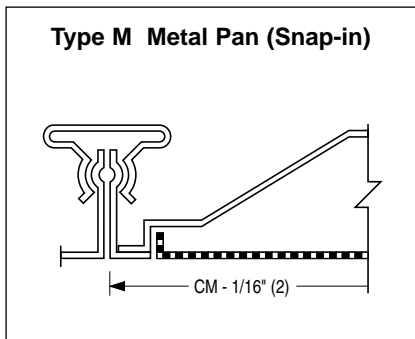
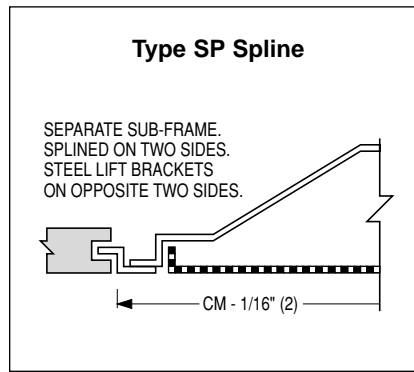
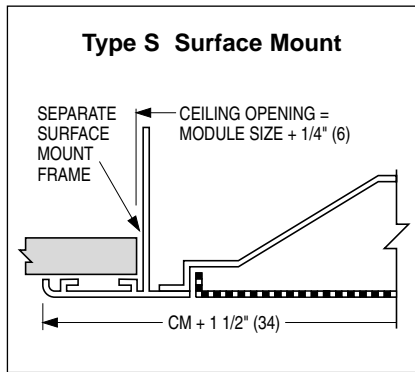
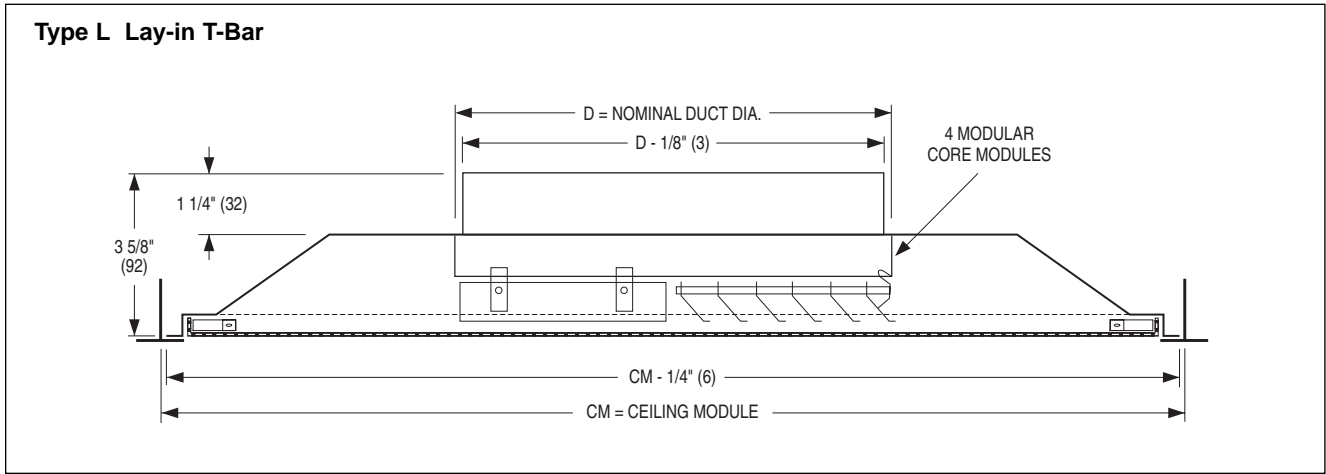

## Modular Core Adjustments

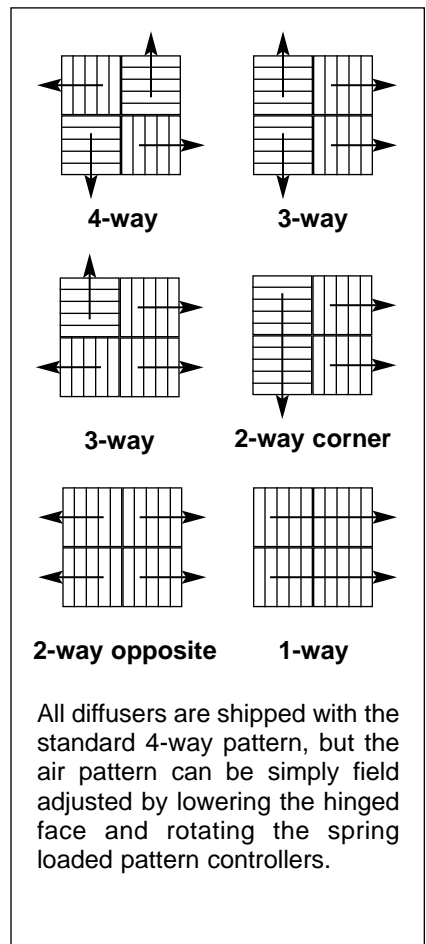

Models 4325MR, 4325MRA • Drop Face • Round Neck

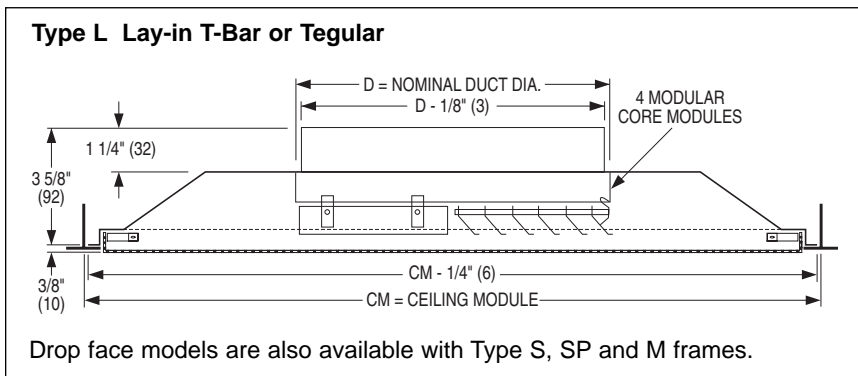

## HOW TO SPECIFY OR TO ORDER

(Show complete Model Number and Size, unless "Default" is desired).

### Perforated Modular Core Round Neck Supply Ceiling Diffusers – Model Series 4320MR

**4320MR - 08 - 24 x 24 - L - AW - -**

#### MODEL

- Steel	Flush Face	4320MR
	Drop Face	4325MR
- Aluminum Face	Flush Face	4320MRA
	Drop Face	4325MRA

#### NECK SIZE

06, 08, 10, 12, 14, 15, 16 dia.  
(152, 203, 254, 305, 356, 381, 406 dia.)

#### CEILING MODULE

##### Imperial (inches) Metric (mm)

- 24 x 24 (default)	600 x 600
- 12 x 12	300 x 300

#### ACCESSORIES

- None (default)	—
- External Foil Back Insulation	EX
- Earthquake Tabs	EQT

#### AIR BALANCING DEVICES

- Radial Sliding Blade Damper	4250
- Radial Opposed Blade Damper	4275
- Butterfly Damper	4675
- Equalizing Grid	EGR
- Damper/Equalizing Grid	DEGR

#### FINISH

- Appliance White (default)	AW
- Special Custom Color	SP
- AW Face/Black Backpan	BA

#### FRAME TYPE

- T-Bar Lay-in	L
- Surface Mount	S
- Spline	SP
- Metal Pan Snap-in	M
- Finline®	F

#### Notes:

1. Consult individual models as to limitations and availability of ceiling module and neck size combinations.
2. If more than one accessory is required, list in order.

#### SUGGESTED SPECIFICATION:

##### Models 4320MR, 4325MR – Steel

Furnish and install **Nailor Model** (select one) **4320MR Flush Face** or **4325MR Drop Face, Perforated Modular Core Supply Ceiling Diffusers** of the sizes and capacities as shown on the plans and air distribution schedules. The diffuser shall have a heavy gauge, stamped, corrosion-resistant steel, low profile backpan with an integral round neck. A corrosion-resistant steel perforated face shall have 3/16" (5) dia. holes on 1/4" (6) staggered centers, providing 51% free area. Mounted below the neck of the diffuser shall be four square modular pattern deflectors, factory installed in a 4-way pattern, that are easily field rotated to provide throws in 1, 2, or 3-way patterns. The face shall be removable, hinged and include quick-release spring latches allowing easy access for cleaning and rotating the deflectors (or optional damper). The finish shall be AW Appliance White baked enamel (optional finishes are available).

The manufacturer shall provide published performance data for the diffuser, which shall be tested in accordance with ANSI/ASHRAE Standard 70 – 1991.

##### Models 4320MRA, 4325MRA – Aluminum Face

Furnish and install **Nailor Model** (select one) **4320MRA Flush Face** or **4325MRA Drop Face, Perforated Modular Core Supply Ceiling Diffusers** of the sizes and capacities as shown on the plans and air distribution schedules. The diffuser shall have a heavy gauge, stamped, corrosion-resistant steel, low profile backpan with an integral round neck. An aluminum perforated face shall have 3/16" (5) dia. holes on 1/4" (6) staggered centers, providing 51% free area. Mounted below the neck of the diffuser shall be four square modular pattern deflectors, factory installed in a 4-way pattern, that are easily field rotated to provide throws in 1, 2, or 3-way patterns. The face shall be removable, hinged and include quick-release spring latches allowing easy access for cleaning and rotating the deflectors (or optional damper). The finish shall be AW Appliance White baked enamel (optional finishes are available).

The manufacturer shall provide published performance data for the diffuser, which shall be tested in accordance with ANSI/ASHRAE Standard 70 – 1991.

## Performance Data

### Models 4320MR, 4320MRA • 12 x 12 (300 x 300) Module Size • Round Neck

Nominal Neck Size	Neck Velocity, FPM	300	400	500	600	700	800	1000	
	VP	.006	.010	.016	.023	.031	.040	.063	
6" Dia.	TP	.016	.031	.041	.065	.092	.124	.163	
	Flow Rate, CFM	60	80	100	115	135	155	195	
	T	4-Way	1-1-1	1-1-2	1-1-3	1-1-4	1-2-5	1-2-5	2-3-7
		3-Way	1-1-3	1-2-5	2-3-6	2-3-7	3-4-8	3-5-9	4-6-12
		2-Way	1-1-3	1-1-4	1-2-5	1-3-6	1-4-8	2-4-9	3-5-11
		1-Way	1-1-4	1-1-7	1-2-8	1-4-9	2-5-10	3-7-13	5-8-15
NC	—	—	18	23	29	33	38		
8" Dia.	TP	.015	.027	.043	.062	.084	.110	.171	
	Flow Rate, CFM	105	140	175	210	245	280	350	
	T	4-Way	1-1-2	1-1-4	1-2-5	1-2-6	1-3-7	2-4-8	3-5-10
		3-Way	1-2-5	1-3-7	2-4-8	3-5-9	4-6-11	4-7-13	5-9-16
		2-Way	1-1-4	1-2-6	1-3-9	2-4-9	3-5-11	3-6-13	5-8-16
		1-Way	1-2-7	1-4-9	2-6-12	4-7-14	5-9-17	6-10-19	8-13-21
NC	—	15	24	27	33	37	42		

For performance notes, see page D172.

**D**

**CEILING DIFFUSERS**

## Performance Data

### Models 4320MR, 4320MRA • 24 x 24 (600 x 600) Module Size • Round Neck

Nominal Neck Size	Neck Velocity, FPM	300	400	500	600	700	800	1000	
	VP	.006	.010	.016	.023	.031	.040	.063	
6" Dia.	TP	.016	.031	.041	.065	.092	.124	.163	
	Flow Rate, CFM	60	80	100	115	135	155	195	
	T	4-Way	1-1-1	1-1-2	1-1-3	1-1-4	1-2-5	1-2-5	2-3-7
		3-Way	1-1-3	1-2-5	2-3-6	2-3-7	3-4-9	3-5-10	4-6-13
		2-Way	1-1-3	1-1-4	1-2-5	1-3-7	1-4-8	2-4-9	3-5-11
1-Way		1-1-4	1-1-7	1-2-8	1-4-10	2-5-12	3-7-14	5-8-16	
NC	—	—	16	21	26	30	37		
8" Dia.	TP	.015	.027	.043	.062	.084	.110	.171	
	Flow Rate, CFM	105	140	175	210	245	280	350	
	T	4-Way	1-1-2	1-1-4	1-2-5	1-2-6	1-3-7	2-4-8	3-5-10
		3-Way	1-2-5	1-3-7	2-4-8	3-5-10	4-6-12	4-7-14	5-9-17
		2-Way	1-1-4	1-2-6	1-3-8	2-4-9	3-5-11	3-6-13	5-8-16
1-Way		1-2-7	1-4-10	2-6-13	4-7-15	5-9-17	6-10-19	8-13-21	
NC	—	13	20	25	30	34	41		
10" Dia.	TP	.019	.033	.052	.075	.102	.133	.208	
	Flow Rate, CFM	165	220	270	325	380	435	545	
	T	4-Way	1-1-4	1-1-6	1-3-7	1-4-9	2-5-10	3-6-12	5-7-13
		3-Way	1-3-6	2-4-9	3-5-11	4-6-13	5-7-15	6-9-17	7-11-19
		2-Way	1-1-6	1-3-8	2-5-10	3-6-13	4-7-15	5-8-17	7-10-19
1-Way		1-4-10	3-7-14	5-9-18	7-10-20	8-12-21	9-14-23	12-18-26	
NC	—	16	23	28	33	37	44		
12" Dia.	TP	.023	.040	.063	.091	.124	.162	.253	
	Flow Rate, CFM	235	315	390	470	550	630	785	
	T	4-Way	1-1-6	1-2-8	2-4-10	2-6-12	3-7-13	5-8-14	6-10-16
		3-Way	1-3-8	3-5-11	4-6-13	5-8-15	6-9-17	7-11-18	9-13-20
		2-Way	1-2-8	2-5-11	3-6-13	5-8-16	6-9-17	7-11-18	9-13-20
1-Way		3-7-14	5-9-19	8-12-21	9-14-23	11-17-25	13-19-27	16-21-30	
NC	—	19	26	31	36	40	47		
14" Dia.	TP	.027	.049	.076	.110	.149	.195	.304	
	Flow Rate, CFM	320	425	535	640	750	855	1070	
	T	4-Way	1-2-8	1-4-11	2-6-13	4-8-14	5-9-15	7-11-16	9-13-18
		3-Way	2-4-10	3-6-12	5-8-13	6-10-15	7-11-16	8-12-17	11-13-19
		2-Way	1-4-10	3-6-13	5-8-15	6-10-16	7-11-18	9-13-19	11-15-21
1-Way		4-9-19	8-13-22	10-16-24	13-19-27	15-20-29	17-22-31	20-24-35	
NC	14	23	30	35	40	44	51		
16" Dia.	TP	.033	.059	.092	.132	.180	.235	.368	
	Flow Rate, CFM	420	560	700	835	975	1115	1295	
	T	4-Way	1-3-10	2-5-13	3-8-15	5-10-16	7-12-17	9-13-19	12-15-21
		3-Way	3-5-9	5-7-10	6-8-11	7-9-12	8-9-13	8-10-14	9-11-16
		2-Way	2-5-11	4-8-13	6-10-14	8-11-16	9-12-17	10-13-18	12-14-20
1-Way		7-12-21	11-17-24	14-19-27	17-21-30	18-23-32	20-24-35	22-27-39	
NC	15	24	31	36	41	45	52		

**D**  
**CEILING DIFFUSERS**

- CFM - cubic feet per minute
- FPM - feet per minute velocity
- TP - total pressure - inches w.g.
- VP - velocity pressure - inches w.g.
- T - throw in feet
- NC - Noise Criteria (values) based on 10 dB room absorption, re 10<sup>-12</sup> watts.

#### Performance Notes:

1. Throws are given at 150, 100 and 50 fpm terminal velocities under isothermal conditions.
2. Data derived from tests conducted in accordance with ANSI/ASHRAE Standard 70 – 1991.

#### Balancing:

It is recommended that a commercially available 'Flow Hood' is used for field balancing. The airflow meter directly reads average flow rate with great accuracy at all volumes. It is a much faster and more accurate alternative to time consuming multiple velocity readings, eliminating the use of Ak factors and the calculations required to convert the average velocity into airflow.