

PERFORATED CEILING DIFFUSERS

- SUPPLY
- FIXED 4-WAY DISCHARGE PATTERN

Steel Models:

- 4320F Flush Face
- 4325F Drop Face

Aluminum Face Models:

- 4320FA Flush Face
- 4325FA Drop Face

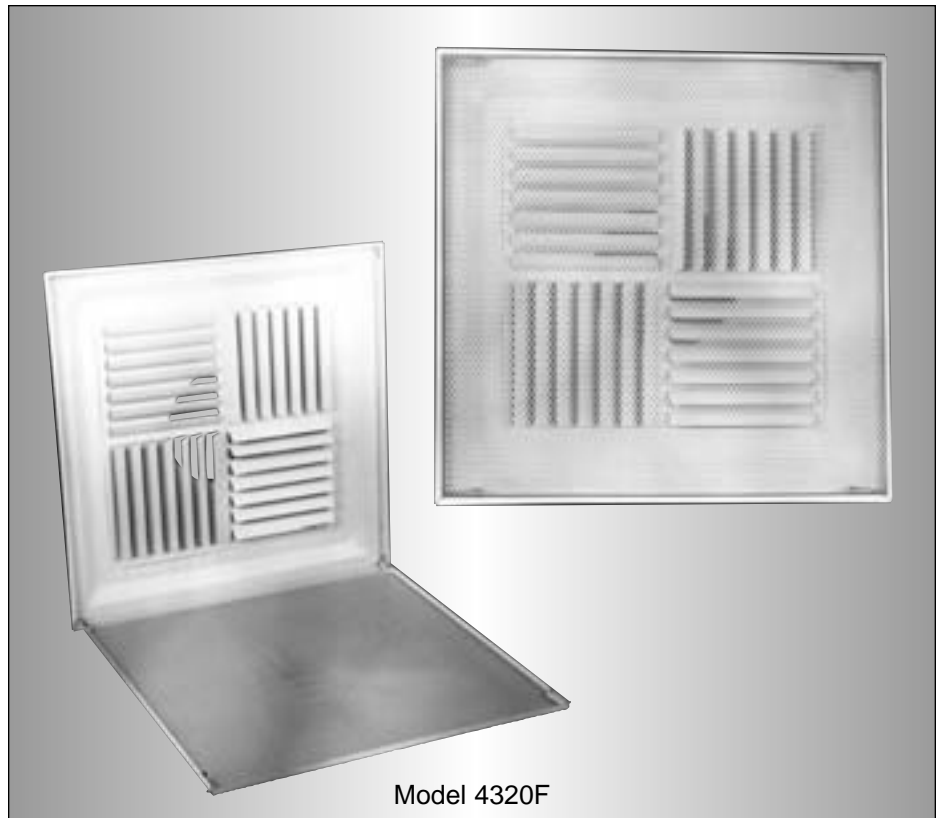

Model 4320F

The **Nailor 4320F Series Perforated Diffusers** combine smooth, unobtrusive architectural appearance with the superior performance characteristics required by engineers. Designed to maximize throw, these models feature a single heavy gauge stamped pattern controller that is mounted directly under the neck. The formed louver air pattern controller has fixed curved vanes that optimize airflow projection and provide a superior horizontal air pattern with a strong ceiling coanda effect. An excellent choice for variable air volume systems.

A main benefit of the **4320F Series** design is that the fixed pattern controller cannot be inadvertently adjusted, disturbed or tampered with. You can be assured that once installed, be it long or short term, the air pattern projection and performance will remain constant.

The **4325F** features a drop (extended) face panel that is available to compliment tegular tile ceiling systems. This ensures the panel remains flush with the ceiling line.

FEATURES:

- Round or square necks available.
- Hinged, removable face plate with quick-release spring latches.
- Rugged fixed 4-way air pattern controller ensures performance is always optimized.
- Inlet collar has 1 1/4" (32) depth for easy duct connection.
- Dropping the perforated face gives access to the optional damper.
- Perforated face with 3/16" (5) diameter holes on staggered 1/4" (6) centers, providing 51% free area.
- Return models (**4360 Series**) have the same face and frame construction as the supply models to match their appearance.

Material: Corrosion-resistant steel backpan. Corrosion-resistant steel or aluminum perforated face depending on model selection.

Finish: AW Appliance White baked enamel finish is standard. Other finishes are available.

Available Combinations of Ceiling Module vs. Neck Size

Ceiling Module CM		Nominal Duct Size D			
Imperial Modules	Metric Modules	Round Neck		Square Neck	
		Imperial Units (in.)	Metric Units (mm)	Imperial Units (in.)	Metric Units (mm)
24 x 24	600 x 600	6, 8, 10,	152, 203, 254,	6 x 6, 8 x 8, 10 x 10	152 x 152, 203 x 203, 254 x 254
		12, 14, 15,	305, 356, 381,	12 x 12, 14 x 14, 15 x 15	305 x 305, 356 x 356, 381 x 381
		16 dia.	406 dia.	16 x 16	406 x 406

Dimensional Data and Frame Types

Models 4320F, 4320FA • Supply • Flush Face

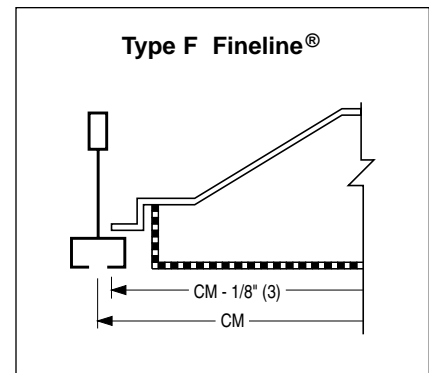
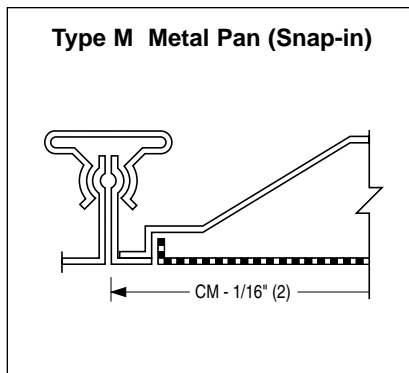
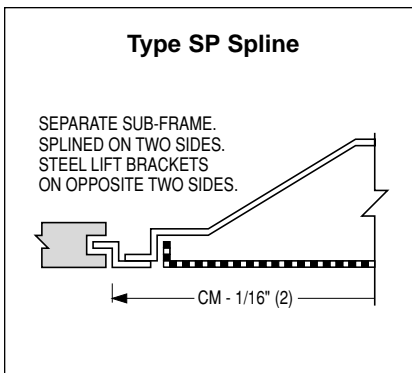
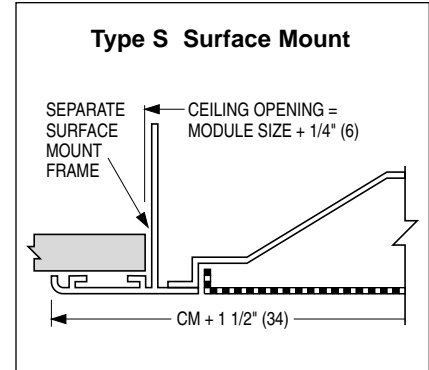
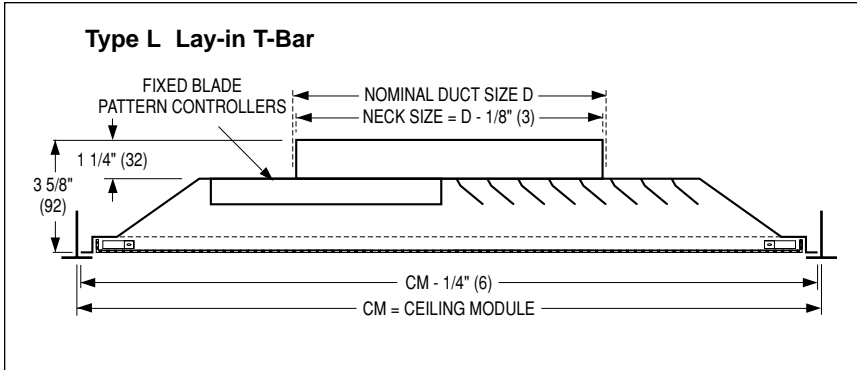

Models 4325F, 4325FA • Supply • Drop Face

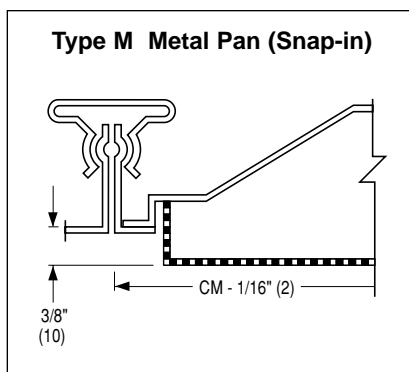
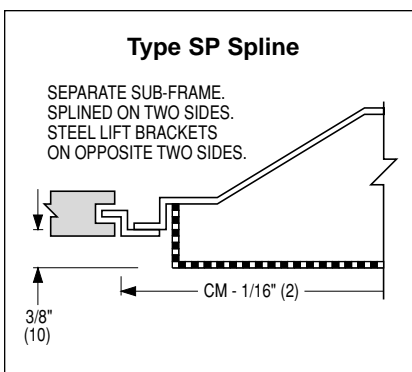
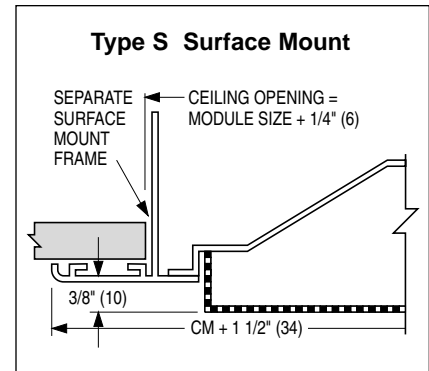
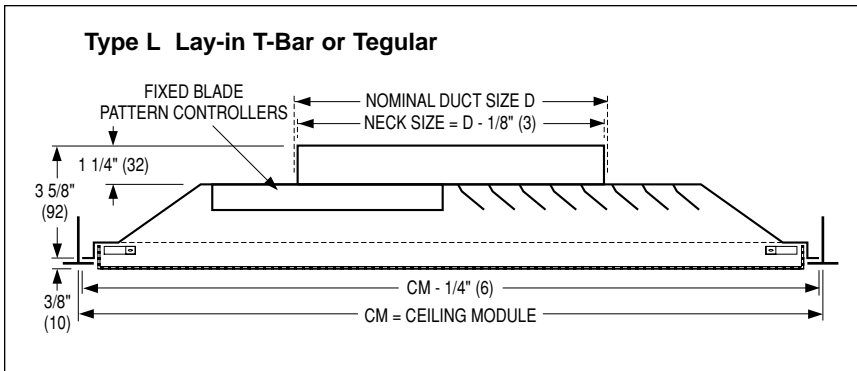

HOW TO SPECIFY OR TO ORDER

(Show complete Model Number and Size, unless "Default" is desired).

Perforated Fixed Pattern Ceiling Diffusers – Model Series 4320F

4320F - 08 - 24 x 24 - L - AW - -

MODEL

- Steel	Flush Face	4320F
	Drop Face	4325F
- Aluminum Face	Flush Face	4320FA
	Drop Face	4325FA

NECK SIZE (inches)

Round

06, 08, 10, 12, 14, 15, 16

Square

6 x 6, 8 x 8, 10 x 10, 12 x 12,
14 x 14, 15 x 15, 16 x 16

CEILING MODULE

Imperial (inches) Metric (mm)

- 24 x 24 600 x 600

ACCESSORIES

- None (default)	—
- External Foil Back Insulation	EX
- Earthquake Tabs	EQT

AIR BALANCING DEVICES

Round Neck

- Radial Sliding Blade Damper	4250
- Radial Opposed Blade Damper	4275
- Butterfly Damper	4675
- Equalizing Grid	EGR
- Damper/Equalizing Grid	DEGR

Square Neck

- Opposed Blade Damper	OBD
- Equalizing Grid	EGL
- Damper/Equalizing Grid	DEGL

FINISH

- Appliance White (default)	AW
- Special Custom Color	SP
- AW Face/Black Backpan	BA

FRAME TYPE

- T-Bar Lay-in	L
- Surface Mount	S
- Spline	SP
- Metal Pan Snap-in	M
- Finline®	F

Notes:

1. If more than one accessory is required, list in order.

SUGGESTED SPECIFICATION:

Models 4320F, 4325F – Steel

Furnish and install **Nailor Model** (select one) **4320F Flush Face** or **4325F Drop Face, Fixed Pattern Perforated Supply Ceiling Diffusers** of the sizes and capacities as shown on the plans and air distribution schedules. The diffuser shall have a heavy gauge, stamped corrosion-resistant steel backpan with a high neck collar that is round or square as specified. A corrosion-resistant steel perforated face shall have 3/16" (5) dia. holes on 1/4" (6) staggered centers, providing 51% free area. Mounted at the neck of the diffuser shall be a square, stamped curved vane deflector that is fixed in a 4-way throw pattern, so performance will remain constant. The face shall be removable, hinged and include quick-release spring latches allowing easy access for cleaning (and adjusting the optional damper). The finish shall be AW Appliance White baked enamel (optional finishes are available).

The manufacturer shall provide published performance data for the diffuser, which shall be tested in accordance with ANSI/ASHRAE Standard 70 – 1991.

Models 4320FA, 4325FA – Aluminum Face

Furnish and install **Nailor Model** (select one) **4320FA Flush Face** or **4325FA Drop Face, Fixed Pattern Perforated Supply Ceiling Diffusers** of the sizes and capacities as shown on the plans and air distribution schedules. The diffuser shall have a heavy gauge, stamped corrosion-resistant steel backpan with a high neck collar that is round or square as specified. An aluminum perforated face shall have 3/16" (5) dia. holes on 1/4" (6) staggered centers, providing 51% free area. Mounted at the neck of the diffuser shall be a square, stamped curved vane deflector that is fixed in a 4-way throw pattern, so performance will remain constant. The face shall be removable, hinged and include quick-release spring latches allowing easy access for cleaning (and adjusting the optional damper). The finish shall be AW Appliance White baked enamel (optional finishes are available).

The manufacturer shall provide published performance data for the diffuser, which shall be tested in accordance with ANSI/ASHRAE Standard 70 – 1991.

Performance Data

Models 4320F, 4320FA • 24 x 24 (600 x 600) Module Size • Round Neck

Nominal Neck Size	Neck Velocity, FPM		300	400	500	600	700	800	900
	VP	TP	.006	.010	.016	.023	.031	.040	.051
6" Dia.	Flow Rate, CFM		60	80	95	115	135	155	175
	T	4-Way	1-2-4	2-3-6	2-3-7	3-4-7	3-5-8	4-6-9	4-6-9
3-Way		1-2-5	2-3-7	2-4-8	3-5-9	4-6-9	4-7-10	5-7-11	
2-Way		2-3-7	3-4-9	4-6-11	4-7-12	5-8-13	6-9-14	7-11-15	
1-Way		2-4-8	3-5-11	4-7-13	5-8-15	6-9-16	7-11-17	8-12-18	
NC		—	—	17	23	28	33	36	
8" Dia.	Flow Rate, CFM		105	140	175	210	245	280	315
	T	4-Way	2-3-6	2-4-8	3-5-9	4-6-10	4-7-11	4-8-12	5-9-12
3-Way		2-3-7	3-4-9	3-5-11	4-7-12	5-8-13	6-9-14	7-10-14	
2-Way		3-4-9	4-6-13	5-8-15	6-9-17	7-11-18	8-13-20	9-14-21	
1-Way		3-5-11	5-7-15	6-9-18	7-11-21	8-13-22	10-15-24	11-17-25	
NC		—	—	20	26	31	36	39	
10" Dia.	Flow Rate, CFM		165	215	270	325	380	435	490
	T	4-Way	2-3-7	3-5-10	4-6-12	5-7-13	5-8-14	6-10-15	7-11-16
3-Way		2-4-8	3-5-11	4-7-13	5-8-15	6-10-16	7-11-17	8-13-18	
2-Way		4-6-12	5-8-16	6-10-20	8-12-22	9-14-23	10-16-25	12-18-27	
1-Way		4-7-14	6-9-18	7-11-23	9-14-26	11-16-28	12-18-29	14-22-31	
NC		—	15	23	29	34	38	40	
12" Dia.	Flow Rate, CFM		235	315	390	470	550	625	705
	T	4-Way	3-4-9	4-6-12	5-7-14	6-9-15	7-10-17	8-12-18	9-13-20
3-Way		3-5-10	4-7-14	5-8-16	7-10-18	8-12-20	9-14-22	10-15-23	
2-Way		4-7-14	6-9-20	8-12-24	9-14-26	11-17-28	13-20-30	14-23-32	
1-Way		5-8-17	7-11-23	9-14-28	11-17-31	13-20-33	15-23-35	17-26-37	
NC		—	16	24	30	35	39	41	
14" Dia.	Flow Rate, CFM		320	425	535	640	750	855	960
	T	4-Way	3-5-10	4-7-14	5-8-16	7-10-18	8-12-21	9-14-22	10-16-23
3-Way		4-6-12	5-8-16	6-10-20	8-12-22	9-14-24	10-16-25	12-18-27	
2-Way		5-8-17	7-11-24	9-14-28	11-17-30	13-21-33	15-24-35	17-26-37	
1-Way		6-9-20	8-13-27	11-16-33	13-20-36	15-24-38	17-27-41	20-30-43	
NC		—	18	26	32	37	41	43	
15" Dia.	Flow Rate, CFM		370	490	615	740	860	985	1100
	T	4-Way	3-6-10	4-2-14	5-8-17	8-10-19	8-13-21	10-14-23	10-16-24
3-Way		4-6-12	6-8-17	6-11-21	8-13-22	10-14-25	11-16-26	13-18-28	
2-Way		4-8-17	7-12-25	9-15-30	11-18-31	13-22-34	16-25-35	17-27-38	
1-Way		6-9-20	8-14-28	12-17-34	14-21-37	16-24-39	18-27-42	17-31-43	
NC		—	19	27	33	38	42	44	
16" Dia.	Flow Rate, CFM		420	560	700	835	975	1115	1255
	T	4-Way	4-6-12	5-8-16	6-10-20	8-12-22	9-14-23	10-16-25	12-18-26
3-Way		4-7-14	6-9-18	7-11-23	9-14-25	10-16-27	12-18-29	14-22-30	
2-Way		6-9-20	8-13-27	10-16-32	13-20-35	15-24-37	17-27-40	20-30-42	
1-Way		7-11-23	10-15-31	12-18-37	15-23-41	17-27-44	21-31-47	23-35-50	
NC		—	21	28	34	39	43	45	

D
CEILING DIFFUSERS

For performance notes, see page D162.

Performance Data

Models 4320F, 4320FA • 24 x 24 (600 x 600) Module Size • Square Neck

Nominal Neck Size	Neck Velocity, FPM		300	400	500	600	700	800	900
	VP		.006	.010	.016	.023	.031	.040	.051
	TP		.025	.045	.070	.100	.137	.179	.226
6 x 6	Flow Rate, CFM		75	100	125	150	175	200	225
	T	4-Way	1-2-5	2-3-7	3-4-8	3-5-8	4-6-9	5-7-10	5-7-11
		3-Way	2-3-6	2-4-8	3-5-11	4-6-12	5-7-13	5-8-14	6-10-15
		2-Way	3-4-9	4-6-12	5-7-15	6-9-17	7-10-20	8-12-21	9-14-22
		1-Way	3-5-10	4-7-14	6-9-18	7-10-21	8-12-23	9-14-24	10-16-26
NC		—	—	18	24	29	34	37	
8 x 8	Flow Rate, CFM		135	175	220	265	310	355	400
	T	4-Way	2-3-6	3-4-9	3-5-10	4-6-11	5-8-12	6-9-13	6-10-14
		3-Way	2-3-7	3-5-10	4-6-12	5-7-13	6-9-14	7-10-15	7-11-16
		2-Way	3-5-11	4-7-14	6-9-17	7-11-20	8-13-21	9-14-23	11-16-24
		1-Way	4-6-12	5-8-17	7-10-21	8-12-23	9-14-25	11-17-27	12-20-28
NC		—	—	21	27	32	37	40	
10 x 10	Flow Rate, CFM		210	275	345	415	485	555	625
	T	4-Way	2-4-8	3-5-11	4-7-13	5-8-14	6-10-16	7-11-17	8-12-18
		3-Way	3-4-9	4-6-13	5-8-15	6-9-17	7-11-18	8-13-20	9-14-22
		2-Way	4-6-13	6-9-18	7-11-22	9-13-25	10-16-26	12-18-28	13-21-30
		1-Way	5-8-16	7-10-22	8-13-26	10-16-29	12-18-31	14-22-33	16-25-35
NC		—	16	24	30	35	39	41	
12 x 12	Flow Rate, CFM		300	400	500	600	700	800	900
	T	4-Way	3-5-10	4-6-13	5-8-16	6-10-17	8-12-20	9-13-21	10-15-22
		3-Way	3-5-11	5-7-15	6-9-18	7-11-21	9-13-23	10-15-24	11-17-26
		2-Way	5-8-16	7-11-23	9-13-27	11-16-29	13-20-32	14-23-34	16-25-36
		1-Way	6-9-20	8-12-26	10-16-31	12-20-34	14-23-37	17-26-40	22-31-44
NC		—	17	25	31	36	40	42	
14 x 14	Flow Rate, CFM		410	545	680	815	955	1090	1360
	T	4-Way	1-1-6	1-3-8	2-4-11	3-6-13	4-7-15	5-8-17	7-11-22
		3-Way	1-3-10	2-6-14	4-9-18	6-10-21	8-12-26	9-14-29	11-18-37
		2-Way	2-5-14	4-9-19	7-12-24	9-14-30	11-17-35	13-19-40	16-24-47
		1-Way	3-8-17	6-11-23	9-14-30	11-17-36	13-20-42	15-23-48	19-30-54
NC		—	19	27	33	38	42	44	
15 x 15	Flow Rate, CFM		470	625	780	935	1095	1250	1405
	T	4-Way	4-6-12	5-8-17	7-10-21	8-12-23	10-15-25	11-17-26	12-20-28
		3-Way	4-7-14	6-9-20	8-12-24	9-14-26	11-17-28	13-20-30	14-23-32
		2-Way	6-10-21	9-13-28	11-17-33	13-21-37	16-25-40	18-28-42	21-32-45
		1-Way	8-12-25	10-16-33	13-21-39	16-25-43	18-29-46	22-33-49	25-37-53
NC		—	20	28	33	39	43	45	
16 x 16	Flow Rate, CFM		530	710	890	1065	1245	1420	1600
	T	4-Way	4-7-14	5-9-18	7-10-20	9-13-24	10-16-26	10-19-28	13-21-29
		3-Way	4-7-17	6-10-21	8-12-24	10-15-28	11-20-30	13-22-32	17-24-34
		2-Way	7-10-23	10-14-29	11-17-34	15-22-36	18-28-43	20-30-44	24-34-50
		1-Way	8-12-26	11-17-33	14-21-40	18-25-45	21-32-50	23-38-53	29-40-56
NC		—	22	29	35	40	44	45	

CFM - cubic feet per minute
FPM - feet per minute velocity
TP - total pressure - inches w.g.
VP - velocity pressure - inches w.g.
T - throw in feet
NC - Noise Criteria (values) based on 10 dB room absorption, re 10⁻¹² watts.

Performance Notes:
 1. Throws are given at 150, 100 and 50 fpm terminal velocities under isothermal conditions.
 2. Data derived from tests conducted in accordance with ANSI/ASHRAE Standard 70 – 1991.

Balancing:
 It is recommended that a commercially available 'Flow Hood' is used for field balancing. The airflow meter directly reads average flow rate with great accuracy at all volumes. It is a much faster and more accurate alternative to time consuming multiple velocity readings, eliminating the use of Ak factors and the calculations required to convert the average velocity into airflow.