

## ALUMINUM EGGCRATE GRILLES AND REGISTERS

### • EXHAUST AND RETURN

#### Model:

#### 51EC

- Suffix '-O' adds a steel opposed blade damper
- Suffix '-OA' adds an aluminum opposed blade damper

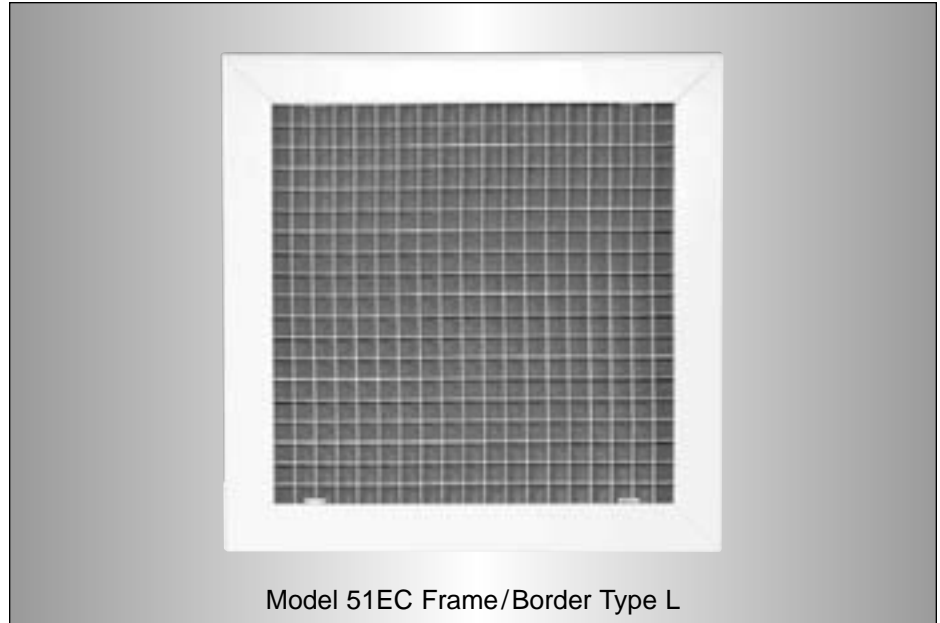

Model 51EC Frame/Border Type L

**Model 51EC Grilles and Registers** have grid cores capable of transferring or returning high air volumes at minimum pressure requirements. They match in appearance the grid louvers on parabolic light fixtures and are available to suit both lay-in T-Bar openings in suspended grid ceilings and overlap openings in hard ceilings and walls.

**Frame/Border Type S Surface Mount** – This style has a flanged frame with an overall face dimension that is 1 3/4" (44) larger than the listed duct size. It is furnished as standard with countersunk screw holes and mounting screws. Available with optional opposed blade damper.

**Frame/Border Type L Lay-in T-Bar** – This style is similar to above, but is sized on the overall face dimension to suit standard lay-in T-Bar ceiling modules and is supplied less screw holes. It is the model of choice for ducted return air applications. The nominal duct size is 2" (51) smaller than the ceiling module. When installed, the frame/border is partially visible within the perimeter of the ceiling opening and provides a visually appealing architectural finish. Available with optional opposed blade damper.

**Frame/Border Type A Lay-in T-Bar, Concealed Angle Frame** – This style has a narrow corrosion-resistant steel frame that surrounds the eggcrate core and is invisible when installed in standard lay-in T-Bar ceilings. It is suited for non-ducted plenum return air applications. The angle frame provides a finished edge to the eggcrate core which may be desirable if it is to be handled on a frequent basis. It also permits the attachment of an optional opposed blade damper.

**Frame/Border Type C Lay-in T-Bar, Core Only** – The most cost effective return air grille for T-Bar ceilings. The ceiling grid conceals the raw edges of the eggcrate when installed. Suitable for use only in non-ducted plenum return air applications. This model is not available with a damper.

Panel mounting is also available in an assortment of styles to suit most other ceiling types. Refer to page number G171 in the Options and Accessories section for further information.

#### FEATURES:

- Frame/border Type S has a 1 1/4" (32) face border with a 1" (25) overlap margin, furnished with countersunk screw holes and mounting screws. Type NF Narrow frame with 1" (25) face border optional. Concealed mounting is optional.
- Aluminum construction – heavy gauge extruded aluminum frames mechanically interlocked with reinforced mitered corners.
- Grid cores are aluminum. Standard core size is 1/2" x 1/2" x 1/2" (13 x 13 x 13) with mechanically locked-in margins, or available as core only. Optional core sizes are 1/2" x 1/2" x 1" (13 x 13 x 25) and 1" x 1" x 1" (25 x 25 x 25).
- Steel or aluminum integral dampers are opposed blade design with a screwdriver slot operator.
- AW Appliance White baked enamel finish is standard. Other finishes are available.
- Available from 4" x 4" to 48" x 48" (102 x 102 to 1219 x 1219) in most models.

## Dimensional Data

### 51EC Series Eggcrate Return and Exhaust

**G**

Top view dimensions: NOMINAL + 1 3/4" (44) STD.\* (width and height), 1 1/4" (32) FACE BORDER STANDARD\* (inner offset).

Side view dimensions: LISTED SIZE = DUCT SIZE D, LISTED SIZE (D) - 1/4" (6), E (height), F (depth), OPTIONAL OPPOSED BLADE DAMPER.

DIMENSION	STANDARD FRAME WITH 1/2 x 1/2 x 1/2 STD. CORE	OPTIONAL NF FRAME AND/OR OPTIONAL CORE
E	7/8" (22)	1 1/4" (32)
F	2 5/8" (67)	3" (76)

\* Optional Type NF Narrow frame with 1" (25) face border and a 3/4" (19) overlap margin. O.A. flange to flange dim. = listed size + 1 1/4" (32).

**Frame/Border Type S – Surface Mount**

**GRILLES AND REGISTERS**

Top view dimensions: CM - 1/4" (6) (width and height), 1 1/4" (32) FACE BORDER (inner offset).

Side view dimensions: CM = CEILING MODULE, CM - 1/4" (6), DUCT = CM - 2" (51), E (height), F (depth), OPTIONAL OPPOSED BLADE DAMPER.

DIMENSION	STANDARD FRAME WITH 1/2 x 1/2 x 1/2 STD. CORE	WITH 1/2 x 1/2 x 1 OR 1 x 1 x 1 OPTIONAL CORE
E	7/8" (22)	1 1/4" (32)
F	2 5/8" (67)	3" (76)

**Frame/Border Type L – Lay-in**

Side view dimensions: CM = CEILING MODULE, CM - 1/4" (6), E (height), F (depth), OPTIONAL OPPOSED BLADE DAMPER.

DIMENSION	STANDARD FRAME WITH 1/2 x 1/2 x 1/2 STD. CORE	WITH 1/2 x 1/2 x 1 OR 1 x 1 x 1 OPTIONAL CORE
E	7/8" (22)	1 1/4" (32)
F	2 5/8" (67)	3" (76)

**Frame/Border Type A – Concealed Angle Frame**

Side view dimensions: CM = CEILING MODULE, CM - 1/4" (6).

**Frame/Border Type C – Core Only**

## STEEL FRAME EGGCRATE GRILLES AND REGISTERS

### • EXHAUST AND RETURN

#### Model:

#### 61EC

- Suffix '-O' adds a steel opposed blade damper

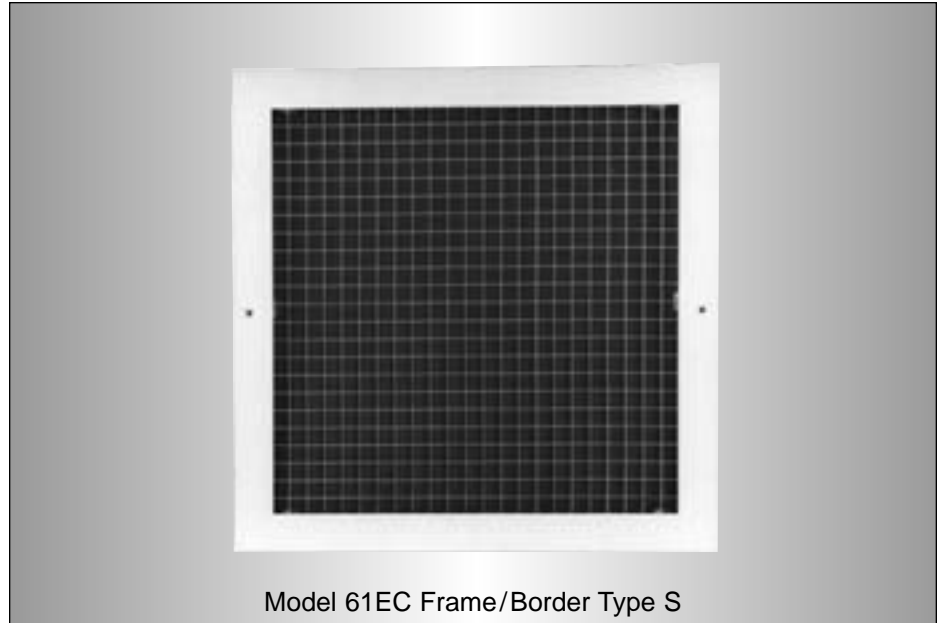

Model 61EC Frame/Border Type S

**Model 61EC Grilles and Registers** have grid cores capable of transferring or returning high air volumes at minimum pressure requirements. They match in appearance the grid louvers on parabolic light fixtures and are available to suit both lay-in T-Bar openings in suspended grid ceilings and overlap openings in hard ceilings and walls.

**Frame/Border Type S Surface Mount** – This style has a flanged frame with an overall face dimension that is 1 3/4" (44) larger than the listed duct size. It is furnished as standard with countersunk screw holes and mounting screws. Available with optional opposed blade damper.

**Frame/Border Type L Lay-in T-Bar** – This style is similar to above, but is sized on the overall face dimension to suit standard lay-in T-bar ceiling modules and is supplied less screw holes. It is the model of choice for ducted return air applications. The nominal duct size is 2" (51) smaller than the ceiling module. When installed, the frame/border is partially visible within the perimeter of the ceiling opening and provides a visually appealing architectural finish. Available with optional opposed blade damper.

**Frame/Border Type F Narrow Regressed T-Bar** – This style has been specially designed for return air applications to integrate with and compliment "Fineline®" type suspended ceiling systems. It is suited for non-ducted plenum return air applications. The corrosion-resistant steel frame includes a support rail on four sides, which allows for the full area of the ceiling module to be utilized.

Panel mounting is also available in an assortment of styles to suit most other ceiling types. Refer to page number G171 in the Options and Accessories section for further information.

#### FEATURES:

- Cost effective, corrosion-resistant steel is used for the frame.
- Frame/border Type S has a 1 1/4" (32) face border with a 1" (25) overlap margin, furnished with countersunk screw holes and mounting screws. Concealed mounting is optional.
- Heavy gauge, roll-formed frames mechanically interlocked with reinforced mitered corners.
- Grid cores are aluminum. Standard core size is 1/2" x 1/2" x 1/2" (13 x 13 x 13) with mechanically locked-in margins. Optional core sizes are 1/2" x 1/2" x 1" (13 x 13 x 25) and 1" x 1" x 1" (25 x 25 x 25).
- Integral dampers – roll-formed steel blades. Opposed blade design with a screwdriver slot operator.
- AW Appliance White baked enamel finish is standard. Other finishes are available.
- Available from 4" x 4" to 48" x 48" (102 x 102 to 1219 x 1219) in most models.

## Dimensional Data

### 61EC Series Eggcrate Return and Exhaust

**G**

**GRILLES AND REGISTERS**

Top view dimensions: NOMINAL + 1 3/4" (44) (width and height), 1 1/4" (32) FACE BORDER.

Side view dimensions: LISTED SIZE = DUCT SIZE D, LISTED SIZE (D) - 1/4" (6), E, F, OPTIONAL OPPOSED BLADE DAMPER.

DIMENSION	STANDARD FRAME WITH 1/2 x 1/2 x 1/2 STD. CORE	WITH 1/2 x 1/2 x 1 OR 1 x 1 x 1 OPTIONAL CORE
E	7/8" (22)	1 1/4" (32)
F	2 5/8" (67)	3" (76)

**Frame/Border Type S – Surface Mount**

Top view dimensions: CM - 1/4" (6) (width and height), 1 1/4" (32) FACE BORDER.

Side view dimensions: CM = CEILING MODULE, CM - 1/4" (6), DUCT = CM - 2" (51), E, F, OPTIONAL OPPOSED BLADE DAMPER.

DIMENSION	STANDARD FRAME WITH 1/2 x 1/2 x 1/2 STD. CORE	WITH 1/2 x 1/2 x 1 OR 1 x 1 x 1 OPTIONAL CORE
E	7/8" (22)	1 1/4" (32)
F	2 5/8" (67)	3" (76)

**Frame/Border Type L – Lay-in**

Top view dimensions: CM = CEILING MODULE, CM - 5/8" (16), CM - 1/4" (6), 1/4" (6), 1 3/4" OR 1 5/8" (44 OR 41), 5/16" (8), 9/16" (14).

Side view dimensions: E, F, OPTIONAL OPPOSED BLADE DAMPER.

**Narrow Regressed T-Bar Detail**

DIM.	STANDARD FRAME WITH 1/2 x 1/2 x 1/2 STD. CORE	WITH 1/2 x 1/2 x 1 OR 1 x 1 x 1 OPTIONAL CORE
E	7/8" (22)	1 1/4" (32)
F	2 5/8" (67)	3" (76)

**Frame/Border Type F – Narrow Regressed T-Bar**

## STAINLESS STEEL EGGCRATE GRILLES AND REGISTERS

- EXHAUST AND RETURN

### Model:

### 67EC

- Suffix '-O' adds a stainless steel opposed blade damper

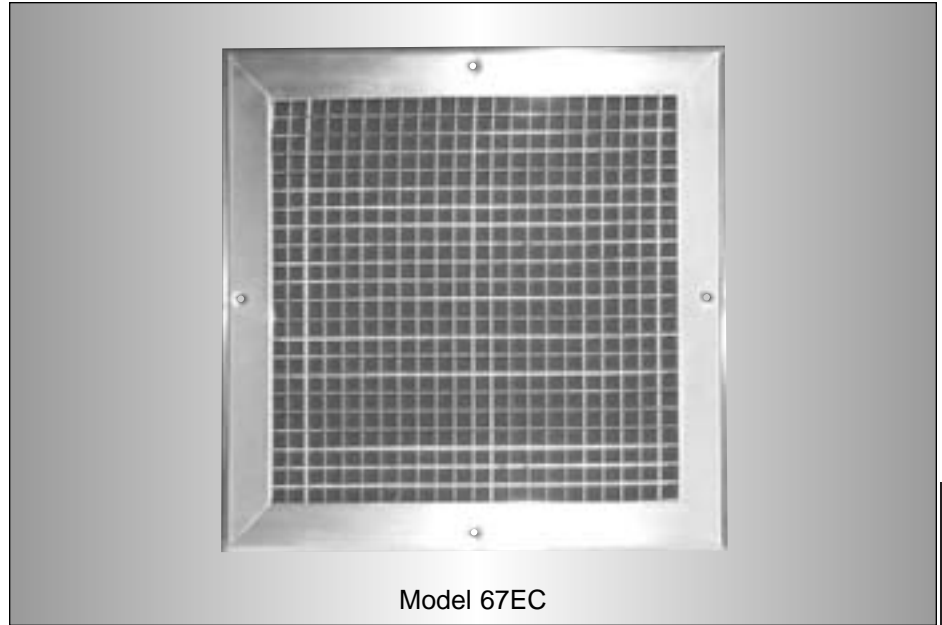

The **Nailor Model Series 67EC Eggcrate Return and Exhaust Grilles and Registers** have grid cores that are capable of transferring or returning high air volumes at minimum pressure requirements. The stainless steel grid core is 1/2" x 1/2" x 1/2" (13 x 13 x 13) and the appearance matches the grid louvers on parabolic light fixtures.

Stainless steel grilles and registers are well suited for applications involving corrosive environments, high humidity or frequent cleaning with strong chemicals. Typical projects include hospitals, cleanrooms, laboratories, industrial and manufacturing facilities.

### FEATURES:

- Type 304 stainless steel construction.
- 1 3/8" (35) wide face border with a 1" (25) overlap margin standard, furnished with type A countersunk screw holes and stainless steel mounting screws.
- Rigid, welded and reinforced frames with hairline mitered corners.
- Grid core is 1/2" x 1/2" x 1/2" (13 x 13 x 13)
- #3 Satin polished finish is standard. AW Appliance White baked enamel finish is optional. Other finishes are available.
- Optional dampers – roll formed stainless steel, opposed blade design with a screwdriver operator.
- Available in sizes from 4" x 4" to 48" x 36" (102 x 102 to 1219 x 914)
- Type 316 stainless steel construction available as an option.

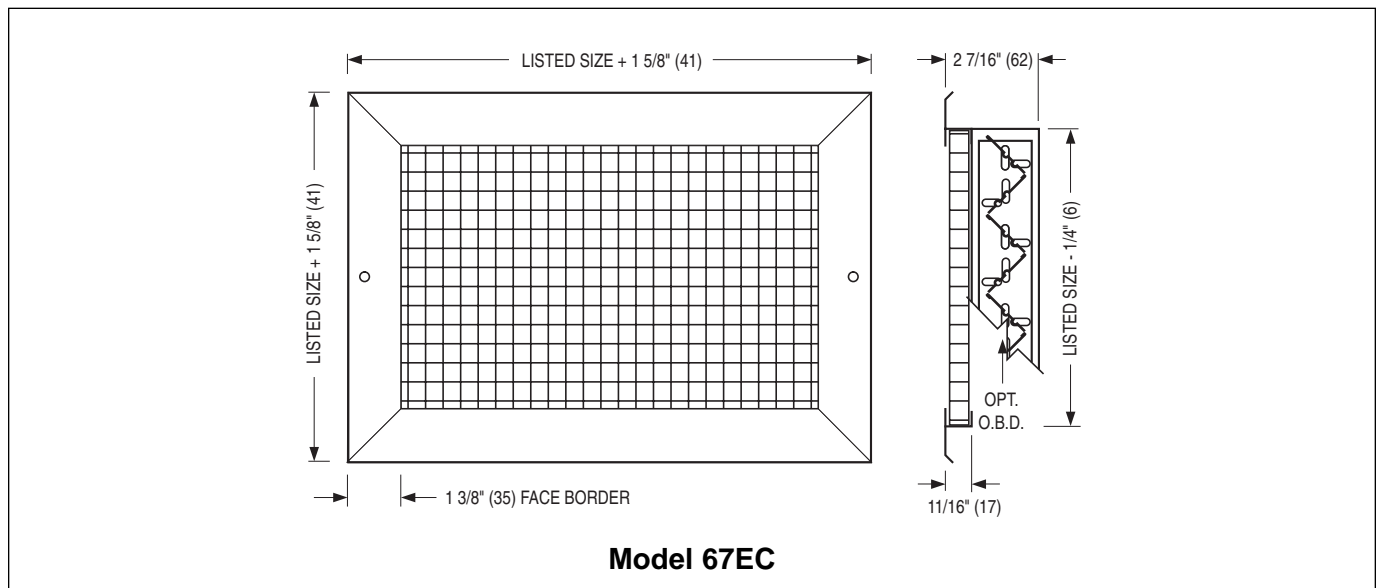

## HOW TO SPECIFY OR TO ORDER

(Show complete Model Number and Size, unless "Default" is desired).

### Aluminum Eggcrate Return and Exhaust Grilles and Registers – Model Series 51EC

51EC - O - 24 x 12 - S - OO - AW - A - CA - —

#### MODEL

- Aluminum 51EC

#### DAMPER (OBD)

- Steel (standard) O  
 - Aluminum OA  
 - No Damper —

#### WIDTH x HEIGHT

inches (mm) x inches (mm)  
 For Type S, NF, PL, SP, MP, FP and TP, W x H = Duct Size  
 For Type L, A and C, W x H = Ceiling Module Size

#### FRAME/BORDER TYPE

##### Surface Mount:

- Standard 1 1/4" (32) (default) S  
 - Narrow 1" (25) NF

##### Ceiling Grid:

- Lay-in T-Bar \* L  
 - Angle Frame A  
 - Core Only C

##### Panel Mount: \*\*

	Steel	Aluminum
- Lay-in T-Bar	PLS or	PLA
- Spline	SPS or	SPA
- Metal Pan	MPS or	MPA
- Fineline® Type	FPS or	FPA
- Tegular	TPS or	TPA

#### ACCESSORIES

- None (default) —  
 - Plaster Sub-frame PF  
 - Earthquake Tabs EQT

#### CORE STYLE

- 1/2 x 1/2 x 1/2 (default) CA  
 - 1/2 x 1/2 x 1 CB  
 - 1 x 1 x 1 CC

#### FASTENING

(only for frame/border types S, NF)  
 - Screw Holes (default) A  
 - Concealed Mounting Straps C  
 - None N

#### FINISH

- Appliance White (default) AW  
 - Aluminum AL  
 - Special Custom Color SP  
 - Satin (clear) Anodized \*\*\* SA

#### CEILING MODULE SIZE

(Use only for panel mounting, frame/border types PL, SP, MP, FP, TP)  
 - None (default) OO

#### Imperial:

12 x 12, 24 x 12, 36 x 12,  
 48 x 12, 20 x 20, 24 x 24,  
 36 x 24, 48 x 24

#### Metric:

300 x 300, 600 x 300, 900 x 300,  
 1200 x 300, 500 x 500, 600 x 600,  
 900 x 600, 1200 x 600

#### Notes:

- For a standard grille with no special requirements, specification is only required as far as the damper selection. The "default" will automatically be selected. For example, an aluminum register, eggcrate core, surface mount with damper, is Model 51EC-O. Unit will be supplied with screw holes and AW Appliance White baked enamel finish.
- \* For Type L Lay-in, grille neck size is ceiling module size - 2" (51).  
 \*\* For Panel mounting, maximum grille neck size is ceiling module size - 3" (76).  
 Refer to Options and Accessories Page No. G171 for dimensional data.  
 \*\*\* Satin anodized finish only available for Frame/Border Types S, NF and L (frame only, mill core).

#### SUGGESTED SPECIFICATION:

Furnish and install **Nailor Model 51EC Eggcrate Return Grilles** of the type and size as shown on the plans and air distribution schedules. The grilles shall have 1/2" x 1/2" x 1/2" (13 x 13 x 13) aluminum grid core and an extruded aluminum frame that has reinforced mitered corners. The finish shall be AW Appliance White baked enamel (optional finishes are available).

(Optional) An opposed blade damper, constructed of heavy gauge corrosion-resistant steel (aluminum is optional) and operable from the face of the grille shall be provided with all units.

The manufacturer shall provide published performance data for the grille, which shall be tested in accordance with ANSI/ASHRAE Standard 70 – 1991.

GRILLES AND REGISTERS

G

## HOW TO SPECIFY OR TO ORDER

(Show complete Model Number and Size, unless "Default" is desired).

### Steel Frame Eggcrate Return and Exhaust Grilles and Registers – Model Series 61EC

**61EC - O - 24 x 12 - S - OO - AW - A - CA - —**

<p><b>MODEL</b></p> <p>- Steel Frame                      61EC</p> <p><b>DAMPER (OBD)</b></p> <p>- Steel (standard)                O</p> <p>- No Damper                        —</p> <p><b>WIDTH x HEIGHT</b></p> <p>inches (mm) x inches (mm)</p> <p>For Type S, PL, SP, MP, FP and TP, W x H = Duct Size</p> <p>For Type L and F, W x H = Ceiling Module Size</p> <p><b>FRAME/BORDER TYPE</b></p> <p>- Surface Mount (default)        S</p> <p><b>Ceiling Grid:</b></p> <p>- Lay-in T-Bar *                    L</p> <p>- Finline®                            F</p> <p><b>Panel Mount: **</b>                    <b>Steel</b></p> <p>- Lay-in T-Bar                        PLS</p> <p>- Spline                                SPS</p> <p>- Metal Pan                            MPS</p> <p>- Finline® Type                      FPS</p> <p>- Tegular                                TPS</p>	<p><b>ACCESSORIES</b></p> <p>- None (default)                    —</p> <p>- Plaster Sub-frame                PF</p> <p>- Earthquake Tabs                 EQT</p> <p><b>CORE STYLE</b></p> <p>- 1/2 x 1/2 x 1/2 (default)        CA</p> <p>- 1/2 x 1/2 x 1                        CB</p> <p>- 1 x 1 x 1                            CC</p> <p><b>FASTENING</b></p> <p>(only for frame / border type S)</p> <p>- Screw Holes (default)            A</p> <p>- Concealed Mounting Straps      C</p> <p>- None                                 N</p> <p><b>FINISH</b></p> <p>- Appliance White (default)        AW</p> <p>- Aluminum                            AL</p> <p>- Special Custom Color              SP</p> <p><b>CEILING MODULE SIZE</b></p> <p>(Use only for panel mounting, frame / border types PL, SP, MP, FP, TP)</p> <p>- None (default)                      OO</p> <p><b>Imperial:</b></p> <p>12 x 12, 24 x 12, 36 x 12, 48 x 12, 20 x 20, 24 x 24, 36 x 24, 48 x 24</p> <p><b>Metric:</b></p> <p>300 x 300, 600 x 300, 900 x 300, 1200 x 300, 500 x 500, 600 x 600, 900 x 600, 1200 x 600</p>
---	--

**G**  
**GRILLES AND REGISTERS**

**Notes:**

- For a standard grille with no special requirements, specification is only required as far as the damper selection. The "default" will automatically be selected. For example, a steel register, eggcrate core, surface mount with damper, is Model 61EC-O. Unit will be supplied with screw holes and AW Appliance White baked enamel finish.
- \* For Type L Lay-in, grille neck size is ceiling module size - 2" (51).  
\*\* For Panel mounting, maximum grille neck size is ceiling module size - 3" (76). Refer to Options and Accessories Page No. G171 for dimensional data.

**SUGGESTED SPECIFICATION:**

Furnish and install **Nailor Model 61EC Eggcrate Return Grilles** of the type and size as shown on the plans and air distribution schedules. The grilles shall have 1/2" x 1/2" x 1/2" (13 x 13 x 13) aluminum grid core and a corrosion-resistant steel frame that has reinforced mitered corners. The finish shall be AW Appliance White baked enamel (optional finishes are available). (Optional) An opposed blade damper, constructed of heavy gauge corrosion-resistant steel and operable from the face of the grille, shall be provided with all units. The manufacturer shall provide published performance data for the grille, which shall be tested in accordance with ANSI/ASHRAE Standard 70 – 1991.

## HOW TO SPECIFY OR TO ORDER

(Show complete Model Number and Size, unless "Default" is desired).

### Stainless Steel Eggcrate Return and Exhaust Grilles and Registers – Model Series 67EC

**G**  
GRILLES AND REGISTERS

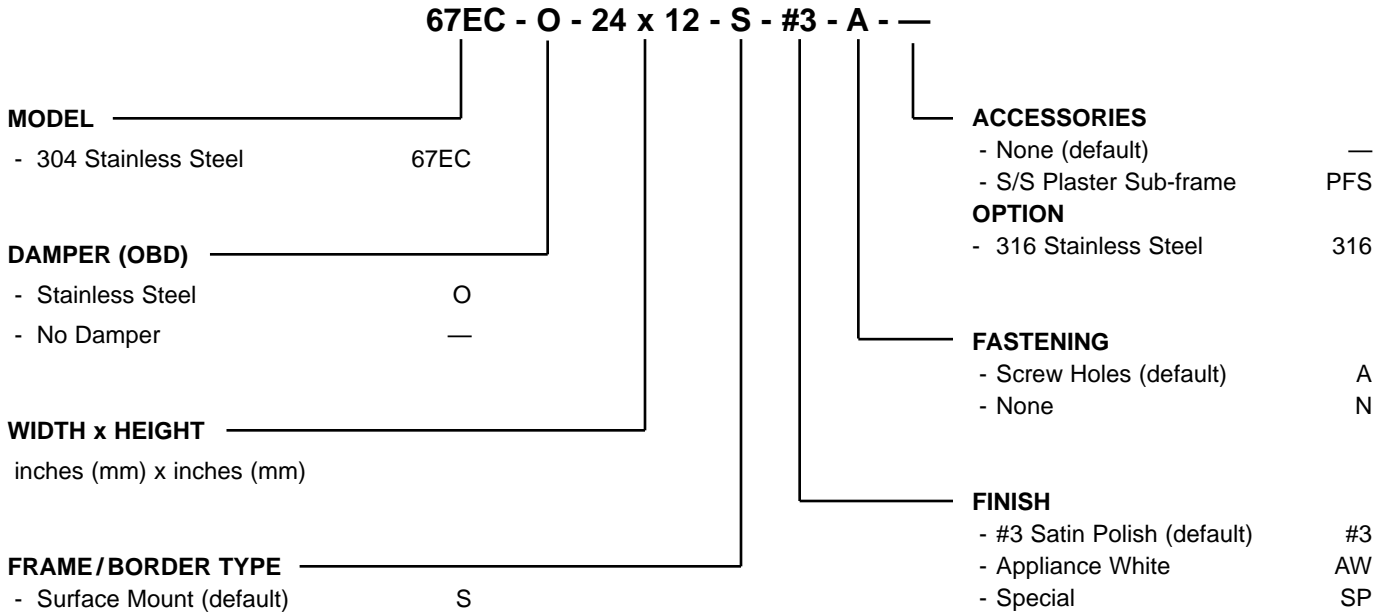

**Notes:**

- For a standard grille with no special requirements, specification is only required as far as the damper selection. The "default" will automatically be selected. For example, a stainless steel register, eggcrate core, and stainless steel damper, is Model 67EC-O. Unit will be supplied with screw holes and #3 satin polished finish.

**SUGGESTED SPECIFICATION:**

Furnish and install **Nailor Model 67EC Eggcrate Return Grilles** of the type and size as shown on the plans and air distribution schedules. The grilles shall be constructed entirely from 304 stainless steel (316 optional). The grid core shall be 1/2" x 1/2" x 1/2" (13 x 13 x 13). The frames shall be constructed of heavy gauge stainless steel and have reinforced mitered corners. All exposed surfaces shall have a #3 satin polished finish.

(Optional) A stainless steel opposed blade damper adjustable from the face of the grille, shall be provided with all units.

The manufacturer shall provide published performance data for the grille, which shall be tested in accordance with ANSI/ASHRAE Standard 70 – 1991.

## Performance Data

Eggcrate Return and Exhaust Grilles and Registers • 5100, 6100 and 6700 Series

Models: 51EC, 61EC, 67EC

51FE, 61FE

Listed Duct Size (inches)	Alternate Size (inches)	Core Area (sq. ft.)	Ak Factor	Core Velocity VP Neg. SP	300	400	500	600	700	800	900	1000	1200	1400
					.006 .011	.010 .019	.016 .030	.022 .043	.031 .059	.040 .078	.051 .098	.062 .120	.090 .173	.122 .236
6 x 6	8 x 4 10 x 4	0.20	0.25	CFM	60	80	100	120	140	160	180	200	240	280
				NC	-	-	-	13	18	22	27	30	36	41
8 x 6	10 x 5 12 x 4	0.27	0.33	CFM	81	108	135	162	189	216	243	270	324	378
				NC	-	-	-	14	19	24	28	31	37	42
10 x 6	12 x 5 16 x 4	0.35	0.41	CFM	105	140	175	210	245	280	315	350	420	490
				NC	-	-	-	15	21	25	29	32	38	43
8 x 8	14 x 5	0.38	0.44	CFM	114	152	190	228	266	304	342	380	456	532
				NC	-	-	-	16	22	25	30	33	39	44
12 x 6	18 x 4	0.42	0.50	CFM	126	168	210	252	294	336	378	420	504	588
				NC	-	-	10	16	22	26	30	33	39	44
12 x 8	16 x 6 24 x 4	0.58	0.66	CFM	174	232	290	348	406	464	522	580	696	812
				NC	-	-	11	18	24	27	31	34	40	45
10 x 10	14 x 7 26 x 4	0.61	0.69	CFM	183	244	305	366	427	488	549	610	732	854
				NC	-	-	12	18	24	27	32	35	41	46
18 x 6	14 x 8    30 x 4 28 x 4	0.65	0.74	CFM	195	260	325	390	455	520	585	650	780	910
				NC	-	-	12	18	24	28	32	35	41	46
12 x 10	16 x 8    20 x 6 24 x 5	0.74	0.82	CFM	222	296	370	444	518	592	666	740	888	1036
				NC	-	-	13	19	25	28	32	36	42	47
12 x 12	14 x 10    24 x 6 18 x 8    38 x 4	0.90	0.99	CFM	270	360	450	540	630	720	810	900	1080	1260
				NC	-	-	14	20	25	29	33	37	43	48
14 x 14	16 x 12    24 x 8 20 x 10    34 x 6	1.24	1.35	CFM	372	496	620	744	868	992	1116	1240	1488	1736
				NC	-	-	15	21	26	30	34	38	44	49
18 x 12	16 x 14    28 x 8 22 x 10    38 x 6	1.37	1.49	CFM	411	548	685	822	959	1096	1233	1370	1644	1918
				NC	-	-	16	21	27	31	34	38	44	49
24 x 10	20 x 12    30 x 8	1.52	1.65	CFM	456	608	760	912	1064	1216	1368	1520	1824	2128
				NC	-	-	16	22	27	31	35	39	45	50
16 x 16	18 x 14    30 x 8 22 x 12	1.64	1.76	CFM	492	656	820	984	1148	1312	1476	1640	1968	2296
				NC	-	-	16	22	27	31	35	39	45	50
24 x 12	18 x 16    30 x 10 20 x 14    36 x 8	1.85	1.98	CFM	555	740	925	1110	1295	1480	1665	1850	2220	2590
				NC	-	-	16	22	27	31	35	39	45	50
18 x 18	20 x 16    28 x 12 24 x 14    32 x 10	2.10	2.23	CFM	630	840	1050	1260	1470	1680	1890	2100	2520	2940
				NC	-	-	16	22	27	32	35	39	45	50
30 x 12	20 x 18    26 x 14 22 x 16    36 x 10	2.32	2.48	CFM	696	928	1160	1392	1624	1856	2088	2320	2784	3248
				NC	-	-	16	23	27	33	36	40	46	51
20 x 20	24 x 18    30 x 14 26 x 16    36 x 12	2.61	2.75	CFM	783	1044	1305	1566	1827	2088	2349	2610	3132	3654
				NC	-	-	17	23	27	33	36	40	46	51
22 x 22	24 x 20    30 x 16 26 x 18    36 x 14	3.17	3.33	CFM	951	1268	1585	1902	2219	2536	2853	3170	3804	4438
				NC	-	-	17	24	28	33	37	41	47	52
30 x 18	24 x 22    40 x 14 34 x 16	3.54	3.71	CFM	1062	1416	1770	2124	2478	2832	3186	3540	4248	4956
				NC	-	-	18	24	29	33	37	41	47	52
24 x 24	26 x 22    32 x 18 28 x 20    36 x 16	3.79	3.96	CFM	1137	1516	1895	2274	2653	3032	3411	3790	4548	5306
				NC	-	11	18	25	30	34	38	42	48	53
36 x 18	32 x 20    46 x 14 40 x 16	4.29	4.46	CFM	1287	1716	2145	2574	3003	3432	3861	4290	5148	6006
				NC	-	11	18	25	30	34	38	42	48	53
26 x 26	28 x 24    48 x 14	4.47	4.65	CFM	1341	1788	2235	2682	3129	3576	4023	4470	5364	6258
				NC	-	12	19	26	31	35	39	43	49	54
30 x 24	28 x 26    36 x 20 32 x 22    40 x 18	4.77	4.95	CFM	1431	1908	2385	2862	3339	3816	4293	4770	5724	6678
				NC	-	12	20	26	31	35	39	43	49	54
28 x 28	30 x 26    40 x 20 36 x 22	5.20	5.39	CFM	1560	2080	2600	3120	3640	4160	4680	5200	6240	7280
				NC	-	13	20	26	31	36	39	43	49	54
36 x 24	30 x 28    44 x 20 40 x 22	5.74	5.94	CFM	1722	2296	2870	3444	4018	4592	5166	5740	6888	8036
				NC	-	13	21	27	32	36	40	43	50	55
30 x 30	34 x 26    48 x 20 38 x 24	5.99	6.19	CFM	1797	2396	2995	3594	4193	4792	5391	5990	7188	8386
				NC	-	14	21	27	32	36	40	44	50	55

GRILLES AND REGISTERS

## Performance Data

Eggcrate Return and Exhaust Grilles and Registers • 5100, 6100 and 6700 Series

Models: 51EC, 61EC, 67EC

51FE, 61FE

Listed Duct Size (inches)	Alternate Size (inches)	Core Area (sq. ft.)	Ak Factor	Core Velocity VP Neg. SP	300	400	500	600	700	800	900	1000	1200	1400
					.006 .011	.010 .019	.016 .030	.022 .043	.031 .059	.040 .078	.051 .098	.062 .120	.090 .173	.122 .236
32 x 32	36 x 30 46 x 22 38 x 28	6.84	7.04	CFM	2052	2736	3420	4104	4788	5472	6156	6840	8208	9576
				NC	-	14	22	27	33	37	41	44	50	55
48 x 24	34 x 34 38 x 30 36 x 32 48 x 28	7.69	7.92	CFM	2307	3076	3845	4614	5383	6152	6921	7690	9228	10766
				NC	-	15	23	28	33	37	42	45	51	56
36 x 36	38 x 34 46 x 28 42 x 30 48 x 26	8.69	8.91	CFM	2607	3476	4345	5214	6083	6952	7821	8690	10428	12166
				NC	-	15	23	29	34	38	42	45	51	56
38 x 38	42 x 34 48 x 30 44 x 34	9.70	9.93	CFM	2910	3880	4850	5820	6790	7760	8730	9700	11640	13580
				NC	-	16	23	29	34	38	43	46	52	57
40 x 40	42 x 36 48 x 32 46 x 34	10.77	11.00	CFM	3231	4308	5385	6462	7539	8616	9693	10770	12924	15078
				NC	-	16	23	29	35	39	44	47	53	58
42 x 42	44 x 40 48 x 36 46 x 38	11.89	12.13	CFM	3567	4756	5945	7134	8323	9512	10701	11890	14268	16646
				NC	-	17	24	30	35	39	44	47	53	58
44 x 44	46 x 42	13.07	13.31	CFM	3921	5228	6535	7842	9149	10456	11763	13070	15684	18298
				NC	-	17	24	30	35	40	44	47	53	58
46 x 46		14.30	14.55	CFM	4290	5720	7150	8580	10010	11440	12870	14300	17160	20020
	NC			10	18	25	31	36	40	44	47	53	59	
48 x 48		15.59	15.84	CFM	4677	6236	7795	9354	10913	12472	14031	15590	18708	21826
	NC			10	18	25	31	36	40	44	47	53	59	

CFM - cubic feet per minute

VP - velocity pressure - inches w.g.

Neg. SP - negative static pressure - inches w.g.

NC - Noise Criteria values are based on 10 dB room absorption, re 10<sup>-12</sup> watts.

Core Velocity is in feet per minute.

### Performance Notes:

1. Grille tested without damper. Apply the following corrections for addition of opposed blade damper to grille:

**Neg. SP** Listed Value x 1.10.

**NC** Add 5 dB to listed value.

2. Data derived from tests conducted in accordance with ANSI/ASHRAE Standard 70 – 1991.

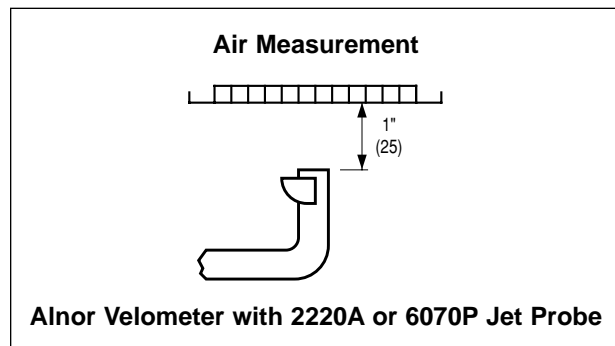

### Airflow Measurements

- Balancing factors are applicable with or without dampers, providing uniform airflow exists into grille or register.
- Take velocity readings at a number of locations on the inlet face (a minimum of 4), while positioning probe as shown above, one inch out from the face.
- Total the various velocity readings and divide by the number of readings taken to arrive at an average inlet velocity (V<sub>k</sub> in FPM).
- Calculate the airflow (CFM) by multiplying the average velocity by the appropriate Ak factor.  
Airflow (CFM) = Average velocity (V<sub>k</sub>) x Ak.

**G**

**GRILLES AND REGISTERS**