

- FOR ROUND DUCT
- FOR HIGH PRESSURE SYSTEMS
- HEAVY DUTY SADDLE AND TURRET

MODEL: 0895



Suitable for use in high pressure round duct systems, Nailor Model 0895 turret style access doors provide heavy duty construction with easy opening. Features include an all-welded turret box and saddle formed to duct radius, and a high-pressure 0800 Series access door that is caulked and fastened to turret. Zinc plated progressive camlocks and bulb type door gasket provide a secure, tight seal.

FOR USE IN HIGH PRESSURE DUCT SYSTEMS

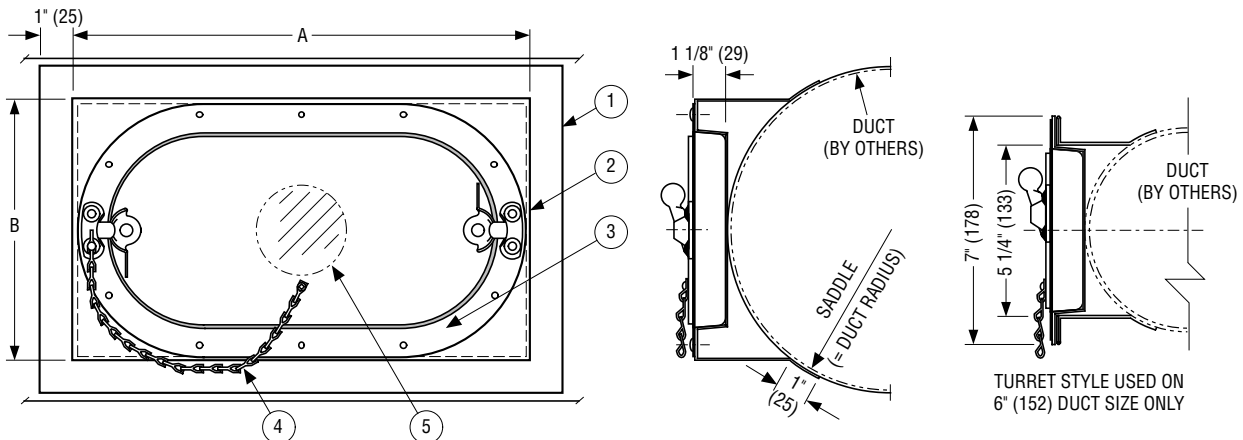

DIMENSIONAL DATA:

DUCT DIAMETER	NOMINAL DOOR SIZE	TURRET DIMENSIONS (A x B)	OPTIONAL VIEWPORT
6 to 12 (152 to 305)	8 x 5 (203 x 127)	10 x 7 (254 x 178)	N/A
8 to 20 (203 to 508)	12 x 6 (305 x 152)	14 1/4 x 8 1/4 (362 x 209)	2 3/4 DIA. (70)
12 to 24 (305 to 610)	18 x 10 (457 x 254)	20 1/4 x 12 1/4 (514 x 311)	5 1/2 DIA. (140)
16 to 36 (406 to 914)	21 x 14 (533 x 356)	23 1/4 x 16 1/4 (590 x 413)	5 1/2 DIA. (140)
24 to 60 (610 to 1524)	25 x 17 (635 x 432)	27 1/4 x 19 1/4 (692 x 489)	5 1/2 DIA. (140)

CONSTRUCTION DETAILS:

1. 16 gauge (1.6) galvanized steel saddle formed to duct radius.
2. Turret box welded to saddle.
3. High pressure access door caulked and screwed or riveted to turret.

OPTIONS:

4. Safety chain (optional).
5. Viewport (optional; not available on size 8 x 5 (203 x 127)).

LEAKAGE INFORMATION:

Maximum allowable leakage at 8" w.g. (2 kPa):
 8" x 5" (23 x 127): 0.036 cfm (1.02 l/min.)
 12" x 6" (304 x 152): 0.064 cfm (1.8 l/min.)
 18" x 10" (457 x 254): 0.133 cfm (3.78 l/min.)
 21" x 14" (533 x 356): 0.206 cfm (5.82 l/min.)
 25" x 17" (635 x 432): 0.286 cfm (8.1 l/min.)

HOW TO SPECIFY OR TO ORDER

DUCT ACCESS DOORS

MODEL SERIES 0890 LOW PRESSURE ROUND DUCT ACCESS DOORS

SUGGESTED SPECIFICATION:

Provide and install, as shown on plans and/or schedules and at each fire damper location, access doors for low pressure round duct work, of suitable size as indicated. Door shall be formed to circumference of duct, from 16 ga. (1.6) galvanized steel, and shall be complete with a continuous piano hinge and zinc plated strikes and catches for secure closing. Door shall be complete with full gasketing to minimize leakage. Standard of acceptance: Nailor Industries Model 0890.

HOW TO ORDER:

Order by duct size (diameter).

MODEL SERIES 0895 HIGH PRESSURE TURRET ROUND DUCT ACCESS DOORS

SUGGESTED SPECIFICATION:

Provide and install, as shown on plans and/or schedules and at each fire damper location, access doors for high pressure round duct work, of suitable size as indicated. Door assembly shall be factory installed and caulked onto a 16 ga. (1.6) galvanized steel welded turret and saddle, formed to match duct circumference. Door frame shall be of oval design, die-formed of minimum 22 ga. (0.85) galvanized steel. Door shall be die-formed of minimum 22 ga. (0.85) galvanized steel and be of double skin construction with 1" (25) of insulation fully enclosed within. Bulb type seal shall be integrally fastened to door for positive seal. Manufacturer shall submit leakage data tested to minimum of 8" w.g. (2 kPa). Standard of acceptance: Nailor Industries Model 0895.

HOW TO ORDER:

Order by duct size, and selected door size, then list options (if desired).

	OPTION CODE	DESCRIPTION	
DOOR SIZE:	08	8 x 5 (203 x 127)	Note: Most duct sizes are available with choice of several door sizes. See chart on page i10 for selection.
	12	12 x 6 (304 x 152)	
	18	18 x 10 (457 x 254)	
	21	21 x 14 (533 x 356)	
	25	25 x 17 (635 x 432)	
OPTIONS:	SC	Safety Chain	
	VP	Viewport	