

- PLENUM ACCESS DOOR
- HINGED
- INSULATED
- ULTRA-LOW LEAKAGE

MODEL: 0840-6



Nailor Model 0840-6 provides easy access to larger plenums and equipment housings and is suitable for use in high, medium, or low pressure applications. The insulation and positive seal gasketing provide optimum performance. The hinged 25" x 17" (635 x 432) door and die-cast closure handles provide maximum convenience.

FOR USE IN HIGH, MEDIUM AND LOW PRESSURE PLENUMS

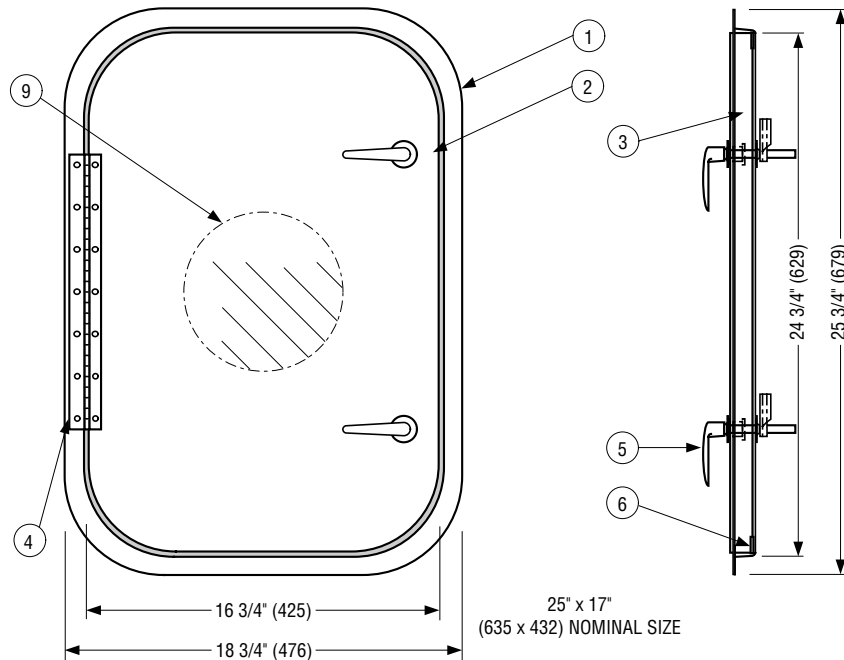

CONSTRUCTION DETAILS:

1. Die-formed 22 ga. (.85) galv. flanged frame for extra strength.
2. Die-formed 22 ga. (.85) galv. door panel for extra strength.
3. 1" (25) insulation with 22 ga. (.85) galvanized backing plate.
4. Zinc plated piano hinge.
5. Die-cast closure handles.
6. Positive seal gasketing.
7. Layout template included.
8. 3/16" (5) dia. pre-punched attachment holes on inner flange for surface mounting (standard).

OPTIONS:

9. Viewport: 5 1/2" (140) dia. (optional).
10. 3/16" (5) dia. pre-punched attachment holes on outer flange for flush mounting (optional).

LEAKAGE INFORMATION:

Maximum allowable leakage at 8" w.g. (2 kPa):
0.286 cfm (8.1 l/min.)

HOW TO SPECIFY OR TO ORDER

DUCT ACCESS DOORS

MODEL 0840-6 PLENUM ACCESS DOOR

SUGGESTED SPECIFICATION:

Provide and install, as shown on plans and/or schedules, plenum access doors meeting or exceeding the following criteria: Frame shall be of oval design, die-formed of minimum 22 ga. (.85) galvanized steel. Door shall be die-formed of minimum 22 ga. (0.85) galvanized steel and be of double skin construction with 1" (25) of insulation fully enclosed within. Door shall be attached to frame with continuous plated steel piano hinge and shall close securely by means of two die-cast closure handles. Bulb type seal shall be integrally fastened to door for positive seal. Manufacturer shall submit leakage data tested to minimum of 8" w.g. (2 kPa). Standard of acceptance: Nailor Industries Model 0840-6.

HOW TO ORDER:

Available in 25 x 17 (635 x 432) size only.
Order Model 0840-6, then list any options (if desired).

	OPTION CODE	DESCRIPTION
OPTIONS:	VP	Viewport
	PO	Pre-punched holes on outer flange

- FOR ROUND DUCT
- FOR LOW PRESSURE SYSTEMS
- HINGED

MODEL: 0890



Nailor Model 0890 is an economical round duct access door, suitable for use in low pressure systems. A continuous piano hinge permits the door to swing open fully, allowing unobstructed access to the duct, while the zinc plated strikes and catches, and polyurethane foam gasketing provide a tight, positive seal.

FOR USE IN LOW PRESSURE DUCT SYSTEMS

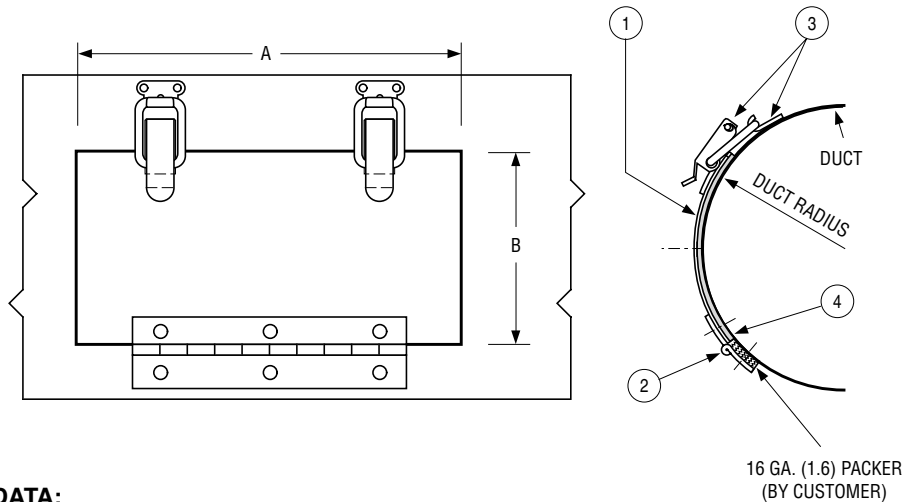

DIMENSIONAL DATA:

DUCT DIAMETER	DOOR SIZE (A x B)
5 (127)	7 x 4 (178 x 102)
6 (152)	8 x 5 (203 x 127)
7 (178)	9 x 6 (229 x 152)
8 (203)	10 x 7 (254 x 178)
9 (229)	11 x 8 (279 x 203)
10 (254)	12 x 9 (305 x 229)
12 (305)	14 x 10 (356 x 254)
14 (356)	16 x 12 (406 x 305)
16 (406)	16 x 12 (406 x 305)
18 (457)	18 x 14 (457 x 356)
20 (508)	18 x 16 (457 x 406)
24 (610)	18 x 16 (457 x 406)

CONSTRUCTION DETAILS:

1. Duct access door 16 ga. (1.6) galvanized steel.
2. Door hinge.
3. Strike and catch. Zinc plated steel.
4. Gasket.
5. Other sizes are available; contact factory.