

# CORRIDOR FIRE / SMOKE DAMPERS • AIRFOIL BLADE

- TUNNEL CORRIDOR FIRE/SMOKE DAMPER
- AIRFOIL BLADE
- ULTRA-LOW LEAKAGE
- UL555 1 HR RATING
- UL555S CLASS I AT 250° OR 350°F

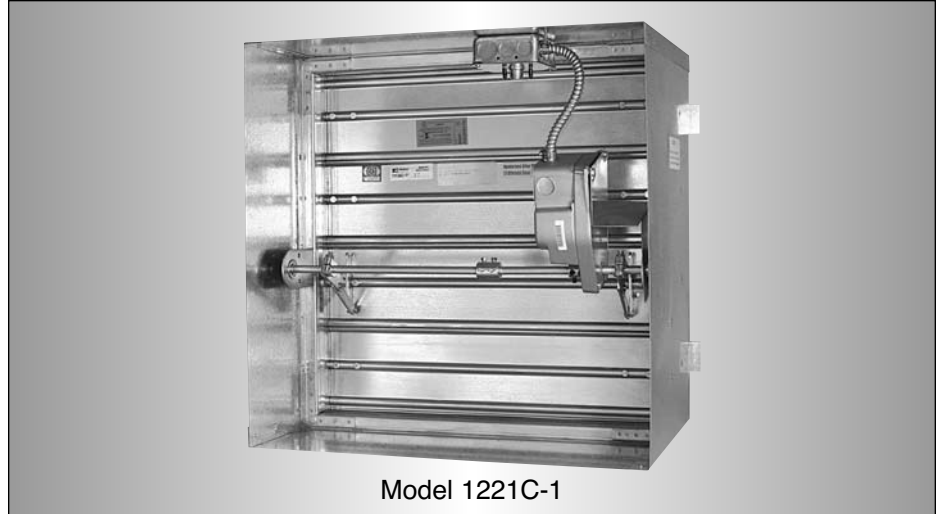

Model 1221C-1

MODELS: 1221C-1  
1221C-2



Nailor Models 1221C-1 and 1221C-2 Tunnel Corridor Combination Fire/Smoke Dampers are for use where ductwork penetrates the ceiling of an interior corridor of a building, creating a horizontal opening that requires protection. Unique interlocking airfoil blade design provides low pressure drop and ultra-low leakage without the use of blade seals that can burn-off during fire conditions. Model 1221C-1 is suitable for use with a steel grille or diffuser when the duct terminates at the ceiling. Model 1221C-2 is suitable for use when the duct is required to continue down past the ceiling level. Each unit is supplied factory mounted in a suitable sleeve complete with upper retaining angles. For applications where the duct terminates at the ceiling, other manufacturers require full length lower retaining angles with minimum 1" (25) ceiling overlap that protrudes past the grille/diffuser frame causing aesthetic difficulties. Model 1221C-1 is provided with lower mounting tabs that are easily covered by available variety of Nailor steel grilles/diffusers, solving this problem. For Model 1221C-2, lower retaining angles are available from Nailor. Either way, Nailor provides complete protection with reduced installation time and cost.

## QUALIFICATIONS:

- UL 555 Classified Corridor Damper, 1 hr. Fire Resistance Rating (File #9492).
- UL 555S Classified Smoke Damper, Leakage Class I at 250°F or 350°F elevated temp. (File #9492).
- California State Fire Marshal: Fire Damper Listing No. 3225-0935:106.
- Meets the requirements of NFPA 90A, NFPA 92A for Fire/Smoke Dampers.
- Meets the requirements of City of Los Angeles, Uniform Building Code.
- Maximum velocity 2000 fpm @ 4" w.g. (up to 4000 fpm @ 8" w.g. with specific actuators. Consult Nailor).

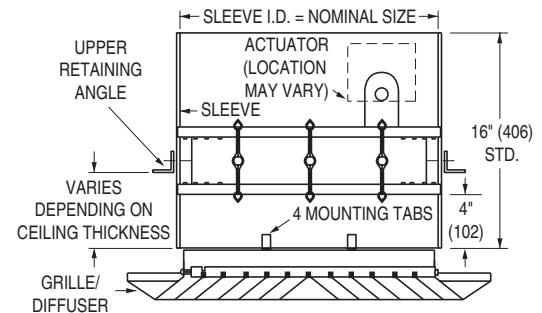

## Model: 1221C-1

### CONSTRUCTION DETAILS:

- FRAME:** 5" x 7/8" x 16 ga. (127 x 22 x 1.6) galvanized steel hat channel.
- BLADES:** 14 ga. (2.0) equivalent galvanized steel formed airfoil on 5 1/2" (140) centers. Opposed action.
- SLEEVE:** 16" x 20 ga. (406 x 1.0) standard.
- UPPER RETAINING ANGLES:** 1 1/2" x 1 1/2" x 16 ga. (38 x 38 x 1.6) galvanized steel (by Nailor).
- LINKAGE:** Concealed in frame.
- BEARINGS:** 1/2" (13) dia. self-lubricating oilite bronze.
- AXLES:** 1/2" (13) dia. plated steel double bolted to blades.
- JAMB SEALS:** Cambered stainless steel.
- HEAT RESPONSIVE DEVICE (CONTROLLED CLOSURE):** 250°F (121°C) standard. 165°F (74°C), 212°F (100°C) and, with ERL only, 350°F (176°C) available.
- MINIMUM SIZE:** 8" x 8" (203 x 203).
- MAXIMUM SIZE:** 24" x 24" (610 x 610).

Model 1221C-1 (for use with Steel Grille/Diffuser)

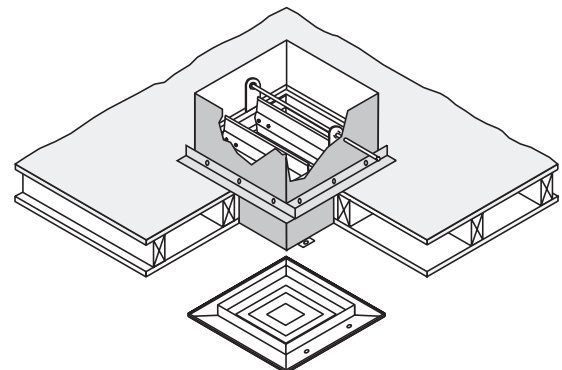

Isometric View of typical Model 1221C-1 in 1 hour wood stud ceiling

G

COMBINATION FIRE/SMOKE DAMPERS

## Model: 1221C-2 (For Ducted Installation)

### CONSTRUCTION DETAILS:

<b>FRAME:</b>	5" x 7/8" x 16 ga. (127 x 22 x 1.6) galvanized steel hat channel.
<b>BLADES:</b>	14 ga. (2.0) equivalent galvanized steel formed airfoil on 5 1/2" (140) centers. Opposed action.
<b>SLEEVE:</b>	16" x 20 ga. (406 x 1.0) standard.
<b>UPPER RETAINING ANGLES:</b>	1 1/2" x 1 1/2" x 16 ga. (38 x 38 x 1.6) galvanized steel (by Nailor).
<b>LOWER RETAINING ANGLES:</b>	1 1/2" x 1 1/2" x 16 ga. (38 x 38 x 1.6) galvanized steel by installing contractor (optionally by Nailor).
<b>LINKAGE:</b>	Concealed in frame.
<b>BEARINGS:</b>	1/2" (13) dia. self-lubricating oilite bronze.
<b>AXLES:</b>	1/2" (13) dia. plated steel double bolted to blades.
<b>JAMB SEALS:</b>	Cambered stainless steel.
<b>HEAT RESPONSIVE DEVICE (CONTROLLED CLOSURE):</b>	250°F (121°C) standard. 165°F (74°C), 212°F (100°C) and, with ERL only, 350°F (176°C) available.
<b>MINIMUM SIZE:</b>	8" x 8" (203 x 203).
<b>MAXIMUM SIZE:</b>	24" x 24" (610 x 610).

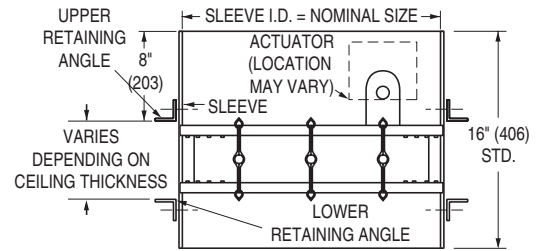

Model: 1221C-2

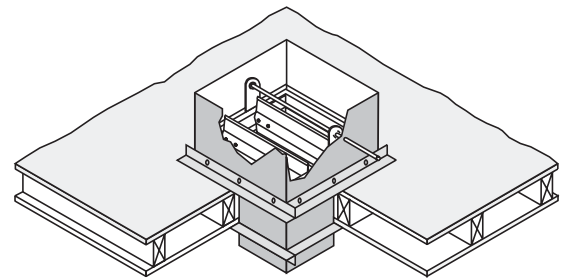

Isometric View of typical Model 1221C-2 in 1 Hour wood stud ceiling.

ERL (Electric Resettable Link) is standard on all dampers with electric actuators. PRL (Pneumatic Replaceable Link) is standard on all dampers with pneumatic actuators.

### LEAKAGE CLASS

The 1221C Series Tunnel Corridor Combination Fire/Smoke Damper has been designed and qualified under UL 555S in order to provide maximum system design flexibility. They are available with a Class I leakage rating with all damper/actuator assemblies having been tested successfully at an elevated temperature of 250°F (121°C) or 350°F (176°C), depending on actuator, under airflow of 2000 fpm (10 m/s) at 4" w.g. (0.995 kPa) (up to 4000 fpm @ 8" w.g. with specific actuators. Consult Nailor).

Leakage Class	Maximum Leakage cfm/ft <sup>2</sup> (m <sup>3</sup> /s/m <sup>2</sup> )	
	@ 1" w.g. (0.249 kPa)	@ 4" w.g. (0.995 kPa)
I	4 (0.020)	8 (0.041)



**CORRIDOR COMBINATION FIRE/SMOKE DAMPERS**

**MODELS: 1221C-1/1221C-2**

**VARIABLES / ACCESSORIES**

<b>VARIABLES:</b>	<b>CODE</b>	<b>DESCRIPTION</b>
<b>LEAKAGE / ELEV. TEMP. RATINGS:</b>	125 135	Class I @ 250°F Class I @ 350°F
<b>CLOSURE DEVICE:</b>	ERL ML4  PRL	Electric Resettable Link MLS-400 Fire Sensor Reopenable Control System Pneumatic Replaceable Link
<b>CLOSURE TEMPERATURE:</b>	165 212 250 350 HL (must select with MLS-400)	165°F (74°C) 212°F (100°C) 250°F (121°C) 350°F (177°C) High=350°F or 250°F/ Low=165°F
<b>SLEEVE LENGTH/GAUGE:</b>	Specify Sleeve Length: Specify Sleeve Gauge:	16" (406) to 28" (711). 20G, 18G, 16G, 14G, 10G
<b>ACTUATORS:</b>	411 811 MS4 MS8 4Y0 F12 F24 412 812 462 GD2 GD1 GD3 296 306	Honeywell ML4115 (120 VAC) Honeywell ML8115 (24 VAC) Honeywell MS4X09 (120 VAC) Honeywell MS8X09 (24 VAC) Honeywell MS4Y09 (230 VAC) Belimo FSNF120 (120 VAC) Belimo FSNF24 (24 VAC) Honeywell MS4120 (120 VAC) Honeywell MS8120 (24 VAC) Honeywell MS4620 (230 VAC) Siemens GGD221 (120 VAC) Siemens GGD121 (24 VAC) Siemens GGD321 (230 VAC) Siemens 331-2961 (25 psi) Siemens 331-3060 (25 psi)
<b>ACTUATOR MOUNTING:</b>	EXT INT	External Mount Internal Mount
<b>ACTUATOR LOCATION:</b>	RH LH	Right-Hand Mount Left-Hand Mount
<b>UPPER ANGLES:</b>	UNM UFM	Not Factory Mounted Factory Mounted
<b>ANGLE LOCATION:</b> (Model 1221C-1 only)	When Upper Angles are Factory Mounted, Specify Upper Angle Location on Sleeve	
<b>ACCESSORIES:</b>	<b>CODE</b>	<b>DESCRIPTION</b>
<b>POSITION INDICATOR:</b>	300	MLS-300 Switch Pack
<b>E.P. SWITCH:</b>	EP1 EP2	120V Siemens 2651008 24Vac Siemens 2651007
<b>LOWER ANGLES:</b> (Model 1221C-2 only)	LNM	Lower Angles supplied loose (not mounted)
<b>TRANSITION COLLARS:</b>	SRT  SRB (Model 1221 C-2 only)  SR2 (Model 1221 C-2 only)	Top Transition for Round Duct Connection - Specify Diameter Bottom Transition for Round Duct Connection - Specify Diameter Both Top and Bottom Transitions For Round Duct - Specify Diameter



**COMBINATION FIRE/SMOKE DAMPERS**

**HOW TO ORDER OR TO SPECIFY**

**CORRIDOR COMBINATION FIRE/SMOKE DAMPERS**

**MODELS: 1221C-1/1221C-2**

**HOW TO ORDER:**

Select model number and size, then select from each variable. Choose accessories as desired. See previous page for description of variables and accessories.

MODEL	SIZE (W X H)	LEAKAGE/ELEV. TEMP. RATING	CLOSURE DEVICE	CLOSURE TEMP.	SLEEVE LENGTH *	SLEEVE GAUGE *	ACTUATOR	ACTUATOR MOUNTING	ACTUATOR LOCATION	UPPER ANGLES	ANGLE LOCATION	ACCESSORIES
1221C-1	ie: 24" x 24"	125	ERL	165		20G		EXT	RH	UNM		300
1221C-2		135	ML4 PRL	212 250 350 HL	SPECIFY LENGTH	18G 16G 14G 10G	ACTUATORS ARE LISTED ON PREVIOUS PAGE	INT	LH	UFM	SPECIFY LOCATION	EP1 EP2 LNM SRB SRT SR2

- Notes: 1. Models 1221C-1 and 1221C-2 are for Horizontal Mount applications only.  
 2. \* Standard sleeve is 16" (406) long x 20 ga. (1.0).  
 3. A wide variety of steel GRILLES/DIFFUSERS are available with Model 1221C-1.  
 See Air Distribution Catalog or consult Nailor for selection assistance.  
 4. MLS-300 Position Indicator is included as part of MLS-400 package.

**SUGGESTED SPECIFICATION:**

Provide and install, as shown on plans and/or schedules, Corridor Dampers meeting or exceeding the following criteria: Frame shall be constructed of 16 ga. (1.6) galvanized steel hat channel with mitered corners reinforced with die-formed corner gussets for strength. Blades shall be 14 ga. (2.0) equivalent galvanized steel formed double skin, airfoil design, on 5 1/2" (140) centers. Dampers shall be of opposed blade configuration with an interlocking blade design that provides complete flame and smoke seal under fire conditions at an elevated temperature of 2000°F (1093°C) when in closed position. Dampers requiring blade seals to maintain leakage class when under elevated temperature conditions are not acceptable. Blades axles shall be 1/2" (13) dia. plated steel, double bolted at each end of blade to ensure positive locking connection. Hex or square friction-fit or press-fit axles are not acceptable. Bearings shall be zero-maintenance, concealed in frame, out of airstream. Jamb seals shall be compression type cambered stainless steel.

Dampers shall meet the requirements of NFPA 90A and 92A. Dampers shall be classified by Underwriters Laboratories and labeled as 1 hour fire resistance rated Corridor Damper under UL 555, and as a Class I Leakage Rated Smoke Damper under UL 555S at an elevated temperature of **(specifier select one)** 250°F (121°C) **or** 350°F (177°C). Each damper shall bear a UL label verifying same. Dampers shall be supplied with factory installed sleeves of minimum 16" (406) length, to be field verified by contractor dependent upon ceiling thickness. Factory sleeves shall be caulked to UL requirements and shall be complete with factory supplied upper retaining angles of minimum 1 1/2" x 1 1/2" x 16 ga. (38 x 38 x 1.6) galvanized steel.

Appropriate electric **or** pneumatic actuators **(specifier select type)** shall be installed by the damper manufacturer in the factory and shall have been tested and classified under UL 555S with the damper, at an elevated temperature of **(specifier select one)** 250°F (121°C) **or** 350°F (177°C). Actuators shall incorporate an OEM internal spring return mechanism. External after-market spring mechanisms are not acceptable. Damper and actuator assembly shall be factory cycled a minimum of three times to ensure correct operation.

Each damper shall be equipped with a UL classified heat responsive device that will cause the damper to close in a controlled manner and lock in a closed position by means of an over center/knee lock linkage when the duct temperature reaches the maximum degradation temperature of the damper/actuator assembly, as required by UL555S. Closure devices that cause instantaneous closure are not acceptable. Damper manufacturer shall submit independent test data verifying pressure drop, leakage characteristics and airflow conditions.

For applications where ductwork terminates at the ceiling, standard of acceptance shall be Nailor Industries Model 1221C-1. For applications where ductwork continues down past ceiling, standard of acceptance shall be Nailor Industries Model 1221C-2.

