

- INTEGRAL SLEEVE FOR USE WITH GRILLE
- PREMIUM PERFORMANCE
- AIRFOIL BLADE
- UL 555 CLASSIFIED DYNAMIC FIRE DAMPER
- UL 555S SMOKE DAMPER

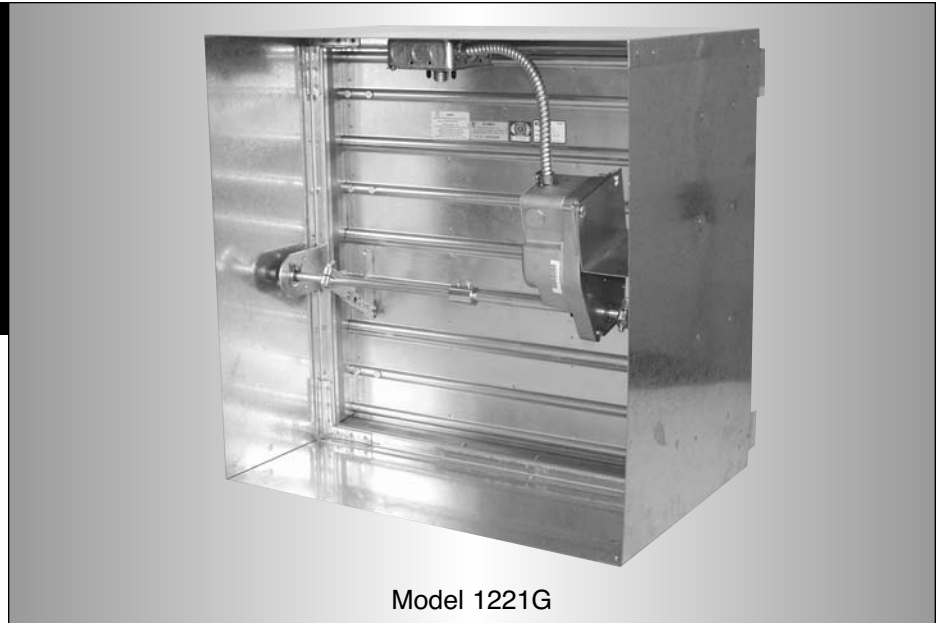

Model 1221G

MODEL: 1221G



G

COMBINATION FIRE/SMOKE DAMPERS

Model 1221G is a high performance combination fire/smoke damper specifically designed for supply or return ducts that terminate at a grille. The special factory sleeve with unique 3/4" (19) grille mounting flanges simplifies installation, saves on field labor and eliminates the requirements for unsightly front retaining angles which commonly protrude from behind the grill. Steel grille with correctly located countersunk screwholes is available from Nailor and installs over and completely hides the mounting flanges. The damper is offset in the sleeve to accommodate a single or double deflection supply air grille, single deflection supply air register or a return air grille or register.

The 1221G offers premium performance with the lowest leakage class available and a low pressure drop well suited to the majority of commercial applications. Unique inter-locking double skin blade design eliminates combustible seals and provides flame and smoke seal under fire conditions at temperatures up to 2000°F.

#### QUALIFICATIONS:

- UL 555 CLASSIFIED DYNAMIC FIRE DAMPER • 1 1/2 hr. Label (File #9492).
- UL 555S CLASSIFIED SMOKE DAMPER (File #9492).  
Leakage Class I or II at 250°F or 350°F elevated temperature.
- Meets NFPA 90A, NFPA 92A, BOCA, SBCCI, UBC and IBC requirements.
- Maximum velocity 2000 fpm @ 4" w.g.

#### CONSTRUCTION DETAILS:

- FRAME:** 5" x 7/8" x 16 ga. (127 x 22 x 1.6) galvanized steel hat channel.
- BLADES:** 14 ga. (2.0) equivalent galvanized steel formed airfoil on 5 1/2" (140) centers. Opposed action.
- SLEEVE:** 16" x 20 ga.. (406 x 1.0) galvanized steel with 3/4" (19) wide grille mounting flanges
- LINKAGE:** Concealed in frame. 12 ga. (2.7) plated steel.
- BEARINGS:** 1/2" (13) dia. self-lubricating oilite bronze.
- AXLES:** 1/2" (13) dia. plated steel double bolted to blades.
- JACKSHAFT:** 1/2" (13) dia. cadmium plated steel.
- JAMB SEALS:** Stainless steel.

#### HEAT RESPONSIVE DEVICE (CONTROLLED CLOSURE):

250°F (121°C) standard. 165°F (74°C), 212°F (100°C) and, with ERL only, 350°F (176°C) available. ERL (Electric Resettable Link) is standard on all dampers with electric actuators. PRL (Pneumatic Replaceable Link) is standard on all dampers with pneumatic actuators.

**MINIMUM SIZE:** 8" x 8" (203 x 203).

**MAXIMUM SIZE:** 24" x 24" (610 x 610)

**IMPORTANT NOTE:** Minimum 6 1/2" (165) wall thickness is required for this installation. Contact factory for non-standard applications.

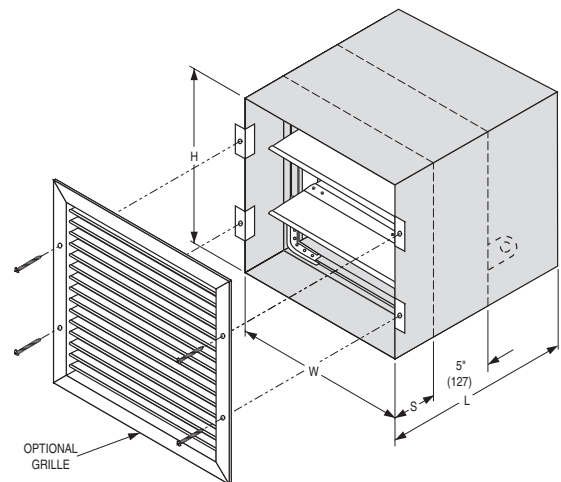

MODEL 1221G

MODEL: 1221G

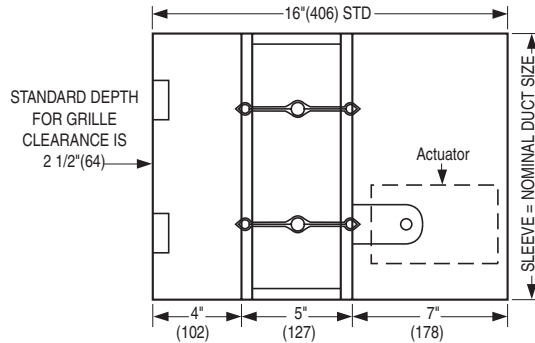

**STANDARD DAMPER/SLEEVE**

## VARIABLES / ACCESSORIES

VARIABLES:	CODE	DESCRIPTION
<b>MOUNTING:</b>	V	Vertical Mount (wall)
	H	Horizontal Mount (floor)
<b>LEAKAGE/ELEV. TEMP. RATINGS:</b>	125	Class I @ 250°F
	135	Class I @ 350°F
	225	Class II @ 250°F
	235	Class II @ 350°F
<b>CLOSURE DEVICE:</b>	ERL	Electric Resettable Link
	ML4	MLS-400 Fire Sensor Reopenable Control System
	PRL	Pneumatic Replaceable Link
<b>CLOSURE TEMPERATURE:</b>	165	165°F (74°C)
	212	212°F (100°C)
	250	250°F (121°C)
	350	350°F (177°C)
	HL (must select with MLS-400)	High=350°F/Low=165°F
<b>SLEEVE LENGTH/GAUGE:</b>	Specify Sleeve Length: Specify Sleeve Gauge:	See Note 1 below 20G, 18G, 16G, 14G, 10G
<b>ACTUATORS:</b>	411	Honeywell ML4115 (120V)
	811	Honeywell ML8115 (24V)
	296	Siemens 331-2961 (25psi)
<b>ACTUATOR MOUNTING:</b>	INT	Internal Mount
	EXT	External Mount
<b>FAIL POSITION:</b>	CL	Damper to Fail Closed
<b>DAMPER LOCATION IN SLEEVE:</b>	L0	Specify Dimension from Sleeve End
<b>ACCESSORIES:</b>	<b>CODE</b>	<b>DESCRIPTION</b>
<b>POSITION INDICATOR:</b>	300	MLS-300 Switch Pack
<b>E.P. SWITCH:</b>	EPI	120V Siemens 2651008
	EP2	24V Siemens 2651007
<b>RETAINING ANGLE:</b>	QS1	One "Quick Set" retaining angle
<b>FLANGED SLEEVE:</b>	TDF1	Flange on One End

Notes: 1. Standard sleeve is 16" (406) long x 20 ga. (1.0), provides a grille clearance depth of 2 1/2 (64), and requires a minimum wall thickness of 6 1/2" (165) (closed damper blades must remain within the plane of the wall/floor). Damper position 'S' may be reduced to accommodate a thinner wall but grille clearance will reduce accordingly.



COMBINATION FIRE/SMOKE DAMPERS

## HOW TO ORDER OR TO SPECIFY

### COMBINATION FIRE/SMOKE DAMPERS

#### MODEL: 1221G

#### HOW TO ORDER:

Select model number and size, then select from each variable. Choose accessories as desired. See previous page for description of variables and accessories.

MODEL	SIZE (W X H)	MOUNTING	LEAKAGE/ELEV. TEMP. RATING	CLOSURE DEVICE	CLOSURE TEMP. *	SLEEVE LENGTH **	SLEEVE GAUGE **	ACTUATOR	ACTUATOR MOUNTING	FAIL POSITION	DAMPER LOCATION IN SLEEVE	ACCESSORIES
1221G	ie: 24" x 24"	V H	125	ERL	165	SPECIFY LENGTH	20G	411	EXT	CL	L0	300
			135	ML4	212		18G	811	INT			EP1
			225	PRL	250		16G	296	EP2			
			235		350		14G		QS1			
				HL	10G				TDF1			

- Notes:
- \* Maximum closure temperature allowed is equal to elevated temperature rating. HL (high/low closure temps.) must be selected when MLS-400 is selected as closure device.
  - \*\* Standard sleeve is 16" (406) long x 20 ga. (1.0), provides a grille clearance depth of 2 1/2" (64), and requires a minimum wall thickness of 6 1/2" (165) (closed damper blades must remain within the plane of the wall/floor). Damper position 'S' may be reduced to accommodate a thinner wall but grille clearance will reduce accordingly.
  - MLS-300 is included as part of MLS-400 package.

#### SUGGESTED SPECIFICATION:

Provide and install, as shown on plans and/or schedules, Combination Fire/Smoke Dampers approved for use with grilles where ductwork design penetrates and terminates at a fire separation. Dampers shall be as manufactured by Nailor Industries and shall meet or exceed the following criteria: Frame shall be constructed of 16 ga. (1.6) galvanized steel hat channel with mitered corners reinforced with die-formed corner gussets for strength. Blades shall be 14 ga. (2.0) equivalent galvanized steel formed double skin, airfoil design, on 5 1/2" (140) centers. Dampers shall be of opposed blade configuration with an interlocking blade design that provides complete flame and smoke seal under fire conditions at an elevated temperature of 2000°F (1093°C) when in closed position. Dampers requiring blade seals to maintain leakage class when under elevated temperature conditions are not acceptable. Blade axles shall be plated steel, double bolted at each end of blade to provide positive locking connection. Hex or square friction-fit, or press-fit axles are not acceptable. Bearings shall be self-lubricating oilite bronze type. Blade linkage shall be zero maintenance, concealed in frame, out of airstream. Jamb seals shall be compression-type stainless steel.

Dampers shall meet the requirements of NFPA 90A, 92A and 92B. Dampers shall be classified by Underwriter's Laboratories and labeled as 1 1/2 hour Dynamic Fire Damper under UL 555, and Class 1 Smoke Damper under UL 555S at an elevated temperature of 250°F (121°C) or 350°F (177°C) (**specifier select one**) for use in dynamic or static Smoke Control Systems. Dampers shall be supplied with 16" (406) long factory installed sleeves and shall be field verified by contractor, dependent on wall thickness. Sleeves shall be caulked to UL requirements and shall be 20 ga. (1.0) galvanized steel with 3/4" (19) wide grille mounting flanges on one end. Appropriate electrical **or** pneumatic actuators (**specifier select one**) shall be installed by the damper manufacturer in the factory and shall have been tested and classified under UL 555S with the damper at an elevated temperature of 250°F (121°C) or 350°F (177°C). Actuators shall incorporate an OEM internal spring return mechanism. External after-market spring mechanisms are not acceptable. Damper and actuator assembly shall be factory cycled a minimum of three times to ensure correct operation.

Each damper shall be equipped with a UL Classified heat responsive device that will cause the damper to close in a controlled manner and lock in a closed position by means of an over center/knee lock linkage, when the duct temperature reaches the maximum degradation temperature of the damper/actuator assembly as required by UL 555S. Closure devices that cause instantaneous closure are not acceptable. Damper manufacturer shall submit independent test data supporting low pressure drop design. Standard of acceptance: Nailor Industries Model 1221G.

G

COMBINATION FIRE/SMOKE DAMPERS