

- STANDARD FRAME
- FOR USE IN STATIC SYSTEMS
- 3 HOUR RATING
- UL 555 CLASSIFIED

MODELS:

- 0510 TYPE A
- 0520 TYPE B
- 0530 TYPE CR/CO
- 0530 TYPE CSR

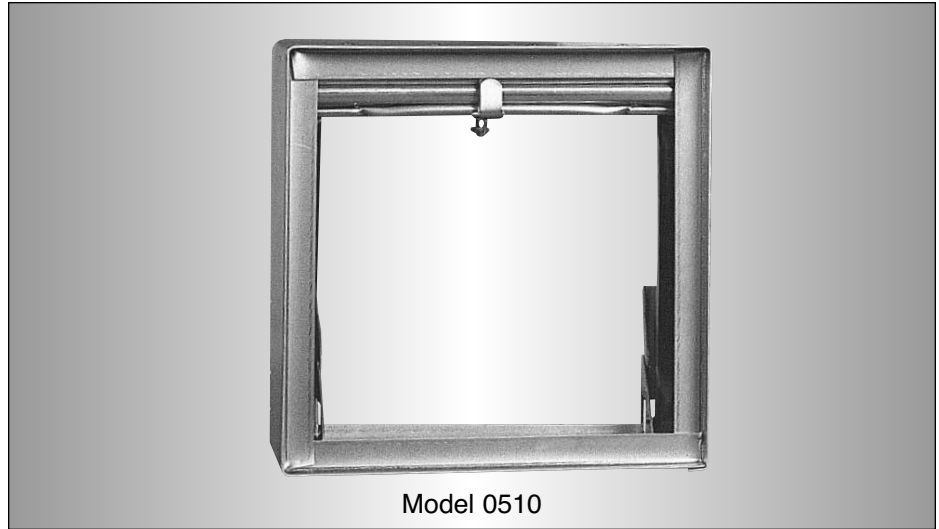

The Nailor 0500 Series standard frame curtain fire dampers, for use in static "fans off" systems where the HVAC system shuts down in the event of a fire, are UL/ULC approved to provide protection of HVAC ductwork penetrations in walls, partitions or floors that have a fire resistance rating of 4 hours or less. The 0500 Series features corrosion resistant steel frame and blades for performance that will last, and a choice of transition styles and factory installed sleeves to suit duct size, making installation fast and simple.

CURTAIN FIRE DAMPERS

CONSTRUCTION DETAILS:

	0510 (Type A)	0520 (Type B)	0530 (Type CR/CO)	0530 (Type CSR)
FRAME:	4 1/4" (108) wide, 22 ga. (0.85) roll-formed G60 galvanized steel	4 1/4" (108) wide, 22 ga. (0.85) roll-formed G60 galvanized steel	4 1/4" (108) wide, 22 ga. (0.85) roll-formed G60 galvanized steel; out of airstream	4 1/4" (108) wide, 22 ga. (0.85) roll-formed G60 galvanized steel; out of airstream
BLADES:	Curtain type, interlocking blades, 22 ga. (0.85) roll-formed G60 galvanized steel	Out of airstream. Curtain type, interlocking blades, 22 ga. (0.85) roll-formed G60 galvanized steel	Out of airstream. Curtain type, interlocking blades, 22 ga. (0.85) roll-formed G60 galvanized steel	Out of airstream. Curtain type, interlocking blades, 22 ga. (0.85) roll-formed G60 galvanized steel
ENCLOSURE:	N/A	Type B 22 ga. (.085) galvanized steel	Type C Round or Oval 22 ga. (.085) galvanized steel	Type C Square or Rect. 22 ga. (.085) galvanized steel
FUSIBLE LINK: (UL Listed)	165°F (74°C) Std. 212°F (100°C) available	165°F (74°C) Std. 212°F (100°C) available	165°F (74°C) Std. 212°F (100°C) available	165°F (74°C) Std. 212°F (100°C) available
BLADE CLOSURE:	Vertical mount; gravity Horizontal mount; stainless steel closure springs with galvanized steel locking ramps	Vertical mount; gravity Horizontal mount; stainless steel closure springs with galvanized steel locking ramps	Vertical mount; gravity Horizontal mount; stainless steel closure springs with galvanized steel locking ramps	Vertical mount; gravity Horizontal mount; stainless steel closure springs with galvanized steel locking ramps
MOUNTING:	Vertical or Horizontal	Vertical or Horizontal	Vertical or Horizontal	Vertical or Horizontal
AVAILABLE SLEEVE:	Galvanized steel; Specify SL Option	Galvanized steel; Specify SL Option	Galvanized steel; Specify SL Option	Galvanized steel; Specify SL Option

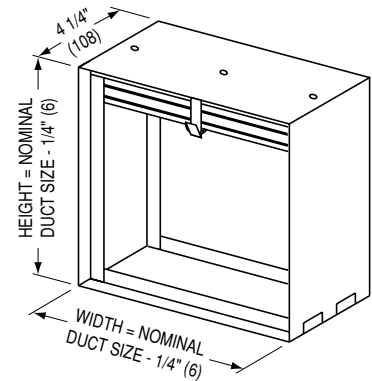

TYPE A: MODEL 0510

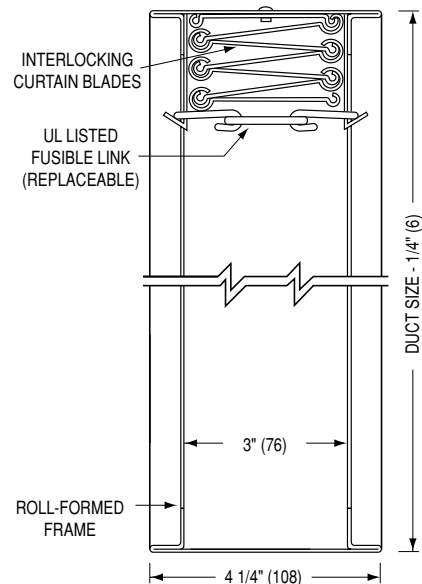

MODEL 0510V - VERTICAL MOUNT

For MIN./MAX. UL SIZES see chart on page D11.

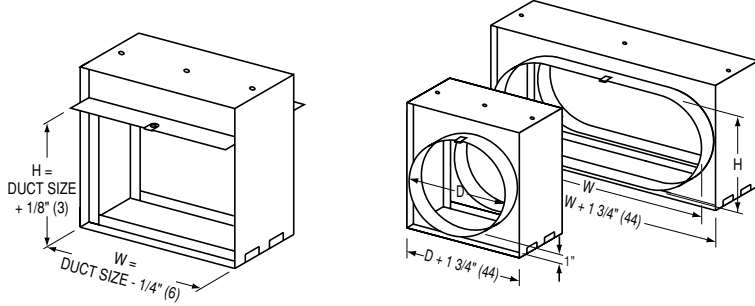

**TYPE B:
MODEL 0520**

**TYPE CR:
MODEL 0530**

**TYPE CO:
MODEL 0530**

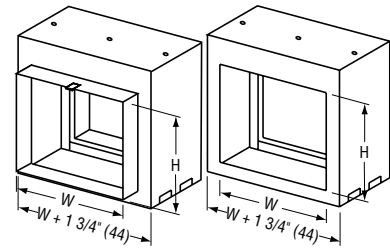

**TYPE CSR
WITH COLLAR
(STANDARD):
MODEL 0530**

**TYPE CSR
WITHOUT COLLAR:
MODEL 0530**

For overall damper dimensions see sizing chart on page D46.

PERFORMANCE DATA:

Curtain type fire dampers impose minimal resistance to air flow in the system. The following charts indicate both free area for the different damper types and static pressure losses for various velocities.

TYPE A DAMPER FREE AREA – sq. ft.

DUCT HEIGHT in inches (mm)	DUCT WIDTH in inches (mm)										
	6 (152)	12 (305)	18 (457)	24 (610)	30 (762)	36 (914)	42 (1067)	48 (1219)	54 (1372)	60 (1524)	
6 (152)	.14	.33	.52	.70	.89	1.1	1.3	1.5	1.7	1.8	
12 (305)	.31	.72	1.1	1.5	1.9	2.4	2.8	3.2	3.6	4.0	
18 (457)	.48	1.1	1.7	2.4	3.0	3.7	4.3	4.9	5.6	6.2	
24 (610)	.65	1.5	2.4	3.2	4.1	5.0	5.8	6.7	7.5	8.4	
30 (762)	.82	1.9	3.0	4.1	5.2	6.3	7.3	8.4	9.5	10.6	
36 (914)	.99	2.3	3.6	4.9	6.3	7.6	8.9	10.2	11.5	12.8	
42 (1067)	1.2	2.7	4.2	5.8	7.3	8.8	10.4	11.9	13.4	15.0	
48 (1219)	1.3	3.1	4.9	6.6	8.4	10.2	11.9	13.7	15.5	17.2	
54 (1372)	1.5	3.5	5.5	7.5	9.5	11.5	13.5	15.5	17.5	19.4	
60 (1524)	1.7	3.9	6.1	8.3	10.6	12.8	15.0	17.2	19.4	21.7	

TYPE B DAMPER FREE AREA – sq. ft.

DUCT HEIGHT in inches (mm)	DUCT WIDTH in inches (mm)										
	6 (152)	12 (305)	18 (457)	24 (610)	30 (762)	36 (914)	42 (1067)	48 (1219)	54 (1372)	60 (1524)	
6 (152)	.17	.39	.62	.84	1.1	1.3	1.5	1.7	2.0	2.2	
12 (305)	.36	.83	1.3	1.8	2.3	2.7	3.2	3.7	4.1	4.6	
18 (457)	.54	1.3	2.0	2.7	3.4	4.2	4.9	5.6	6.3	7.1	
24 (610)	.73	1.7	2.7	3.7	4.6	5.6	6.6	7.5	8.5	9.5	
30 (762)	.92	2.1	3.4	4.6	5.8	7.0	8.3	9.5	10.7	11.9	
36 (914)	1.1	2.6	4.1	5.5	7.0	8.5	9.9	11.4	12.9	14.4	
42 (1067)	1.3	3.0	4.7	6.5	8.2	9.9	11.6	13.4	15.1	16.8	
48 (1219)	1.5	3.5	5.4	7.4	9.4	11.4	13.3	15.3	17.3	19.2	
54 (1372)	1.7	3.9	6.1	8.3	10.6	12.8	15.0	17.2	19.5	21.7	

TYPE C DAMPERS HAVE FREE AREA EQUAL TO NOMINAL DUCT AREA.

To calculate Free Area of round duct:
 $DIAMETER^2 \times .00545 = \text{Free Area (sq ft.)}$

To determine pressure drop across open damper, calculate **free area velocity** as shown, find velocity on curve and read across for s.p. differential.

$$\text{Free Area Velocity (fpm)} = \frac{\text{cfm}}{\text{Free Area}}$$

Example:

1-36" x 24" Damper required for 8,500 cfm. (Type A)

$$FAV = \frac{8500}{5} = 1700 \text{ fpm}$$

1700 fpm located on the 'A' curve shows a pressure drop of .07 in. wg.

cfm = cubic feet per minute
 fpm = feet per minute velocity
 S.P. = static pressure in inches water gauge
 FAV = Free Area Velocity

Imperial System Shown
 To convert to SI (metric) system:

Multiply cfm by .4719 for liters per second
 fpm by .00508 for meters per second
 in. wg. by .2486 for kilopascals
 sq. ft. by .0929 for square meters

**FREE AREA VELOCITY
V.S. STATIC PRESSURE DROP**

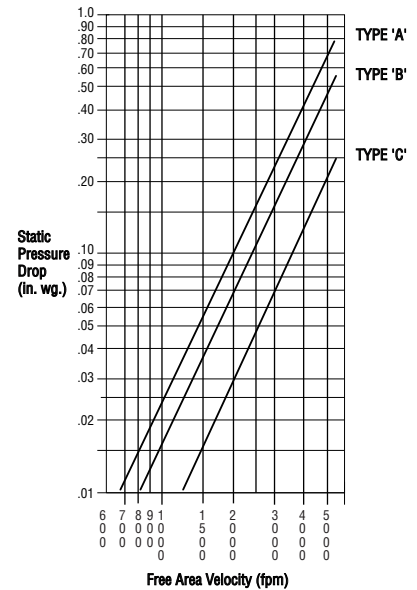

HOW TO SPECIFY

SUGGESTED SPECIFICATION:

Provide and install, as shown on plans and as described in specifications, 3 hour rated fire dampers as manufactured by Nailor Industries, meeting or exceeding the following criteria: Fire dampers shall be manufactured, tested and labeled in accordance with UL 555 Safety Standard for Fire Dampers - Sixth Edition, June 1999, and shall have a 3 hour fire resistance rating. Each fire damper shall bear a UL label verifying fire resistance rating in addition to intended mounting position. Fire dampers shall be suitably constructed for vertical or horizontal installation as required for each specific location.

Each fire damper shall be complete with a **(specifier select one)** 165°F (74°C) or 212°F (100°C) UL Listed fusible link. Fire dampers shall each include a steel sleeve of appropriate length/gauge and retaining angles, supplied by damper manufacturer to ensure proper installation in accordance with damper manufacturer's instructions. Contractor shall provide and install an access door at each fire damper, of appropriate size to allow for inspection, testing and fusible link replacement. Information submitted for approval shall include confirmation of UL qualifications, pressure drop data and manufacturer's installation instructions. Each shipment of fire dampers shall include same installation instructions. Fire dampers shall be Nailor Industries Models 0510 (Type A), 0520 (Type B), 0530 (Type C).