

- THINLINE FRAME
- FOR USE IN STATIC SYSTEMS
- 1 1/2 HOUR RATING
- UL 555 CLASSIFIED

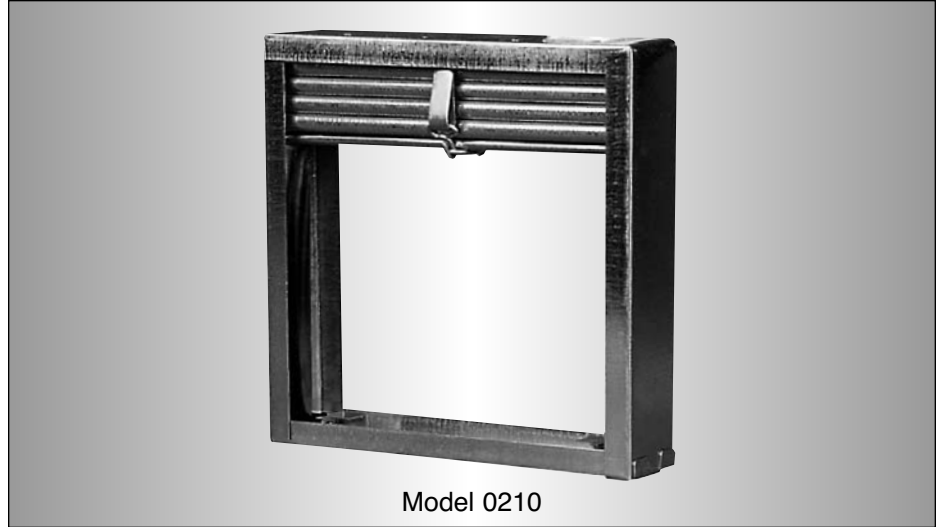

**MODELS:**

- |      |            |
|------|------------|
| 0210 | TYPE A     |
| 0220 | TYPE B     |
| 0230 | TYPE CR/CO |
| 0240 | TYPE CSR   |

**D**

**CURTAIN FIRE DAMPERS**

The Nailor 0200 Series Thinline curtain fire dampers are UL/ULC approved for use where building codes require the protection of HVAC ductwork penetrations in walls, partitions or floors that have a fire resistance rating of 2 hours or less. The 0200 Series is classified for use only in static "fans off" systems where the HVAC system is automatically shut down in the event of a fire alarm. The 0200 Series Thinline dampers are only 2" (51) deep making them ideal for installation in narrow fire rated partitions, transfer duct openings, behind grilles or in any other application where space is limited. The 0200 Series feature corrosion resistant steel frame and blades for lasting performance, and choice of transition styles and factory installed sleeves to suit duct size, making installation fast and simple.

**CONSTRUCTION DETAILS:**

	0210 (Type A)	0220 (Type B)	0230 (Type CR/CO)	0240 (Type CSR)
<b>FRAME:</b>	2" (51) wide, 22 ga. (0.85) roll-formed G60 galvanized steel	2" (51) wide, 22 ga. (0.85) roll-formed G60 galvanized steel	2" (51) wide, 22 ga. (0.85) roll-formed G60 galvanized steel; out of airstream	2" (51) wide, 22 ga. (0.85) roll-formed G60 galvanized steel; out of airstream
<b>BLADES:</b>	Curtain type, interlocking blades, 22 ga. (0.85) roll-formed G60 galvanized steel	Out of airstream. Curtain type, interlocking blades, 22 ga. (0.85) roll-formed G60 galvanized steel	Out of airstream. Curtain type, interlocking blades, 22 ga. (0.85) roll-formed G60 galvanized steel	Out of airstream. Curtain type, interlocking blades, 22 ga. (0.85) roll-formed G60 galvanized steel
<b>ENCLOSURE:</b>	N/A	Type B 22 ga. (.085) galvanized steel	Type C Round or Oval 22 ga. (.085) galvanized steel	Type C Square or Rect. 22 ga. (.085) galvanized steel
<b>FUSIBLE LINK: (UL Listed)</b>	165°F (74°C) Std. 212°F (100°C) available	165°F (74°C) Std. 212°F (100°C) available	165°F (74°C) Std. 212°F (100°C) available	165°F (74°C) Std. 212°F (100°C) available
<b>BLADE CLOSURE:</b>	Vertical mount; gravity Horizontal mount; stainless steel closure springs with galvanized steel locking ramps	Vertical mount; gravity Horizontal mount; stainless steel closure springs with galvanized steel locking ramps	Vertical mount; gravity Horizontal mount; stainless steel closure springs with galvanized steel locking ramps	Vertical mount; gravity Horizontal mount; stainless steel closure springs with galvanized steel locking ramps
<b>MOUNTING:</b>	Vertical or Horizontal	Vertical or Horizontal	Vertical or Horizontal	Vertical or Horizontal
<b>AVAILABLE SLEEVE:</b>	Galvanized steel; Specify SL Option	Galvanized steel; Specify SL Option	Galvanized steel; Specify SL Option	Galvanized steel; Specify SL Option

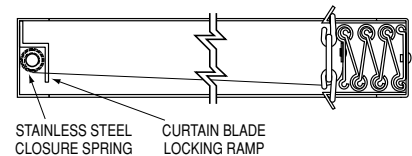
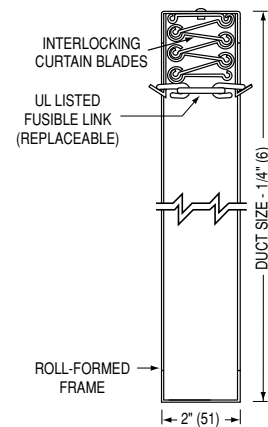
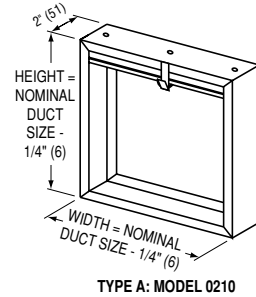

For MIN./MAX. UL SIZES see chart on page D10.

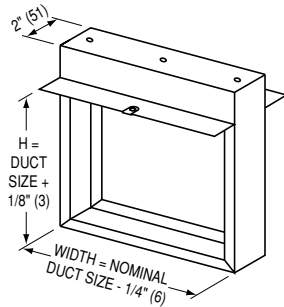

**TYPE B:  
MODEL 0220**

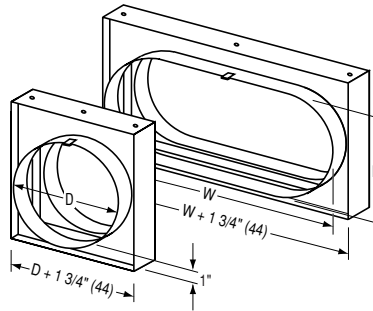

**TYPE CR:  
MODEL 0230**

**TYPE CO:  
MODEL 0230**

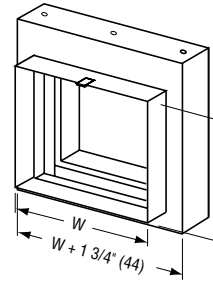

**TYPE CSR  
WITH COLLAR  
(STANDARD):  
MODEL 0240**

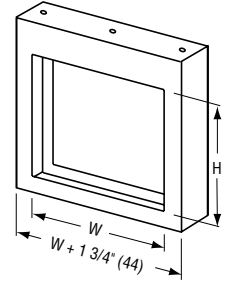

**TYPE CSR  
WITHOUT COLLAR:  
MODEL 0240**

For overall damper dimensions, see sizing chart on page D47.

## PERFORMANCE DATA:

Curtain type fire dampers impose minimal resistance to air flow in the system. The following charts indicate both free area for the different damper types and static pressure losses for various velocities.

**TYPE A THINLINE DAMPER FREE AREA – sq. ft.**

DUCT HEIGHT in inches (mm)	DUCT WIDTH in inches (mm)							
	6 (152)	12 (305)	18 (457)	24 (610)	30 (762)	36 (914)	40 (1016)	
6 (152)	.12	.27	.44	.59	.75	.94	1.02	
12 (305)	.27	.61	.93	1.36	1.7	2.1	2.4	
18 (457)	.42	.94	1.5	2.2	2.7	3.4	3.7	
24 (610)	.55	1.29	2.1	3.0	3.7	4.5	4.9	
30 (762)	.71	1.65	2.6	3.8	4.3	5.7	6.3	
36 (914)	.86	2.1	3.2	4.6	5.7	7.0	7.7	
40 (1067)	.93	2.3	3.5	5.1	6.3	7.6	8.8	
48 (1219)	1.14	2.7	4.3	6.0	7.7	9.4		
54 (1372)	1.32	3.1	4.9	6.9	8.8	10.7		
60 (1524)	1.51	3.5	5.5	7.7	9.9	11.8		

**TYPE B THINLINE DAMPER FREE AREA – sq. ft.**

DUCT HEIGHT in inches (mm)	DUCT WIDTH in inches (mm)							
	6 (152)	12 (305)	18 (457)	24 (610)	30 (762)	36 (914)	40 (1016)	
6 (152)	.15	.32	.52	.69	.88	1.09	1.17	
12 (305)	.31	.70	1.07	1.55	1.95	2.4	2.7	
18 (457)	.47	1.05	1.7	2.5	3.05	3.8	4.2	
24 (610)	.62	1.44	2.3	3.4	4.2	5.1	5.6	
30 (762)	.80	1.84	2.9	4.3	4.9	6.5	7.2	
36 (914)	.95	2.33	3.6	5.1	6.4	7.8		
40 (1067)	1.0	2.5	3.8	5.6	7.0	8.5		
48 (1219)	1.3	3.1	4.8	6.8	8.6	10.4		

TYPE C DAMPERS HAVE FREE AREA EQUAL TO NOMINAL DUCT AREA.

To calculate Free Area of round duct:  
DIAMETER<sup>2</sup> x .00545 = Free Area (sq ft.)

To determine pressure drop across open damper, calculate **free area velocity** as shown, find velocity on curve and read across for s.p. differential.

$$\text{Free Area Velocity (fpm)} = \frac{\text{cfm}}{\text{Free Area}}$$

Example:  
1-36" x 36" Damper required for 14,000 cfm. (Type A)  
FAV =  $\frac{14,000}{7 \text{ sq. ft.}}$  = 2000 fpm

2000 fpm located on the 'A' curve shows a pressure drop of .12 in. wg.  
cfm = cubic feet per minute  
fpm = feet per minute velocity  
S.P. = static pressure in inches water gauge  
FAV = Free Area Velocity

Imperial System Shown  
To convert to SI (metric) system:

Multiply cfm by .4719 for liters per second  
fpm by .00508 for meters per second  
in. wg. by .2486 for kilopascals  
sq. ft. by .0929 for square meters

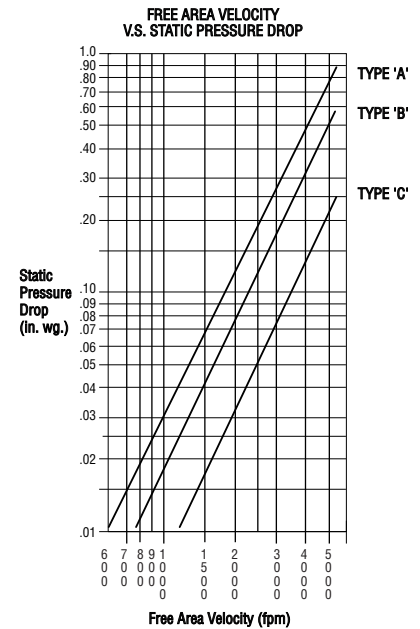

## HOW TO SPECIFY

### SUGGESTED SPECIFICATION:

Provide and install, as shown on plans and as described in specifications, Thinline fire dampers as manufactured by Nailor Industries, meeting or exceeding the following criteria: Fire dampers shall be manufactured, tested and labeled in accordance with UL 555 Safety Standard for Fire Dampers - Sixth Edition, June 1999, and shall have 1 1/2 hour fire resistance rating. Each fire damper shall bear a UL label verifying fire resistance rating in addition to intended mounting position. Fire dampers shall be suitably constructed for vertical or horizontal installation as required for each specific location.

Thinline style fire damper frame shall be a maximum of 2" (51) in width, roll-formed from G60 galvanized steel. Blades shall be Thinline type, roll-formed G60 galvanized steel. Each fire damper shall be complete with a (**specifier select one**) 165°F (74°C) or 212°F (100°C) UL Listed fusible link. Fire dampers shall each include a steel sleeve of appropriate length/gauge and retaining angles, supplied by damper manufacturer to ensure proper installation in accordance with damper manufacturer's instructions. Contractor shall provide and install an access door at locations where the fire damper cannot be accessed through grille or duct end opening, to allow for inspection, testing and fusible link replacement. Information submitted for approval shall include confirmation of UL qualifications, pressure drop data and manufacturer's installation instructions. Each shipment of fire dampers shall include same installation instructions. Thinline fire dampers shall be Nailor Industries Models 0210 (Type A), 0220 (Type B), 0230 (Type C).