

- STANDARD FRAME
- FOR USE IN STATIC SYSTEMS
- 1 1/2 HOUR RATING
- UL 555 CLASSIFIED

MODELS:

0110/0114

0120/0124

0130/0134

0140

TYPE A

TYPE B

TYPE CR/CO

TYPE CSR

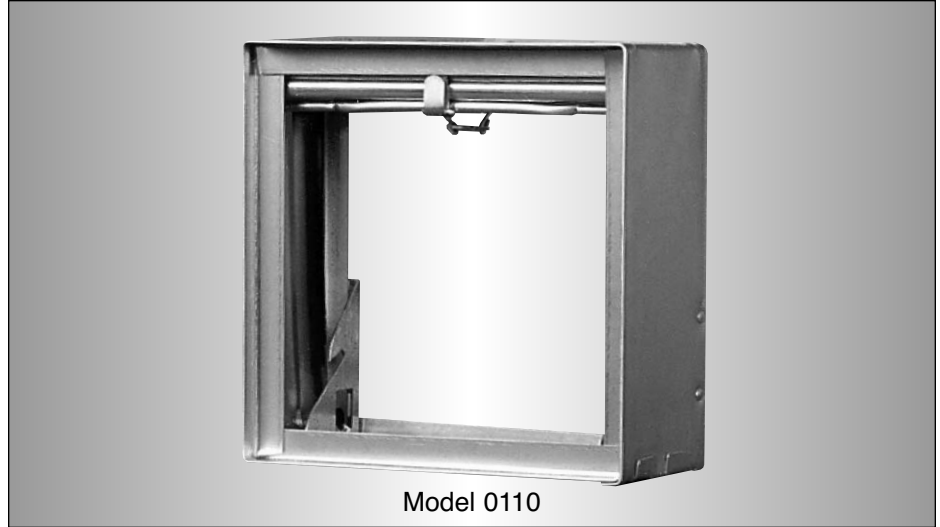

The Nailor 0100 Series curtain fire dampers, for use in static "fans off" systems where the HVAC system shuts down in the event of a fire, are UL/ULC approved to provide protection of HVAC ductwork penetrations in walls, partitions or floors that have a fire resistance rating of 2 hours or less. The 0100 Series features corrosion resistant steel frame and blades for performance that lasts, and a choice of transition styles and factory installed sleeves to suit duct size, making installation fast and simple.

D

CURTAIN FIRE DAMPERS

CONSTRUCTION DETAILS:

	0110 (Type A)	0120 (Type B)	0130 (Type CR/CO)	0140 (Type CSR)
FRAME:	4 1/4" (108) wide, 22 ga. (0.85) roll-formed G60 galvanized steel	4 1/4" (108) wide, 22 ga. (0.85) roll-formed G60 galvanized steel	4 1/4" (108) wide, 22 ga. (0.85) roll-formed G60 galvanized steel; out of airstream	4 1/4" (108) wide, 22 ga. (0.85) roll-formed G60 galvanized steel; out of airstream
BLADES:	Curtain type, interlocking blades, 22 ga. (0.85) roll-formed G60 galvanized steel	Out of airstream. Curtain type, interlocking blades, 22 ga. (0.85) roll-formed G60 galvanized steel	Out of airstream. Curtain type, interlocking blades, 22 ga. (0.85) roll-formed G60 galvanized steel	Out of airstream. Curtain type, interlocking blades, 22 ga. (0.85) roll-formed G60 galvanized steel
ENCLOSURE:	N/A	Type B 22 ga. (.085) galvanized steel	Type C Round or Oval 22 ga. (.085) galvanized steel	Type C Square or Rect. 22 ga. (.085) galvanized steel
FUSIBLE LINK: (UL Listed)	165°F (74°C) Std. 212°F (100°C) available	165°F (74°C) Std. 212°F (100°C) available	165°F (74°C) Std. 212°F (100°C) available	165°F (74°C) Std. 212°F (100°C) available
BLADE CLOSURE:	Vertical mount; gravity Horizontal mount; stainless steel closure springs with galvanized steel locking ramps	Vertical mount; gravity Horizontal mount; stainless steel closure springs with galvanized steel locking ramps	Vertical mount; gravity Horizontal mount; stainless steel closure springs with galvanized steel locking ramps	Vertical mount; gravity Horizontal mount; stainless steel closure springs with galvanized steel locking ramps
MOUNTING:	Vertical or Horizontal	Vertical or Horizontal	Vertical or Horizontal	Vertical or Horizontal
INTEGRAL SLEEVE:	See Model	See Model	See Model	Specify SL Option
	22 ga (.085) x12" (305) long	0114-12	0124-12	
	22 ga (.085) x14" (356) long	0114-14	0124-14	
	22 ga (.085) x16" (406) long	0114-16	0124-16	
			0134-12	
			0134-14	
			0134-16	

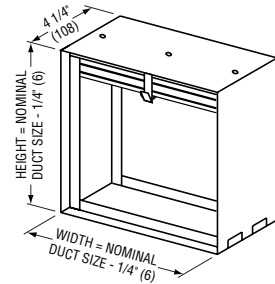

TYPE A: MODEL 0110

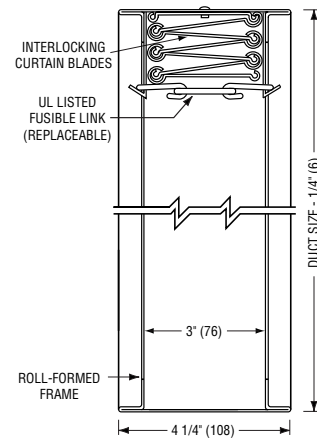

MODEL 0110V – VERTICAL MOUNT

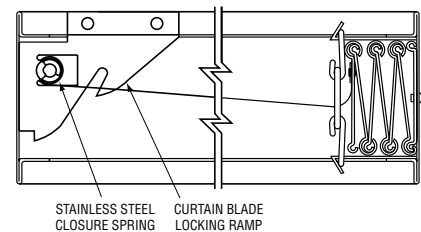

MODEL 0110H – HORIZONTAL MOUNT

For MIN./MAX. UL SIZES see chart on page D10.

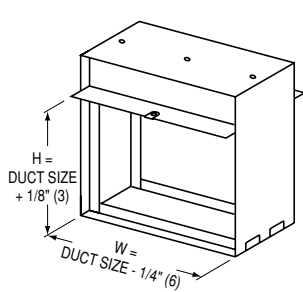

**TYPE B:
MODEL 0120**

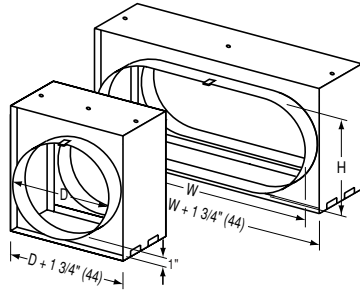

**TYPE CR:
MODEL 0130**

**TYPE CO:
MODEL 0130**

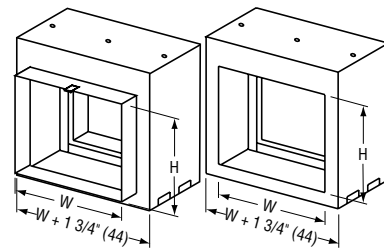

**TYPE CSR
WITH COLLAR
(STANDARD):
MODEL 0140**

**TYPE CSR
WITHOUT COLLAR:
MODEL 0140**

For overall damper dimensions see sizing chart on page D46.

PERFORMANCE DATA:

Curtain type fire dampers impose minimal resistance to air flow in the system. The following charts indicate both free area for the different damper types and static pressure losses for various velocities.

TYPE A DAMPER FREE AREA – sq. ft.

DUCT HEIGHT in inches (mm)	DUCT WIDTH in inches (mm)									
	6 (152)	12 (305)	18 (457)	24 (610)	30 (762)	36 (914)	42 (1067)	48 (1219)	54 (1372)	60 (1524)
6 (152)	.14	.33	.52	.70	.89	1.1	1.3	1.5	1.7	1.8
12 (305)	.31	.72	1.1	1.5	1.9	2.4	2.8	3.2	3.6	4.0
18 (457)	.48	1.1	1.7	2.4	3.0	3.7	4.3	4.9	5.6	6.2
24 (610)	.65	1.5	2.4	3.2	4.1	5.0	5.8	6.7	7.5	8.4
30 (762)	.82	1.9	3.0	4.1	5.2	6.3	7.3	8.4	9.5	10.6
36 (914)	.99	2.3	3.6	4.9	6.3	7.6	8.9	10.2	11.5	12.8
42 (1067)	1.2	2.7	4.2	5.8	7.3	8.8	10.4	11.9	13.4	15.0
48 (1219)	1.3	3.1	4.9	6.6	8.4	10.2	11.9	13.7	15.5	17.2
54 (1372)	1.5	3.5	5.5	7.5	9.5	11.5	13.5	15.5	17.5	19.4
60 (1524)	1.7	3.9	6.1	8.3	10.6	12.8	15.0	17.2	19.4	21.7

TYPE B DAMPER FREE AREA – sq. ft.

DUCT HEIGHT in inches (mm)	DUCT WIDTH in inches (mm)									
	6 (152)	12 (305)	18 (457)	24 (610)	30 (762)	36 (914)	42 (1067)	48 (1219)	54 (1372)	60 (1524)
6 (152)	.17	.39	.62	.84	1.1	1.3	1.5	1.7	2.0	2.2
12 (305)	.36	.83	1.3	1.8	2.3	2.7	3.2	3.7	4.1	4.6
18 (457)	.54	1.3	2.0	2.7	3.4	4.2	4.9	5.6	6.3	7.1
24 (610)	.73	1.7	2.7	3.7	4.6	5.6	6.6	7.5	8.5	9.5
30 (762)	.92	2.1	3.4	4.6	5.8	7.0	8.3	9.5	10.7	11.9
36 (914)	1.1	2.6	4.1	5.5	7.0	8.5	9.9	11.4	12.9	14.4
42 (1067)	1.3	3.0	4.7	6.5	8.2	9.9	11.6	13.4	15.1	16.8
48 (1219)	1.5	3.5	5.4	7.4	9.4	11.4	13.3	15.3	17.3	19.2
54 (1372)	1.7	3.9	6.1	8.3	10.6	12.8	15.0	17.2	19.5	21.7

TYPE C DAMPERS HAVE FREE AREA EQUAL TO NOMINAL DUCT AREA.

To calculate Free Area of round duct:
DIAMETER² x .00545 = Free Area (sq ft.)

To determine pressure drop across open damper, calculate **free area velocity** as shown, find velocity on curve and read across for s.p. differential.

$$\text{Free Area Velocity (fpm)} = \frac{\text{cfm}}{\text{Free Area}}$$

Example:
1-36" x 24" Damper required for 8,500 cfm. (Type A)
FAV = $\frac{8500}{5 \text{ sq. ft.}} = 1700 \text{ fpm}$

1700 fpm located on the 'A' curve shows a pressure drop of .07 in. wg.

cfm = cubic feet per minute
fpm = feet per minute velocity
S.P. = static pressure in inches water gauge
FAV = Free Area Velocity

Imperial System Shown
To convert to SI (metric) system:

Multiply cfm by .4719 for liters per second
fpm by .00508 for meters per second
in. wg. by .2486 for kilopascals
sq. ft. by .0929 for square meters

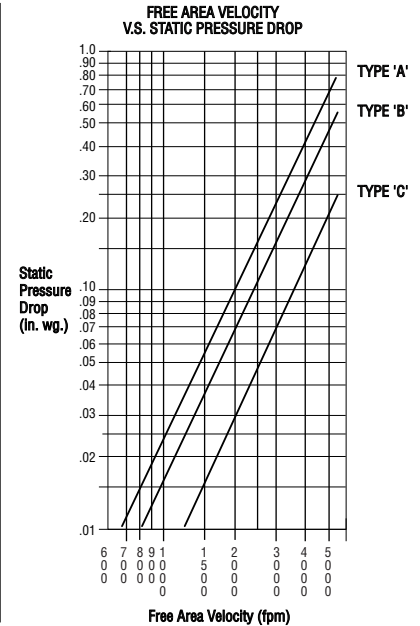

HOW TO SPECIFY

SUGGESTED SPECIFICATION:

Provide and install, as shown on plans and as described in specifications, fire dampers as manufactured by Nailor Industries, meeting or exceeding the following criteria: Fire dampers shall be manufactured, tested and labeled in accordance with UL 555 Safety Standard for Fire Dampers - Sixth Edition, June 1999, and shall have 1 1/2 hour fire resistance rating. Each fire damper shall bear a UL label verifying fire resistance rating in addition to intended mounting position. Fire dampers shall be suitably constructed for vertical or horizontal installation as required for each specific location.

Each fire damper shall be complete with a **(specifier select one)** 165°F (74°C) or 212°F (100°C) UL Listed fusible link. Fire dampers shall each include a steel sleeve of appropriate length/gauge and retaining angles, supplied by damper manufacturer to ensure proper installation in accordance with damper manufacturer's instructions. Contractor shall provide and install an access door at each fire damper, of appropriate size to allow for inspection, testing and fusible link replacement. Information submitted for approval shall include confirmation of UL qualifications, pressure drop data and manufacturer's installation instructions. Each shipment of fire dampers shall include same installation instructions. Fire dampers shall be Nailor Industries Models 0110 (Type A), 0120 (Type B), 0130 (Type C).

INTEGRAL SLEEVE STATIC FIRE DAMPERS (1 1/2 HOUR LISTING)

FOR USE IN STATIC SYSTEMS.

Nailor integral sleeve fire dampers ensure proper damper mounting in sleeve and can be shipped direct to job site for immediate installation, eliminating costly and inconvenient shop handling. All units are constructed with 22 ga. (0.85) roll-formed G60 galvanized steel integral sleeve available in 12" (305), 14" (356) or 16" (406) length. Optional 'Quick-Set' retaining angles are available to complete the installation package.

TYPE A: MODEL 0114 - 12/14/16

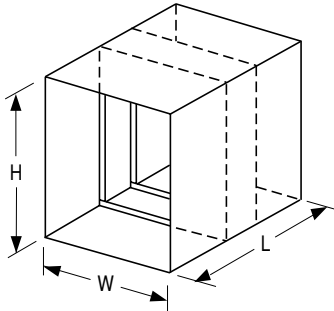

Type 'A' – Blades and frame in the airstream.

Models: 0114V Vertical and 0114H Horizontal

Min. size - Vertical or Horizontal 4" x 4" (102 x 102)

Max. size - Vertical or Horizontal 48" x 48" (1219 x 1219)

TYPE B: MODEL 0124 - 12/14/16

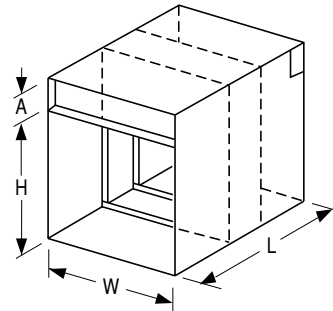

Type 'B' – Blades out of airstream.

Models: 0124V Vertical and 0124H Horizontal

Min. size - Vertical 4" x 3" (102 x 76)

Horizontal 4" x 4" (102 x 102)

Max. size - Vertical or Horizontal 48" x 43" (1219 x 1092)

Damper Height (H)	Dim. 'A'
5" thru 17" (127 thru 432)	2" (51)
18" thru 27" (457 thru 686)	3" (76)
28" thru 36" (711 thru 914)	4" (102)
37" thru 43" (940 thru 1092)	5" (127)

CONSTRUCTION DETAILS:

INTEGRAL

SLEEVE/FRAME: 22 ga. (0.85) roll-formed G60 galvanized steel.
 01 x 4 x -12 Length 12" (305)
 01 x 4 x -14 Length 14" (356)
 01 x 4 x -16 Length 16" (406)

BLADES: Curtain type interlocking blades, 22 ga. (0.85) roll-formed G60 galvanized steel.

FUSIBLE LINK: 165°F (74°C) standard. UL Listed.
 212°F (100°C) available.

BLADE CLOSURE: Vertical mount model; gravity.
 Horizontal mount models are equipped with stainless steel closure springs and galvanized steel locking ramps.

TYPE C: MODEL 0134 - 12/14/16

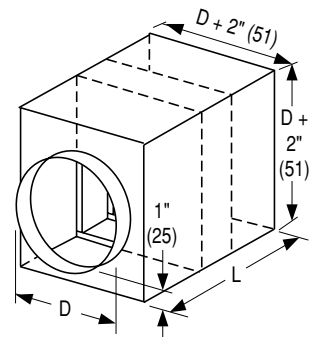

Type 'CR' – Round transition collars.

Blades partially in airstream.

Models: 0134V Vertical and 0134H Horizontal

Min. size - Vertical 3" dia. (76)

Horizontal 4" dia. (102)

Max. size - Vertical or Horizontal 42" dia. (1067)

D

CURTAIN FIRE DAMPERS

HOW TO SPECIFY

INTEGRAL SLEEVE STATIC FIRE DAMPERS

MODELS: 0114 - 12/14/16
0124 - 12/14/16
0134 - 12/14/16

SUGGESTED SPECIFICATION:

Provide and install, as shown on plans and as described in specifications, integral sleeve fire dampers as manufactured by Nailor Industries, meeting or exceeding the following criteria: Fire dampers shall be manufactured, tested and labeled in accordance with UL 555 Safety Standard for Fire Dampers - Sixth Edition, June 1999, and shall have a 1 1/2 hour fire resistance rating. Each fire damper shall bear a UL label verifying fire resistance rating in addition to intended mounting position. Fire dampers shall be suitably constructed for vertical or horizontal installation as required for each specific location. Each fire damper shall be complete with a **(specifier select one)** 165°F (74°C) **or** 212°F (100°C) UL Listed fusible link. In addition, each fire damper shall be provided from the factory in an integral 22 ga. (0.85) galvanized steel sleeve of **(specifier select one)** 12" (305), 14" (356) **or** 16" (406) in length complete with Nailor 'Quick-Set' retaining angles, to ensure proper installation in accordance with damper manufacturer's instructions. Contractor shall provide and install an access door at each fire damper, of appropriate size to allow for inspection, testing and fusible link replacement. Information submitted for approval shall include confirmation of UL qualifications, pressure drop data, and manufacturer's installation instructions. Each shipment of fire dampers shall include same installation instructions. Integral sleeve fire dampers shall be Nailor Industries Models 0114-12 **or** 14 **or** 16 (Type A), 0124-12 **or** 14 **or** 16 (Type B), 0134-12 **or** 14 **or** 16 (Type C).