

- EXTRUDED ALUMINUM AIRFOIL BLADE AND FRAME
- ULTRA-LOW LEAKAGE
- HIGH PERFORMANCE

MODELS:

2010EAF PARALLEL BLADE

2020EAF OPPOSED BLADE



Model 2020EAF

Models 2010EAF/2020EAF are Nailor's extruded aluminum airfoil blade and frame premium damper, ideal for use in high velocity, medium pressure, commercial and industrial HVAC systems. They offer unsurpassed leakage and pressure drop characteristics for superior performance that meets the IEC Code maximum leakage for building envelope dampers criteria of 3 cfm/ft.² (15.2 L/s/m²). Model 2020EAF opposed blade, is AMCA licensed, and provides the ultimate in ultra-low leakage performance characteristics. Features include a heavy duty extruded aluminum hat channel frame, no-maintenance concealed linkage, and rugged extruded aluminum airfoil blades that combine superior rigidity and deflection resistance with low pressure drop. Unique design compression type seals are keyed and locked into blade extrusion, providing the ultimate in ultra-low leakage and high performance.

B

CONTROL DAMPERS

STANDARD CONSTRUCTION:

- FRAME:** 5" x 7/8" x 0.125" (127 x 22 x 3.2)
Type 6063-T5 extruded aluminum frame.
- BLADES:** Airfoil type 6063-T5 extruded aluminum on 5 1/2" (140) centers.
- LINKAGE:** Concealed side type totally enclosed within the frame and out of the air stream. Plated steel.
- BEARINGS:** 1/2" (13) dia. Oilite[®] self-lubricating bronze.
- AXLES:** 1/2" (13) dia. plated steel double bolted to blades.
- DRIVE SHAFT:** 6" (152) long x 1/2" (13) dia. rigid drive shaft; or optional lock-on shaft with outboard support bracket (standard in Canada), on all single section dampers. A 1/2" (13) or 1" (25) dia. factory installed jackshaft is standard on all multiple section dampers.
- BLADE SEALS:** Silicone. Mechanically locked in place.
- JAMB SEALS:** Cambered stainless steel.
- MINIMUM SIZE:** Single blade (parallel) 8" x 8" (203 x 203). Two blades (parallel or opposed) 8" x 12" (203 x 305).
- MAXIMUM SIZE:** Single section size is 60" x 72" (1524 x 1829). Multiple section - unlimited.

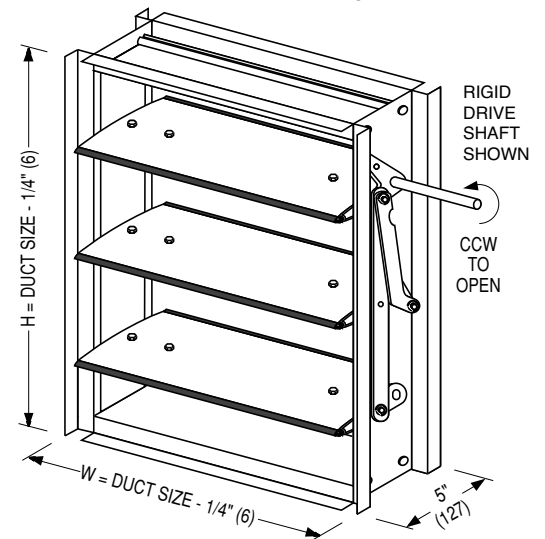

MODEL 2010EAF
PARALLEL BLADE

MODEL 2020EAF
OPPOSED BLADE

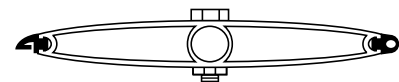
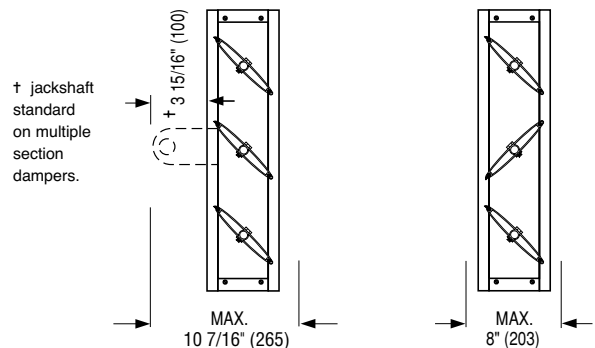

EXTRUDED ALUMINUM AIRFOIL BLADE

MODELS: 2010EAF/2020EAF PERFORMANCE DATA:

PERFORMANCE LIMITATIONS:

DAMPER WIDTH		MAXIMUM SYSTEM PRESSURE	MAXIMUM SYSTEM VELOCITY
IN.	MM		
60	1524	5.0" w.g.	3000 FPM
48	1219	8.0" w.g.	4000 FPM
36	914	10.0" w.g.	4500 FPM
24	610	12.0" w.g.	5000 FPM
12	305	14.0" w.g.	6000 FPM

The 2000 Series with its standard maximum single section and multiple section sizing limitation may be used in applications with system pressures of up to 5.0" w.g.. The 2000 Series may also be used in systems with higher total pressures by reducing the damper section width as shown in the table.

Temperature Range: -50°F to 250°F (-45°C to 157°C)



Nailor Industries Inc. certifies that the Model 2020EAF Damper shown herein is licensed to bear the AMCA seal. The ratings shown are based on tests and procedures performed in accordance with AMCA Publication 511 and comply with the requirements of the AMCA Certified Ratings Program. The AMCA Certified Ratings Seal applies to air leakage ratings and air performance ratings. Model 2010EAF is not licensed to bear the AMCA seal.

LEAKAGE CLASS:

DAMPER WIDTH	@ 1" w.g. (0.25 kPa)	@ 4" w.g. (1.0 kPa)	@ 8" w.g. (2.0 kPa)	@ 12" w.g. (3.0 kPa)
12" (305)	1A	1A	1A	1A
24" (305)	1A	1A	1A	1A
36" (305)	1A	1A	1A	—
48" (305)	1A	1A	—	—
60" (305)	1A	1A	—	—

Maximum leakage permitted for Class rating is as follows:

Class 1A: 3 cfm/sq. ft. @ 1" w.g. (15.2 l/s/m² @ 0.25 kPa)

8 cfm/sq. ft. @ 4" w.g. (40.6 l/s/m² @ 1.0 kPa)

11 cfm/sq. ft. @ 8" w.g. (55.9 l/s/m² @ 2.0 kPa)

14 cfm/sq. ft. @ 12" w.g. (71.1 l/s/m² @ 3.0 kPa)

Leakage tested in accordance with AMCA Standard 500-D-98. Data based on a torque of 8" lbs./sq. ft. (minimum 20" lbs.) applied to hold the damper in closed position. Leakage class is based on operation between 50°F and 104°F (10°C and 40°C). Data corrected to standard air density of 0.075 lbs./ft.³

PRESSURE DROP:

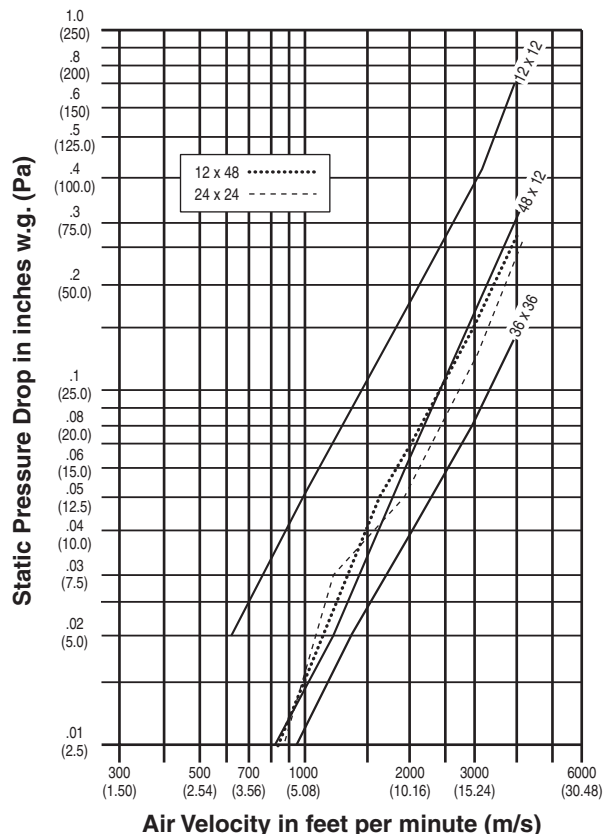

Pressure drop tested per AMCA Standard 500-D-98, Figure 5.3. Data corrected to standard air density of 0.075 lbs./ft.³.

Size: 12 x 12 (305 x 305)

VELOCITY fpm (m/s)	PRESSURE DROP in. w.g. (Pa)
492 (2.50)	.01 (2)
992 (5.04)	.04 (10)
2056 (10.44)	.17 (42)
2994 (15.21)	.35 (87)
3922 (19.93)	.61 (151)

Size: 24 x 24 (610 x 610)

VELOCITY fpm (m/s)	PRESSURE DROP in. w.g. (Pa)
891 (4.53)	.01 (2)
1244 (6.32)	.02 (5)
1942 (9.87)	.04 (10)
3074 (15.62)	.10 (25)
4344 (22.07)	.20 (50)

Size: 36 x 36 (914 x 914)

VELOCITY fpm (m/s)	PRESSURE DROP in. w.g. (Pa)
513 (2.61)	.01 (2)
1087 (5.52)	.01 (2)
1959 (9.95)	.03 (7)
2974 (15.11)	.06 (15)
3922 (19.93)	.12 (30)

Size: 48 x 12 (1219 x 305)

VELOCITY fpm (m/s)	PRESSURE DROP in. w.g. (Pa)
881 (4.48)	.01 (2)
1249 (6.35)	.02 (5)
1950 (9.91)	.04 (10)
3086 (15.68)	.13 (32)
4361 (22.15)	.26 (65)

Size: 12 x 48 (305 x 1219)

VELOCITY fpm (m/s)	PRESSURE DROP in. w.g. (Pa)
869 (4.42)	.01 (2)
1663 (8.45)	.05 (12)
2027 (10.30)	.07 (17)
2935 (14.91)	.15 (37)
4008 (20.36)	.27 (67)

MODELS: 2010EAF/2020EAF

AVAILABLE OPTIONS/ACCESSORIES:

The following construction options and accessories are available on Models 2010EAF /2020EAF. See page B55 for detailed description of options/accessories.

	CODE	DESCRIPTION
BLADE LINKAGE:	SSL SSA	Stainless Steel Linkage Stainless Steel Axles Only
BEARINGS:	BS BT	Stainless Steel Bearings Thrust Bearings
ROUND/OVAL TRANSITION:	CR CO	Transition Casing for Round Duct Transition Casing for Oval Duct
OPERATOR ACCESSORIES:	HLQ PCE PCI FMO FMI JK5 JK1 VCK	Hand Locking Quadrant External Chain Operator Internal Chain Operator Factory Mounted Actuator-Outside w/ side plate Factory Mounted Actuator-Internal w/ jackshaft 1/2" (13) Dia. Jackshafting for Single Section 1" (25) Dia. Jackshafting for Single Section Vertical Interconnection Kit

B

CONTROL DAMPERS

At Nailor Industries, we take pride in our flexibility to meet the needs of your specific applications. The options listed above provide a variety of commonly used modifications to satisfy the majority of today's diverse requirements. Should your application require a more unique configuration, please consult your authorized Nailor Representative or the Nailor Industries office nearest you for assistance.

HOW TO SPECIFY OR TO ORDER

MODELS: 2010EAF/2020EAF

HOW TO ORDER:

Standard construction is shown in highlighted box. Option codes are listed below. See previous page for description of options.

	MODEL	SIZE (W X H)	FRAME MATERIAL	DRIVE LOCATION	OPTIONAL BLADE LINKAGE	BEARINGS	ROUND/OVAL TRANSITION OPERATOR ACCESSORIES
2010	ie: 48 x 24	EAF	DR/DL	–	BO	–	–
2020		↑		SSL SSA	BS BT	CR CO	HLQ FMO FMI PCE PCI JK5 JK1 VCK

- Notes:
- ↑ Arrow indicates 'must select' option.
 - Right hand driveshaft is standard. For left hand driveshaft simply rotate the damper so that the driveshaft is on left hand side, as blade and jamb seals are designed to work with airflow in either direction. 1/2" (13) or 1" (25) dia. jackshaftering is standard on all multiple section wide units.
 - If Pull Chain Operator option is selected, please specify length of chain required.
 - If Option CR Round Transition casing (or CO) is selected please order by duct size diameter ie: 36"ø.

SUGGESTED SPECIFICATION:

Provide and install, as shown on plans and/or schedules, ultra low-leakage dampers meeting or exceeding the following criteria: Frame shall be constructed of type 6063-T5 extruded aluminum hat channel design of minimum 0.125" (3.2) thickness. Blades shall be of type 6063-T5 extruded aluminum airfoil design on maximum 6" (152) centers with integral structural reinforcing tube running full length of each blade. Blade axles shall be 1/2" (13) dia. plated steel, double thru-bolted to blade at each end to provide positive locking connection. Hex or square friction-fit, or press-fit axles are not acceptable. Bearings shall be Oilite® self-lubricating bronze type. Blade linkage shall be zero-maintenance, out of airstream and totally concealed within the frame. Jackshafts shall be supplied on all multiple section assemblies in order to evenly distribute torque. Blade seals shall be extruded silicone mechanically locked in extruded blade slots and shall be field replaceable. Adhesive or clip-on type blade seals are not acceptable. Jamb seals shall be compression type stainless steel.

Submitted performance data, including leakage and pressure drop, to be based on tests in accordance with AMCA Standard 500-D. Dampers must comply with the requirements of AMCA 511 Certified Ratings Program and be qualified to bear the AMCA Seal for Air Leakage and Air Performance. Damper widths from 12" to 60" (305 to 1524) shall meet leakage Class 1A criteria of maximum 3 cfm/sq. ft. (15.2 L/s/m²) at 1" w.g. (.25 kPa) and 8 cfm/sq. ft. (40.6 L/s/m²) at 4" w.g. (1 kPa). Standard of acceptance: Nailor Industries Model 2020EAF.

For CR Round Transition Option, add the following:

Damper shall be provided with a 20 ga. (1.0) galvanized steel casing for sizes up to 36" (914) dia., 18 ga. (1.31) for larger sizes, complete with round collar on both sides. Casing shall be welded and caulked against leakage. Standard of acceptance: Nailor Industries Model 2010EAF (parallel blade) or Model 2020EAF (opposed blade).