

- VEE BLADE
- STANDARD PERFORMANCE
- UNSEALED
- GALVANIZED STEEL

MODELS:

- 1012 PARALLEL BLADE**
- 1022 OPPOSED BLADE**

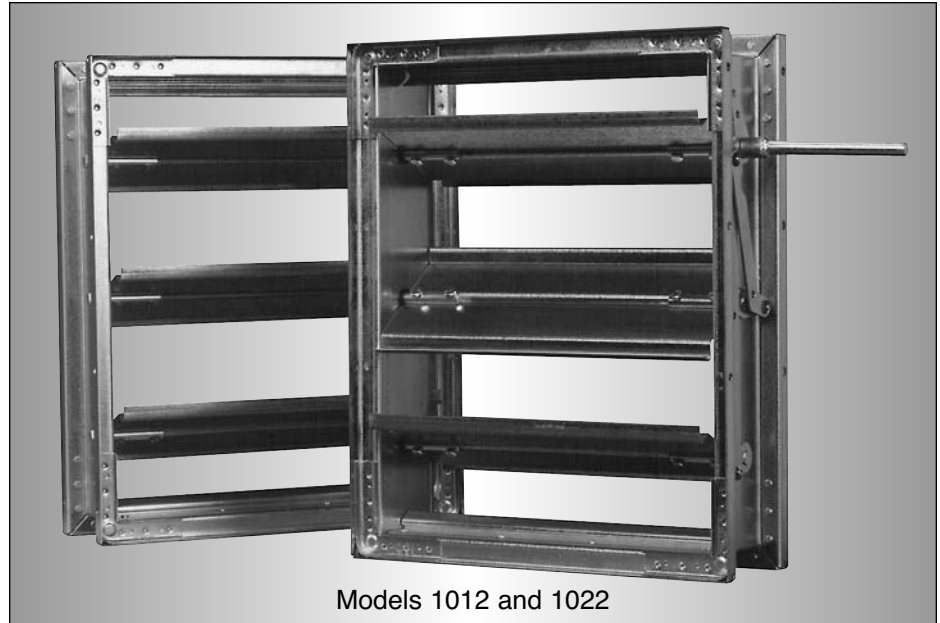

Models 1012 and 1022

The 1012/1022 Series are Nailor's most widely used unsealed dampers and are the standard choice for use in the majority of low to medium pressure and velocity commercial HVAC systems. They are low cost, high quality dampers that meet or exceed the majority of standard specification requirements. The design features include a sturdy hat channel frame with die-formed corner gussets for reinforcement and structural strength equivalent to 13 gauge channel type frames, a triple-vee blade design that maximizes strength and zero maintenance concealed linkage (out of the air stream) for reduced pressure drop and air turbulence.

B CONTROL DAMPERS

STANDARD CONSTRUCTION:

- FRAME:** 5" x 7/8" x 16 ga. (127 x 22 x 1.6) galvanized steel hat channel with die-formed corner gussets. Low profile (flat top and bottom) on dampers 10" (254) high and under.
- BLADES:** 6" (152) wide on 5 1/2" (140) centers. 16 ga. (1.6) galvanized steel triple-vee design. Parallel or opposed action.
- LINKAGE:** Concealed type totally enclosed within the frame and out of the airstream. Plated steel.
- BEARINGS:** 1/2" (13) dia. Celcon®.
- AXLES:** 1/2" (13) dia. plated steel double bolted to blades.
- DRIVE SHAFT:** 6" (152) long x 1/2" (13) dia. rigid shaft; or optional lock-on shaft with outboard support bracket (standard in Canada), on all single section dampers. A 1/2" (13) or 1" (25) dia. factory installed jackshaft is standard on all multiple section dampers.
- MINIMUM SIZE:** Single blade (parallel): 6" x 4" (152 x 102).
Two blades (parallel or opposed): 6" x 10" (152 x 254).
- MAXIMUM SIZE:** Single section: 48" x 72" (1220 x 1829).
Multiple section assembly - unlimited.

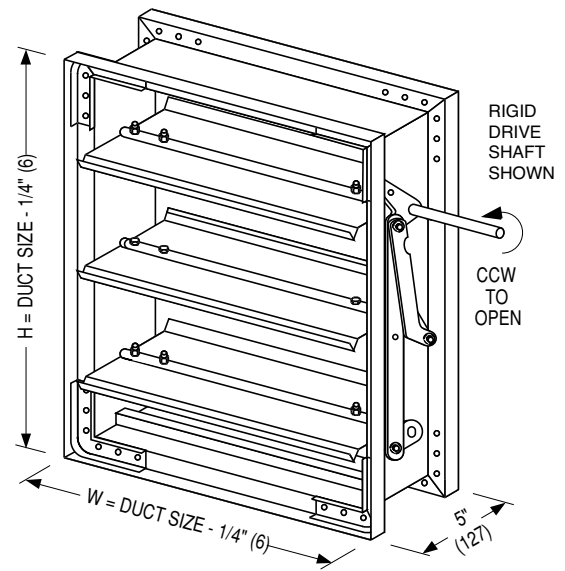

MODEL 1012
PARALLEL BLADE

MODEL 1022
OPPOSED BLADE

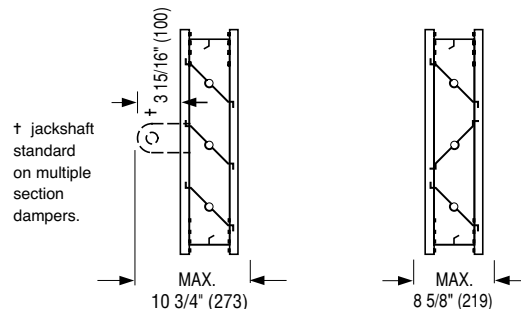

MODELS: 1012/1022

PERFORMANCE DATA:

PRESSURE DROP (damper fully open)

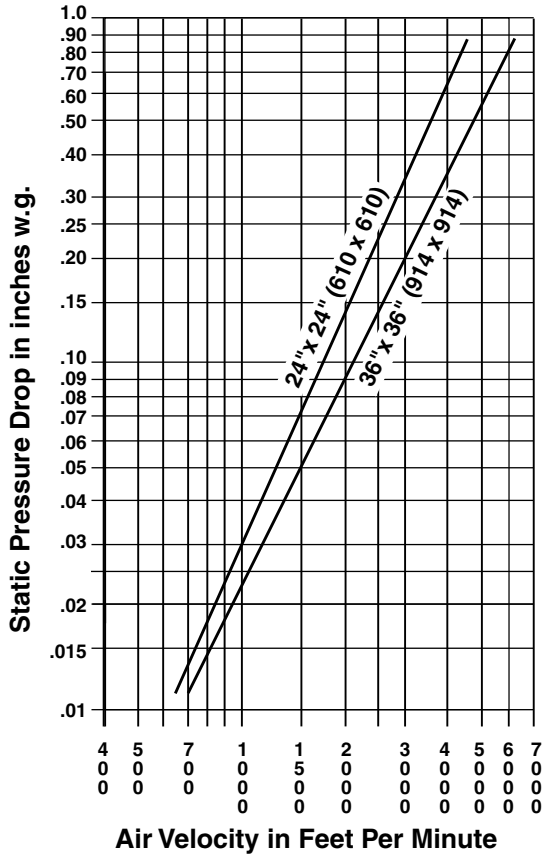

Tested per AMCA standard 500-D, Fig. 5.3.

LEAKAGE (damper fully closed w/o seals)

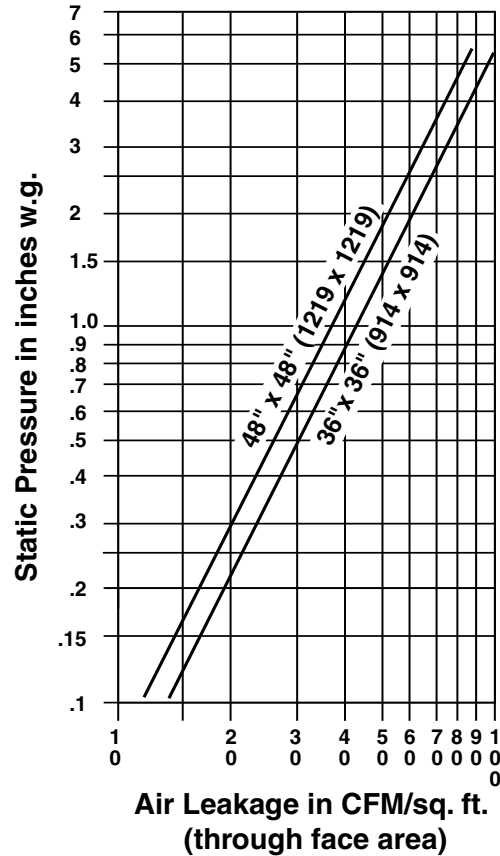

Tested per AMCA standard 500-D, Fig. 5.5.

CONTROL DAMPERS B

PRESSURE DROP (in. w.g.)

DAMPER SIZE	APPROACH VELOCITY (FPM)			
	750	1000	1500	2000
24" x 24" (610 x 610)	.016	.030	.07	.14
36" x 36" (914 x 914)	.013	.023	.05	.09
48" x 48" (1219 x 1219)	.010	.020	.03	.07

Tested per AMCA standard 500-D, Fig. 5.3.

DYNAMIC LIMITATIONS/LEAKAGE

DAMPER WIDTH	MAXIMUM SYSTEM PRESSURE	MAXIMUM SYSTEM VELOCITY	LEAKAGE *			
			W/O SEALS		W/SEALS	
			% OF MAX. FLOW	CFM/ SQ. FT.	% OF MAX. FLOW	CFM/ SQ. FT.
48" (1219)	2.5" w.g.	2000 FPM	1.90	38	0.48	9.5
36" (914)	3.0" w.g.	2000 FPM	2.15	43	0.54	10.8
24" (610)	4.0" w.g.	2000 FPM	2.35	47	0.57	11.3
12" (305)	5.0" w.g.	2000 FPM	3.10	62	0.80	16.0

* Leakage information is based upon a pressure differential of 1" w.g. tested per AMCA standard 500-D, Fig. 5.5.

Temperature Range: -50°F to 180°F (-45°C to 82°C)

MODELS: 1012/1022

AVAILABLE OPTIONS/ACCESSORIES:

The following construction options and accessories are available on Models 1012/1022. See page B55 for further description of options/accessories.

	CODE	DESCRIPTION
MATERIAL:	304 ALS	Stainless Steel Construction Aluminum Construction With Stainless Steel Hardware
FRAME:	FF FR FD	Front Flange Rear Flange Double Flange
FRAME GAUGE:	14G 13G 12G	14 Gauge 13 Gauge 12 Gauge
BLADE LINKAGE STYLE:	LF	Face Linkage
BEARINGS:	BO BS BT	Oilite® Bronze Bearings Stainless Steel Bearings Thrust Bearings
BLADE SEAL:	BSP	Polyurethane Foam Blade Seals
JAMB SEAL:	JSM	Compression Type Cambered Metal
ROUND/OVAL TRANSITION:	CR CO	Transition Casing for Round Duct Transition Casing for Oval Duct
OPERATOR ACCESSORIES:	HLQ PCE PCI FMO FMI JK5 JK1 VCK	Hand Locking Quadrant External Chain Operator Internal Chain Operator Factory Mounted Actuator-Outside w/side plate Factory Mounted Actuator-Internal w/jackshaft 1/2" (13) Dia. Jackshafting for Single Section 1" (25) Dia. Jackshafting for Single Section Vertical Interconnection Kit

B

CONTROL DAMPERS

At Nailor Industries, we take pride in our flexibility to meet the needs of your specific applications. The options listed above provide a variety of commonly used modifications to satisfy the majority of today's diverse requirements. Should your application require a more unique configuration, please consult your authorized Nailor Representative or the Nailor Industries office nearest you for assistance.

HOW TO SPECIFY OR TO ORDER

MODELS: 1012/1022

HOW TO ORDER:

Standard construction is shown in highlighted box. Option codes are listed below. See previous page for description of options.

MODEL	SIZE (W X H)	MATERIAL	FRAME TYPE	FRAME GAUGE	BLADE LINKAGE STYLE	DRIVE LOCATION	BEARINGS	BLADE SEAL	JAMB SEAL	ROUND/OVAL TRANSITION	OPERATOR ACCESSORIES
1012	ie: 48 x 24	GLV	HC	16G	LC	DR/DL	BC	-	-	-	-
1022		304 ALS	FF FR FD	14G 13G 12G	LF		BO BS BT	BSP	JSM	CR CO	HLQ FMO FMI PCE PCI JK5 JK1 VCK

- Notes:
1. 1/2" (13) or 1" (25) dia. jackshafting is standard on all multiple section wide units.
 2. If Pull Chain Operator option is selected, please specify length of chain required.
 3. If Option CR Round Transition casing (or CO) is selected please order by duct size diameter ie: 36"ø.

SUGGESTED SPECIFICATION:

Provide and install, as shown on plans and/or schedules, control dampers meeting or exceeding the following criteria: Frame shall be constructed of 16 ga. (1.6) galvanized steel hat channel with mitered corners and die-formed corner gussets for rigidity and structural strength equivalent to 13 ga. (2.4) channel type frames. Blade shall be of triple-vee design, 16 ga. (1.6) galvanized steel, on maximum 6" (152) centers, in parallel or opposed (please select) configuration. Blade axles shall be 1/2" (13) dia. plated steel, double thru-bolted to blade at each end. Hex or square friction-fit, or press-fit axles are not acceptable. Bearings shall be Celcon® molded synthetic type. Blade linkage shall be zero-maintenance, out of airstream and totally concealed within the frame. Jackshafts shall be supplied on all multiple section wide assemblies in order to evenly distribute torque. Standard of acceptance: Nailor Industries Model 1012 (parallel blade) or Model 1022 (opposed blade).

For CR Round Transition Option, add the following:

Damper shall be provided with a 20 ga. (1.0) galvanized steel casing for sizes up to 36" (914) dia., 18 ga. (1.31) for larger sizes, complete with round collar on both sides. Casing shall be welded and caulked against leakage. Standard of acceptance: Nailor Industries Model 1012CR (parallel blade) or Model 1022CR (opposed blade).