

- CAST OR EXTRUDED ALUMINUM
- HEAVY DUTY CONSTRUCTION
- FOR NEW CONSTRUCTION OR RENOVATIONS

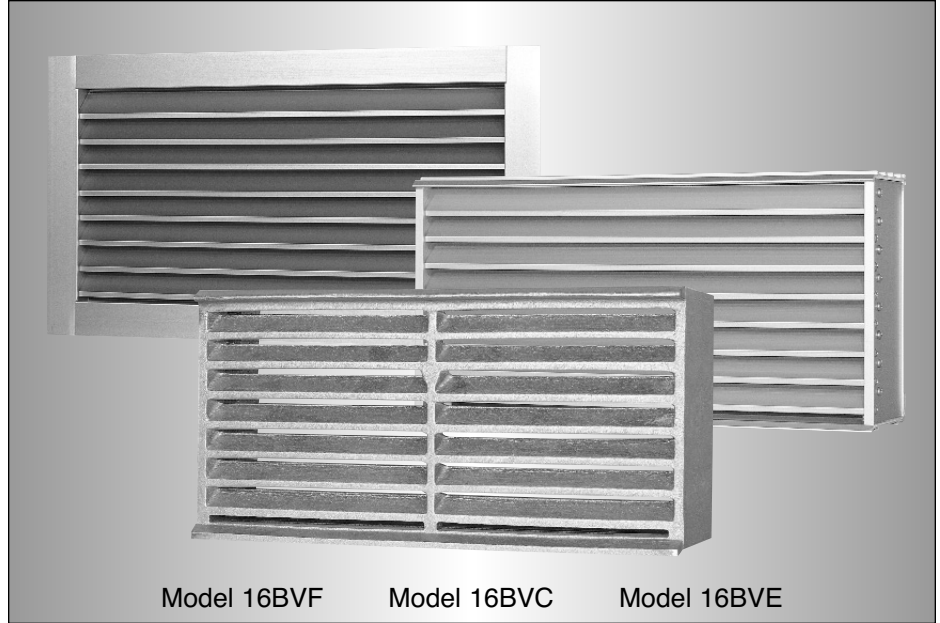

**A**

**MODELS:**

**16BVC CAST ALUMINUM**

**16BVE EXTRUDED ALUMINUM**

**16BVF EXTRUDED ALUMINUM WITH FLANGE**

Nailor 16BV Series Brick Vents provide a permanent, secure means of ventilating foundations, crawl spaces and other utility areas. All models incorporate a rear water stop and full width weepage openings for minimal water penetration during severe weather. Rugged cast or extruded aluminum construction resists potential damage due to vandalism, allowing for installation in accessible exterior areas. Standard insect screen prevents unwanted pests from entering through the vent. All models are available with an optional damper for volume control and an extended sleeve suitable for duct connection if desired.

**MODEL 16BVC**

Model 16BVC features corrosion resistant cast aluminum construction that is suitable for load bearing applications, ideal for new construction. Deep louvered blades exhibit a minimum 39% free area and provide for minimal through-viewing. A rear water stop minimizes water penetration, and top and bottom drips prevent water from staining brick.

**MODEL 16BVC STANDARD CONSTRUCTION:**

<b>FRAME:</b>	4" (102) deep, #319 cast aluminum, minimum .125" (3) thickness.
<b>BLADES:</b>	#319 cast aluminum, minimum .125" (3) thickness, with cast face mullions on 8" (203) centers.
<b>SCREEN:</b>	7 x 7 aluminum mesh insect screen.
<b>FINISH:</b>	Mill. Optional finishes are available.
<b>STD. SIZES:</b>	Width x Height
	8" x 2 1/4" (203 x 57)
	8 1/4" x 4 15/16" (210 x 125)
	8" x 7 7/8" (203 x 200)
	12" x 2 3/4" (305 x 70)
	12" x 3 1/2" (305 x 89)
	12" x 5" (305 x 127)
	12" x 7 3/4" (305 x 197)
	16 1/2" x 2 3/8" (419 x 60)
	16" x 4" (406 x 102)
	16" x 4 15/16" (406 x 125)
	16" x 6" (406 x 152)
	16" x 7 3/4" (406 x 197)

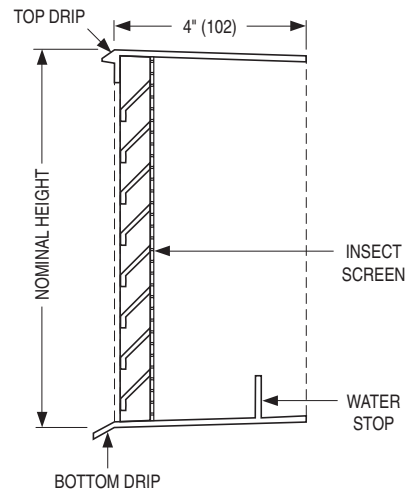

**MODEL 16BVC**

## MODEL 16BVE

Model 16BVE features corrosion resistant extruded aluminum construction with top and bottom mortar ribs, ideal for new construction. Overlapping blades with storm lip exhibit a 35% free area and, combined with a rear frame water stop, minimize water penetration. Integral top and bottom drips prevent water from staining brick.

### MODEL 16BVE STANDARD CONSTRUCTION:

- FRAME:** 4" (102) deep, Type 6063-T5 extruded aluminum, .125" (3.18) nominal wall thickness. Integral top and bottom mortar ribs.
  - BLADES:** 1" (25) deep on 1" (25) centers, Type 6063-T5 extruded aluminum, .125" (3.18) nominal wall thickness, fixed at 45 degrees, with integral storm lip.
  - SCREEN:** 18 x 14 mesh aluminum insect screen.
  - FINISH:** 204-R1 clear anodized finish. Optional finishes are available.
  - STD. SIZES:** See below. Non-standard sizes are also available.
- NOTE: For Model 16BVE, **heights** shown below do not include top and bottom mortar ribs (add 1/4" (6)).

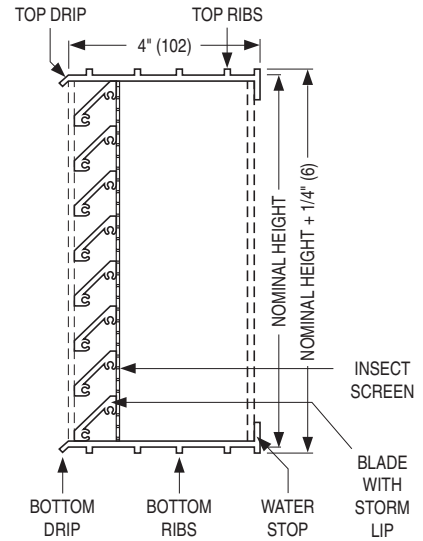

MODEL 16BVE

## MODEL 16BVF

Model 16BVF features corrosion resistant extruded aluminum construction with a flanged frame that is ideal for use in renovations or existing openings. The 1" (25) flange provides an attractive finished appearance that conceals any rough edges in the opening. Overlapping blades with storm lip exhibit a 35% free area and, combined with a rear frame water stop, minimize water penetration.

### MODEL 16BVF STANDARD CONSTRUCTION:

- FRAME:** 1 1/4" (32) deep, with integral 1" (25) flange, Type 6063-T5 extruded aluminum, .125" (3.18) nominal wall thickness.
  - BLADES:** 1" (25) deep on 1" (25) centers, Type 6063-T5 extruded aluminum, .125" (3.18) nominal wall thickness, fixed at 45 degrees, with integral storm lip.
  - SCREEN:** 18 x 14 mesh aluminum insect screen.
  - FINISH:** 204-R1 clear anodized finish. Optional finishes are available.
  - STD. SIZES:** See below. Non-standard sizes are also available.
- NOTE: For Model 16BVF, **widths** shown below do not include blade fasteners (add 1/4" (6)).

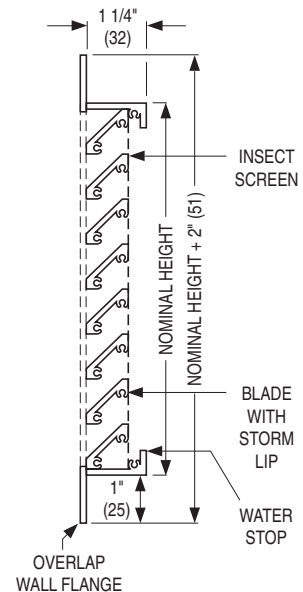

MODEL 16BVF

### MODELS 16BVE & 16BVF STANDARD SIZES (Width x Height):

8 1/8" x 2 3/8" (206 x 60)	12" x 7 3/4" (305 x 197)	16 1/2" x 2 3/8" (419 x 60)	24" x 4 3/4" (610 x 121)
8 1/8" x 4 3/4" (206 x 121)	12" x 11 3/4" (305 x 298)	16 1/2" x 4 3/4" (419 x 121)	24" x 7 3/4" (610 x 197)
8 1/8" x 7 3/4" (206 x 197)	15 5/8" x 7 3/4" (397 x 197)	16 1/2" x 7 3/4" (419 x 197)	32" x 7 3/4" (813 x 197)
12" x 4 3/4" (305 x 121)	15 5/8" x 15 3/4" (397 x 400)	16 1/2" x 15 3/4" (419 x 400)	48" x 7 3/4" (1219 x 197)